

THE EMERGENCE OF NOVEL STRAINS AND EVOLUTION OF CANINE PARVOVIRUS
2 IN THE UNITED STATES

by

CHARLES M. HONG

(Under the Direction of Jeremiah T. Saliki)

ABSTRACT

Canine parvovirus type-2 (CPV-2) is a major canine pathogen that is found all over the world. It is a non-enveloped single-stranded DNA virus approximately 26 nm in size. This virus was first reported in 1978 and has evolved with its canine host over the course of thirty years. Canine parvovirus is an important veterinary pathogen that typically affects puppies and causes hemorrhagic diarrhea, vomiting, loss of appetite, lethargy, and death. New variants of CPV-2 can now be found circulating in the United States that have previously not been described. The emergence of new variants provides evidence of Canine parvovirus evolution in the United States.

INDEX WORDS: Dog; Canine parvovirus type 2; Parvovirus; CPV-2c; Canine pathogen; Genotyping; Mutants

THE EMERGENCE OF NOVEL STRAINS AND EVOLUTION OF CANINE PARVOVIRUS
2 IN THE UNITED STATES

by

CHARLES M. HONG

BS, Virginia Polytechnic Institute and State University, 2006

A Thesis Submitted to the Graduate Faculty of The University of Georgia in Partial Fulfillment
of the Requirements for the Degree

MASTER OF SCIENCE

ATHENS, GEORGIA

2008

© 2008

Charles M. Hong

All Rights Reserved

THE EMERGENCE OF NOVEL STRAINS AND EVOLUTION OF CANINE PARVOVIRUS
2 IN THE UNITED STATES

by

CHARLES M. HONG

Major Professor: Jeremiah T. Saliki

Committee: Susan Sanchez
Zhen Fu

Electronic Version Approved:

Maureen Grasso
Dean of the Graduate School
The University of Georgia
December 2008

DEDICATION

I dedicate this document to my wonderful parents who have supported me throughout my life and encouraged me to do my best in life. Thank you for always being there for me.

ACKNOWLEDGEMENTS

Before I begin there are many people I must thank for the opportunity to come and learn at the University of Georgia. First I would like to thank my primary advisor and mentor Dr. Jeremiah Saliki for his time, his patience, and diligence in guiding me along to this point in time. I truly appreciate what he has taught me over the past couple of years in the fields of diagnostic research and virology in addition to providing the tools and environment to properly conduct my research. I now greatly appreciate all the hard work that must go into research in order to better the lives of all living beings, so for that I cannot thank Dr. Saliki enough.

I would also like to go on and thank my other committee members Dr. Susan Sanchez and Dr. Zhen Fu. Dr. Sanchez also played a vital role in providing the tools for research and guiding me along the process to properly conduct research. I appreciate her time and improving my knowledge in other aspects in infectious diseases. I would like to thank Dr. Fu for teaching me so much about various viruses.

I would especially like to thank Merial for funding. I must thank Dr. Camila Pardo and Dr. Patrick Tanner for providing samples for testing. Without them my research on canine parvovirus would not have been possible.

In addition I must thank the Department of Infectious Diseases here at Georgia for allowing me the opportunity to learn and grow. I would particularly like to thank Dr. Fred Quinn, Dr. Lilliana Jaso-Friedmann, Dr. Ralph Tripp, Dr. Mark Tompkins, Dr. Jeff Hogan, and Dr. Peterson. I must also thank all of the Athens Veterinary Diagnostic Laboratory staff for providing a safe and friendly environment to learn and conduct research. Of these individuals I

would like to acknowledge and thank Dr. Pam Currin, Rachel Steffens, Terry Bennett, Ingrid Fernandez, Holly Musgrove, and Nate Chenoweth.

In addition I must thank Dr. Colin Parrish and Karin Hoelzer from the University of Cornell and the James Baker Institute for helping me sequence and analyze the Canine parvovirus 2c isolates I have been working on. I greatly appreciate their time and kindness in aiding me in my project.

Others I would like to thank are my peers, my friends, and my family for support outside of research and school. I truly appreciate having them in my lives and am very grateful for having them in my life.

TABLE OF CONTENTS

	Page
ACKNOWLEDGEMENTS	v
LIST OF TABLESx
LIST OF FIGURESxi
CHAPTER	
1 INTRODUCTION AND LITERATURE REVIEW	1
Introduction and Brief History	1
Taxonomy and Nomenclature	2
Disease Caused by Canine parvovirus	2
Structure and Genomic Organization	4
Replication.....	5
Vaccination and Diagnosis.....	6
Evolution of CPV-2.....	8
Research Goal and Hypotheses	9
2 OCCURRENCE OF CANINE PARVOVIRUS TYPE-2C IN THE UNITED STATES	10
Abstract	12
Introduction	13
Materials and Methods	14
Results	16
Discussion	19

	Acknowledgements	23
	Sources and Manufacturers	23
3	EVOLUTION OF CPV IN THE UNITED STATES: GENETIC ANALYSIS OF CANINE PARVOVIRUS 2C ISOLATES.....	24
	Introduction	24
	Materials and Methods	25
	Cells and Virus Isolation	26
	Detection and Titration of Viruses	26
	Characterization of Virus Isolates by PCR and Sequencing	27
	Serial Passaging of Virus Isolates	28
	Complete Genomic Sequencing of Three Isolates	28
	Results.....	29
	Results of Virus Isolation and Serial Passaging.....	31
	Analysis of Sequences.....	32
	Canine Parvovirus Passaging	33
	Discussion	33
4	SUMMARY OF FINDINGS AND OVERALL CONCLUSIONS.....	35
	Detection of CPV-2	35
	Canine Parvovirus Attenuation	35
	“US-like” CPV-2c	36
	Novel Strains and Evolution of CPV-2	36
	Concluding Remarks	36
	REFERENCES	38

APPENDIX.....	43
A PERMISSION.....	43

LIST OF TABLES

	Page
Table 1.1: Antigenic Differences in CPV-2 variants	9
Table 2.1: Results of real-time PCR testing and subtyping of CPV isolates	17
Table 2.2: Primers and probes used in this study.....	22
Table 3.1: Results of PCR testing and subtyping of CPV-2 isolates from all tested states	31

LIST OF FIGURES

	Page
Figure 1.1: Genomic organization	5
Figure 2.1: Nucleotide alignment of a VP2 fragment of American CPV-2c strains	18
Figure 3.1: Distribution of CPV-2 and CPV-2c.....	30
Figure 3.2: Sequence comparison at VP2 antigenic site.....	32

CHAPTER 1

INTRODUCTION AND LITERATURE REVIEW

Introduction and Brief History

Canine parvovirus type-2 (CPV-2) has been and continues to be a major canine pathogen around the world. CPV-2 is a small virus of approximately 26 nm in size. Its genome consists of single-stranded non-enveloped DNA of negative polarity. CPV-2 is a member of the feline parvovirus subgroup of the autonomous parvoviruses. Autonomous parvoviruses do not depend on other viruses to aid in replication. Since parvoviruses can only grow in S phase, some parvoviruses, called dependo parvoviruses rely on another virus to allow the virus to replicate. An example of this is Adeno-associated virus (AAV) which needs an adenovirus for AAV to grow. CPV-2 is ubiquitous, extremely stable outside of the host, and continues to evolve. Although vaccines are currently available, the virus is still highly prevalent around not only the United States, but also all over the world.

Canine parvovirus type 2 (CPV-2) is believed to have evolved from Feline panleukopenia virus (FPV), which is a long-established virus of cats in the late 1970s. The new virus was called CPV-2 to distinguish it from CPV, the minute virus of canines. The virus was first reported in 1978, and by 1980, there was already a new variant, CPV-2a. Four years later, CPV-2b arose and it was clear that canine parvovirus was evolving. By the mid-1980s, the two variants, CPV-2a and CPV-2b, had completely replaced the original CPV-2 and occur worldwide in various proportions. In 2001, a new variant, CPV-2c was reported in Italy (Buonavoglia et al., 2001). This suggests that the virus is continuously evolving. The implications of canine parvovirus evolution are great as it may affect vaccine efficacy and proper diagnosis of parvoviral disease.

Even though the two most common strains in circulation are CPV-2a and CPV-2b (Truyen et al., 1996), the recent emergence of CPV-2c warrants attention. This strain has already been reported in Asia, Europe, and South America. It is important to monitor the progression and evolution of canine parvovirus.

Taxonomy and Nomenclature

Canine parvovirus type-2 belongs to the genus *Parvovirus* in the family *Parvoviridae*, which consists of single-stranded DNA viruses. Canine parvovirus is believed to have evolved from a close relative Feline panleukopenia virus (FPV; Truyen et al., 1995). All parvoviruses that infect and cause disease in carnivores, with the exception of a few such as Aleutian Mink Disease and Canine parvovirus type-1/minute virus of canines (MVC), are about 99% homologous in genomic sequence and are closely related antigenically (Carmichael, 2005). CPV-2 is interesting in the fact that it is able to extend its host range compared to other autonomous parvoviruses such as FPV. Canine parvovirus is over 98% similar in DNA sequence compared to not only Feline panleukopenia virus, but also compared to mink enteritis virus (MEV) and raccoon parvovirus (RPV; Chang et al., 1992). Feline panleukopenia virus and mink enteritis virus have a pH dependence of hemagglutination (HA) while CPV-2 is able to hemagglutinate at pH values between 6.0 and 8.0 (Chang et al., 1992).

Disease Caused by Canine parvovirus

Canine parvovirus-2 is an autonomous parvovirus that spreads via the fecal-oral route. The virus is difficult to control because of its ability to persist in various environments such as soil, clothes, laboratory equipment, hair, and crates, among others for up to one year outside the host. It is no surprise that from the time the virus first appeared it spread throughout the world in just two years (Carmichael, 2005). The virus is able to live outside the host, even when exposed

to UV light and other harsh conditions. The virus affects domestic canines, and also domestic felines, coyotes, foxes, wolves, ferrets, mink, and raccoons. Canine parvovirus is typically associated with the gastrointestinal (GI) tract and the myocardium. There is variation in response between animals ranging from inapparent to acute infections. Most dogs exhibit inapparent infections; the severity usually depends on the animal's age, stress level, breed, and immune status. The most severe cases are seen in puppies that are less than 12 weeks that not only lack protective immunity against disease, but also have a large number of growing and dividing cells. Since, canine parvovirus can only infect and replicate in actively dividing cells, younger growing puppies become ideal hosts for this pathogen (Greene, 1998). Puppies are also not fully protected by the maternal antibodies they receive while nursing. This phenomenon is referred to as the window of susceptibility in which there is a period of time where maternal antibodies and vaccines are not enough to protect the animal from canine parvovirus (Larson and Schultz, 1997).

Following exposure to the virus, the incubation period for CPV-2 is typically between 7–14 days, but can be as short as 4 days. Disease can also be spread by owners, handlers, asymptomatic animals, contaminated areas/items, or unsanitary conditions. Typical symptoms exhibited by dogs infected with CPV-2 are vomiting, hemorrhagic diarrhea, lethargy, and loss of appetite. Secondary infections can be common in canine parvovirus-infected animals. This can exacerbate the infection, causing the animal to become very ill and eventually succumb to the virus/secondary infection. Typical secondary infections include, but are not limited to such bacterial infections as *Clostridium perfringens*, *Campylobacter* spp., and *Salmonella* spp (Greene, 1998). Although CPV-2 has the ability to infect any domestic breed of domestic canines, certain breeds appear to be more susceptible to the virus. These breeds include

Rottweilers, Doberman pinschers, Labrador retrievers, American Staffordshire terriers, German Shepherds, and Alaskan sled dogs (Houston et al., 1996).

Structure and Genomic Organization

The genome of CPV-2 is about 5.3 Kb in size and encodes two nonstructural proteins (NS1 and NS2) and two structural proteins (VP1 and VP2). The VP1 and VP2 proteins, which are translated from alternatively spliced mRNA, make up the capsid of CPV-2. Together they form a 26 nm diameter icosahedron comprising 60 copies of the combination of the two capsid proteins (Cotmore, 1987). The VP2 structural protein is the major component of the capsid and amino acid changes in this structural protein result in antigenic changes (Parrish et al., 1985; Parrish and Carmichael, 1986). VP2 is a determinant of host immune response and host range because it contains the major antigenic sites (Parrish et al., 1991). The antigenic sites on VP2 are used to distinguish variant strains of CPV-2. There are two major open reading frames (ORFs) with the 3' half of the genome encoding for nonstructural proteins and the 5' half encoding for structural proteins (Reed et al., 1988). The nonstructural and structural genes are initiated by separate promoters and the mRNAs of both structural and nonstructural proteins contain coterminal poly-A tails and are spliced for protein synthesis (Reed et al., 1988).

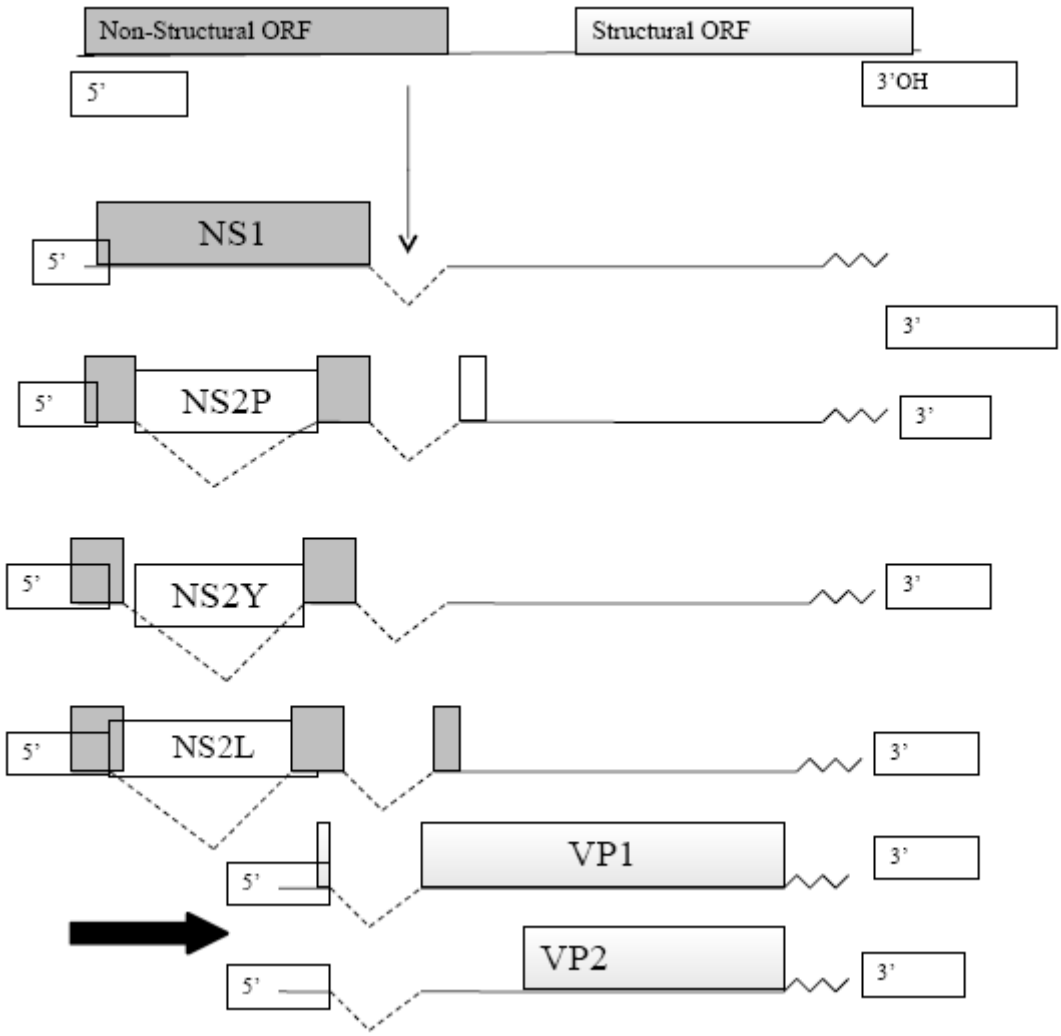

Figure 1.1: Genomic organization (Adapted from Reed et al., 1988): Displays the genomic organization of the major proteins produced from mRNA. The NS1, NS2, VP1, and VP2 proteins are shown above.

Replication

Like all viruses, canine parvovirus must be able to enter into host cells in order to replicate. Canine parvovirus can replicate in both canine and feline cells in culture while feline panleukopenia virus (FPV) can only replicate in feline cells (Truyen et al., 1992). However, with a few point mutations FPV can acquire the ability to replicate in canine cells (Fields et al., 2007).

CPV-2 must first be able to bind to specific receptors in order to begin its life cycle. It is believed that the emergence of canine parvovirus from FPV was due to FPV's ability to bind to canine transferrin receptors. The canine transferrin receptors are type II membrane proteins expressed on the cell surface as a homodimer. These receptors are located on canine cells and expressed at high densities on actively dividing cells (Truyen, 2006). CPV-2 capsids are also able to bind to sialic acids and erythrocyte receptors (Tresnan et al., 1995). The VP1 and VP2 proteins in the capsid of the virus are important for this initial process in replication due to their antigenic sites. New variants of canine parvovirus such as CPV-2a and CPV-2b were selected as a result of their improved receptor binding (Hueffer and Parrish, 2003). The interaction between the capsid and the host transferrin receptors is critical to infection (Palermo et al., 2003). Transferrin is a type II membrane protein expressed on the cell surface as a homodimer. CPV-2 also requires cellular factors expressed during S phase and since it cannot induce S phase, CPV-2 can only grow in mitotically active cells (Basak and Compans, 1989). Upon entry into susceptible host cells, CPV-2 is transported to the nucleus where the viral genome replicates. Once CPV-2 is inside the nucleus of susceptible host cells it hijacks cellular machinery in order to replicate. Canine parvovirus typically begins replication in the lymphoid tissue of the oropharynx, mesenteric lymph nodes, and thymus. The virus then disseminates to the intestinal crypts of the small intestine via viremia.

Vaccination and Diagnosis

Shortly after its emergence, vaccines were quickly made in effort to combat the spread of CPV-2. Thirty years have passed and much progress has been made concerning vaccines. Some of the earliest vaccines against CPV-2 were inactivated vaccines that proved to be ineffective just like the live attenuated FPV vaccine. In 1980, there was an outbreak involving vaccinated and

unvaccinated dogs succumbing to a variant, CPV-2a. CPV-2a exhibited acute, rapidly progressing disease in animals with extreme hemorrhagic diarrhea when compared to CPV-2. The antigenic changes accounted for increases in pathogenicity, viral growth, and host range (ability to infect cats) (Ikeda et al., 2000). It has been reported that CPV-2a and CPV-2b have now completely replaced CPV-2 in the domestic canine population (Pratelli et al., 2001). However, many of the vaccines currently available are made using the original CPV-2. And although, vaccines made from CPV-2 have been shown to protect against all antigenic types of Canine parvovirus (CPV-2a, CPV-2b, CPV-2c) there are still many clinical cases of CPV-2 in both cats and dogs (Truyen, 2006). Thus, there may be a need for using a current circulating CPV-2 variant to provide better protection for dogs (Truyen, 2006). Inactivated vaccines have only been able to provide short-term immunity to infection lasting months, as opposed to modified live vaccines, which have been shown to provide immunity for 2–3 years (Pratelli et al., 2001). A major issue in vaccination whether inactivated or modified live are maternal antibodies from the colostrum of the bitch interfering with the vaccines (Pollock and Carmichael, 1982). Canine parvovirus infects young animals when passively acquired maternal antibodies in the first weeks of life are waning (Truyen, 2006). Antigenic differences between the various antigenic types may also be clinically important when puppies with maternal antibodies at the minimum protective titer are challenged (Truyen, 2006).

With the emergence of CPV-2a and the evolution of canine parvovirus came the development of diagnostic tests to identify the virus. Currently many diagnostic techniques are available to identify CPV-2. Hemagglutination inhibition tests are also used to determine viral antibody titers using canine serum samples. Monoclonal antibodies were also developed to be used to distinguish between the two variants (Parrish and Carmichael, 1983). Monoclonal

antibodies can be used to define antigenic variation by binding to the specific antigenic sites. Another way to diagnose CPV-2 is enzyme-linked immunosorbent assay (ELISA) to detect viral antigen in animal feces. Specifically ELISA SNAP tests can be used to diagnose CPV-2 in just eight minutes. Direct fluorescent antibody (DFA) assays can also be used to identify viral antigen by using monoclonal or polyclonal antibodies tagged to fluorochromes to identify virus using fluorescent microscopy. Electron microscopy can identify virus using negative staining techniques. Polymerase chain reaction (PCR) has now become a standard for detecting CPV-2. Viral DNA is first extracted for and specific primers and probes are used to amplify pieces of CPV-2 DNA. Specifically, the VP2 gene can be used to identify the various CPV-2 subtypes by focusing on residue 426 at position 4062-4064.

Evolution of CPV-2

Between 1978 and 1982, CPV-2 was described by multiple laboratories in different countries around the world (Kelly, 1978; Appel et al., 1979; Pollock and Carmichael, 1983). Initial cases of CPV-2 involved myocarditis and bloody diarrhea and although there appear to have been thousands of cases the overall mortality was low for dogs over four months in age (Carmichael, 2005). By 1980, CPV-2 had spread worldwide. Shortly after the emergence of CPV-2, CPV-2a and CPV-2b arose and the two variant strains now have completely replaced CPV-2 in circulation around the world (Truyen et al., 1996). Around 2000, CPV-2c emerged and was first reported in Italy (Buonavoglia et al., 2001) and has been found in circulation. Between CPV-2 and CPV-2a and CPV-2 and CPV-2b there are five amino acid differences that account for antigenic differences in VP1 and VP2 genes (Table 1.1). Residues 87 and 101 are located in the VP1 capsid protein while 300, 305, 426, and 555 are located in the VP2 capsid protein. The recently emerged CPV-2c is characterized by an amino acid change in residue 426.

Table 1.1: Antigenic differences in CPV-2 variants.

CPV-2 subtype	Amino acid changes
CPV-2	Met-87, Ile-101, Ala-300, Asp-305, and Val-555
CPV-2a	Leu-87, Thr-101, Gly-300, Tyr-305, and Ile-555
CPV-2	Met-87, Ile-101, Ala-300, Asp-305, and Asn-426
CPV-2b	Leu-87, Thr-101, Gly-300, Tyr-305, and Asp-426
CPV-2c	Leu-87, Thr-101, Gly-300, Tyr-305, and Glu-426

The recent emergence of CPV-2c shows that CPV-2 is still evolving and should be continuously monitored (Nakamura et al., 2004). Like many other viruses, CPV-2 genetic evolution has given rise to new antigenic types (Parrish et al., 1991). Although CPV-2 emerged in the United States in 1978 at the same time as in many other countries, it has been six years since the new variant (CPV-2c; Buonavoglia et al., 2001) was described in Europe and Asia, but not in the United States.

Research Goal and Hypotheses

Canine parvovirus is an extremely stable virus that has the potential of affecting a wide range of host animals. In an effort to minimize spread of the virus and provide effective vaccines and diagnostic assays for infected animals, it is vital to monitor the evolution of the virus. This study is based on the following hypotheses:

- 1) The new variant, CPV-2c, which has been detected in other countries, currently circulates in the United States canine population.
- 2) Canine parvovirus type 2 continues to evolve in the United States.

CHAPTER 2

OCCURRENCE OF CANINE PARVOVIRUS TYPE-2C IN THE UNITED STATES¹

¹ Hong, C., et al. 2007. J Vet Diagn Invest 19:535–539.
Reprinted here with the permission of publisher.

CHAPTER 2

OCCURRENCE OF CANINE PARVOVIRUS TYPE-2C IN THE UNITED STATES

Charles Hong,¹ Nicola Decaro,² Costantina Desario,² Patrick Tanner,³ M. Camila Pardo,³ Susan Sanchez,¹ Canio Buonavoglia,² Jeremiah T. Saliki^{1,*}

¹ Athens Veterinary Diagnostic Laboratory, University of Georgia, Athens, GA 30602

² Department of Animal Health and Well-being, Faculty of Veterinary Medicine of Bari, Strada per Casamassima Km 3, 70010 Valenzano (Bari), Italy.

³ Biological Research and Development, Merial Limited, Athens, GA 30603

***Corresponding author:**

Jeremiah T. Saliki, Athens Veterinary Diagnostic Laboratory, University of Georgia, Athens, GA 30602. (706) 542-5568; jsaliki@uga.edu

Abstract

Canine parvovirus (CPV) type 2 (CPV-2) emerged around 1978 as a major pathogen of dogs worldwide. In the mid-1980s, the original CPV-2 had evolved and was completely replaced by 2 variants, CPV-2a and CPV-2b. In 2000, a new variant of CPV (named CPV-2c) was detected in Italy and now cocirculates with types 2a and 2b in that country. The CPV-2c has also been reported from single outbreaks in Vietnam and Spain. This study was conducted to determine if CPV-2c occurs in the United States. Thirty-three fecal samples were collected from dogs in 16 states between April 2006 and April 2007 and were tested for CPV using real-time polymerase chain reaction (PCR). Positive samples were further tested using conventional PCR and minor-groove binding TaqMan PCR assays to determine the viral type and to differentiate vaccine strains from field strains. Twenty-seven samples were positive for CPV, 7 of which were CPV-2c from 5 states: Arizona, California, Georgia, Oklahoma, and Texas. Of the 7 isolates, 4 differed from European CPV-2c isolates by 2 additional single-nucleotide mutations at positions 4076 and 4104, the latter of which produces a Thr→Ala change at residue 440 located near a major antigenic site. The coast-to-coast geographic distribution of the states in which CPV-2c was detected strongly suggests that this new CPV variant is probably widespread in the United States. The continuous evolution of CPV requires that monoclonal antibody-based and nucleic acid-based diagnostic assays should be periodically checked for sensitivity on prevalent CPV strains.

Key words: Dog; Genotyping; Parvovirus; CPV-2c; Mutants

Introduction

Canine parvovirus (CPV) emerged in the late 1970s, presumably from feline panleukopenia virus or from a wild carnivore parvovirus via genetic mutations and evolution, and it rapidly established itself as a major viral pathogen of dog populations worldwide (Kelly, 1978; Appel et al., 1979; Burtonboy et al., 1979). The new highly pathogenic virus was named CPV type 2 (CPV-2) to distinguish it from the less pathogenic and antigenically unrelated CPV type 1 or minute virus of canines (Carmichael et al., 1994). Shortly after its emergence, the original CPV-2 continued to evolve and was completely replaced by 2 variants, CPV-2a and CPV-2b, by the mid-1980s (Parrish et al., 1988; Parrish et al., 1991; Pereira et al., 2000). In the past 20 years, CPV-2a and CPV-2b have cocirculated in various proportions among dog populations worldwide (Truyen, 2006).

In 2000, a new variant of CPV (subsequently named CPV-2c) was detected in Italy (Buonavoglia et al., 2001) and is now widely distributed and cocirculating with types 2a and 2b in that country (Martella et al., 2004; Martella et al., 2005). The CPV-2c has also been reported from single outbreaks in Spain (Decaro et al., 2006) and Vietnam (Nakamura et al., 2004). This new variant is distinguishable from CPV-2a/2b by the substitution of Glu in lieu of Asn or Asp at residue 426 of the capsid protein VP2; therefore, it is also referred to as Glu-426. This substitution involves a major antigenic site (epitope A) located on the 3-fold spike of the capsid protein (Strassheim et al., 1994) and results in a change in antigenicity that has made it possible to differentiate CVP-2c from CPV-2a/2b using monoclonal antibodies (Nakamura et al., 2004).

Genetic variation in a virus can adversely affect nucleic acid–based diagnostic assays if a change occurs in the primer binding region. Monoclonal antibody–based assays may also be adversely affected if genetic variation results in a change in the antibody binding site. Similarly,

antigenic variation may negatively affect vaccine efficacy if biologically significant changes occur in major antigenic sites. For these reasons, it is important to continuously monitor the occurrence of novel genetic and antigenic types in viruses, such as CPV, that appear to continuously evolve. The objective of this work was to determine if the CPV-2c that has recently been described in Europe and Asia also occurs in the United States.

Materials and Methods

A total of 33 fecal samples from vaccinated (n = 31) or unvaccinated (n = 2) dogs were obtained by Merial Limited, to support epidemiologic surveying. The samples were collected between April 2006 and April 2007, and they originated from 16 states (Table 1). All samples were tested for CPV DNA using a previously described CPV-2 group-specific TaqMan-based real-time polymerase chain reaction (PCR) assay (Decaro et al., 2005). Samples that were positive using real-time PCR were further tested using minor groove binder (MGB) TaqMan PCR assays (Decaro et al., 2006; Decaro et al., 2006; Decaro et al., 2006) and a conventional PCR to determine the viral type. The 33 samples were also used for virus isolation.

Template DNA was extracted from 10% (wt/vol) suspensions of fecal samples in Dulbecco's minimal essential medium (DMEM) using a commercial DNA fecal extraction kit.^a Extracted DNA samples were stored at -20°C until tested. For each PCR reaction, DNA from previously typed CPV field isolates representing subtypes 2a, 2b, and 2c were included as positive controls, while a sample extracted from DMEM using the same DNA fecal extraction kit was included as a negative control.

The TaqMan and MGB probe assays were carried out in a 25- μ l reaction containing 10 μ l of template DNA or control DNA (both in duplicates), 12.5 μ l of IQ Supermix,^b 600 nM (TaqMan assay) or 900 nM (MGB probe assays) of primers, and 200 nM of probes. The thermal

cycling parameters were as follows: activation of iTaq DNA polymerase at 95°C for 10 minutes, 45 cycles of denaturation at 95°C for 30 seconds, and primer annealing/extension at 60°C for 1 minute. All reactions were conducted in an i-Cycler iQ Real-Time Detection System,^c and the data were analyzed using the software included (version 3.0).

To determine if CPV subtype 2c isolates from the United States are similar to those described in Europe, a 583-segment of the VP2 gene generated using conventional PCR was sequenced. This segment includes the sequence of the amino acid residue at position 426 that was the basis for CPV-2c being classified as a different subtype than CPV-2a and CPV-2b. Conventional PCR was performed as previously described (Buonavoglia et al., 2001; Desario et al., 2005), with minor modifications. Briefly, the reaction was carried out in a volume of 50 µl containing: 30 µl of AmpliTaq Gold Master Mix (0.05 U/µl AmpliTaq Gold DNA polymerase, GeneAmp PCR Gold Buffer [30 mM Tris/HCl, pH 8.05, 100mM KCl], 480 µM dNTP, 5 µM MgCl₂, and stabilizers),^d 5 µl of deionized water, 5 µl (1 µM) of forward primer,^d 5 µl (5 µM) of reverse primer,^e and 5 µl of template DNA. The thermal cycling conditions were as follows: activation of AmpliTaq Gold polymerase at 10 minutes at 94°C; 35 cycles of denaturation at 94°C for 30 seconds, primer annealing at 50°C for 1 minute, extension at 72°C for 1 minute, followed by a final extension at 72°C for 10 minutes and a 4°C hold. All reactions were conducted in an Eppendorf mastercycler gradient machine.^f Eight reactions were performed for each sample, and one product was resolved on a 1.5 agarose gel and stained with ethidium bromide to verify the presence of the 583-bp band. The remaining 7 amplified products from each sample were combined, and the amplicon was purified using an Ultrafree-DNA gel purification kit,^g according to the manufacturer's instructions. Sequencing of purified amplicons was carried out by a commercial facility.^h

For virus isolation, a 10% suspension of feces was prepared in DMEM supplemented with 10 mM HEPES buffer and 1 µg/ml gentamicin sulfate. This suspension was clarified by centrifugation at $800 \times g$ for 10 minutes, filtered through a 0.45-µ filter, and used to inoculate 2 cell lines: the A-72 canine kidney cells and Crandell-Reese Feline Kidney (CRFK). The inoculations were performed by adding 2 drops of inoculum onto freshly trypsinized cells seeded into 24-well plates at 1 ml/well (125,000 cells) in DMEM containing 10% fetal bovine serum. After 5 days of incubation at 37°C in 5% CO₂, the cells were trypsinized, spotted into wells of Teflon-coated glass slides, fixed for 10 minutes in 100% acetone at room temperature, and stained for CPV antigen by reacting with a fluorescein isothiocyanate–labeled polyclonal anti-CPV antibody.¹ The cells from the first passage were reseeded into 24-well plates (2 wells per inoculum) and stained after 5 days if the first passage was negative for CPV. Cultures that remained negative after the second passage were scored as negative for virus isolation.

Results

Of the 33 samples, 27 were found to be positive for CPV using real-time PCR (Table 1) lists the states of origin of the 33 samples and the MGB-PCR results for the 27 positive samples. Seven dog samples originating from 5 states were characterized as CPV-2c. The dogs were of 7 different breeds, ranged in age from 3 to 8 months, and had all received 2 or 3 doses of different types of commercially available CPV vaccines before onset of clinical signs, which included nausea, vomiting, and diarrhea. The single CPV-2a subtype and 17 of the 19 CPV-2b subtypes originated from clinically sick dogs of various breeds, ranging in age from 2 to 14 months that had received 2 to 4 doses of various commercially available CPV vaccines. Using MGB-PCR analysis (Decaro et al., 2006), 16 of the 27 CPV strains detected in this study (including the lone CPV-2a) were determined to be field strains rather than vaccine strains. The other 11 strains

were not differentiated for vaccine or field origin. However, because all of these 11 strains were either CPV-2b or 2c, they could not be of vaccine origin because vaccines containing these subtypes are not used in the United States.

Table 2.1: Results of real-time PCR testing and subtyping of CPV isolates.

State of origin	No. tested	Real-time PCR and MGB results			
		Negative	2a	2b	2c
AR	1			1	
AZ	2				2
CA	2				2
FL	1	1			
GA	12		1	10	1
IA	1			1	
KY	1			1	
MD	1	1			
MS	1			1	
NC	2	2			
NV	1	1			
OH	1			1	
OK	1				1
TN	2	1		1	
TX	3			2	1
WI	1	1		1	
Total	33	6	1	19	7

The PCR products of the 7 CPV-2c subtypes detected in this study were sequenced in the VP2 region spanning nucleotides 4002 through 4585 of the CPV genome and compared with GenBank sequences of CPV-2, CPV-2a, CPV-2b, and CPV-2c using a ClustalW-based online sequence alignment tool (<http://justbio.com/aligner/index.php>; Fig. 1). Based on the occurrence of the codon GAA at position 4062 to 4064 (encoding for glutamine at residue 426), all 7 isolates were confirmed by sequencing as CPV-2c. However, the sequence alignment also showed that 4 of the 7 U.S. CPV-2c strains differed from 3 previously described European isolates by

exhibiting 2 further mutations in the target region: G→A at nucleotide 4076, which involves the third base of codon 430 and thus does not cause a change in residue; A→G at nucleotide 4104, which affects the first nucleotide of codon 440, changing it from ACA to GCA, thus altering amino acid residue 440 from threonine to alanine (Thr→Ala). In the 2 states (Arizona and California) from which 2 CPV-2c were detected, one isolate in each case was identical to European isolates in the sequenced region, while the other exhibited the Thr→Ala mutation described in this study.

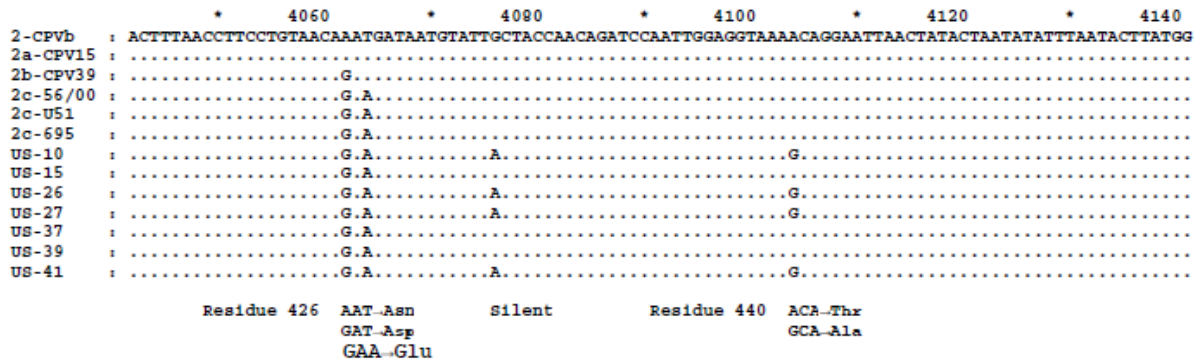

Figure 2.1: Nucleotide alignment of a VP2 fragment of American CPV-2c strains with reference strains CPV-2 CPVb (GenBank accession number M38245), CPV-2a CPV-15 (M24003), CPV-2b CPV-39 (M74849), CPV-2c 56/00 (AY380577), U51 (AY742942), and 695 (AF401519).

Only the segment exhibiting differences is shown.

Virus isolation attempts yielded only 6 CPV isolates (3 CPV-2b and 3 CPV-2c). Identical results were obtained on both cell lines used (A-72 and CRFK). The relatively low sensitivity of virus isolation compared with real-time PCR has been previously reported (Decaro et al., 2005; Desario et al., 2005) and could have been exacerbated in this study by the fact that several of the

samples had been frozen and thawed multiple times, possibly diminishing or abrogating virus viability. Nevertheless, the availability of some isolates from this study provides material for further analysis and possible future use as vaccine or challenge-strain candidates.

Discussion

The findings from this study indicate that CPV-2c is probably widely distributed in the United States, because the 7 isolates originated from geographically widely dispersed locations, and there was no evidence of prior contact between any of the dogs. It is not possible, however, to determine from the current study how long CPV-2c might have occurred in the United States. The finding of mutations in 4 of the 7 U.S. isolates that do not occur in the 3 European CPV-2c isolates from 1997–2000 might mean that the 2 groups of CPV-2c isolates evolved independently. However, antigenic analysis and further sequence comparison involving more of the genome of both groups of isolates is required before a definitive statement can be made on their evolution.

Although it is tempting to think that CPV-2c could have emerged as an escape mutant from vaccination pressure, the results of this study do not seem to support that hypothesis. Indeed, most of the isolates typed in this study (19 of 27) were CPV-2b, and they originated from dogs with a vaccination history similar to the dogs from which CPV-2c was detected. Moreover, all 27 isolates originated from different dogs, and no dogs were infected with more than one subtype. Furthermore, although complete clinical histories were not obtained for all dogs, the short time interval (2 days) from vaccination to onset of clinical signs in 2 cases indicates that some of the dogs might have been infected before vaccine administration. Moreover, 2 of the dogs infected with CPV-2b had never received a CPV vaccine. It is also noteworthy that the 7

dogs infected with CPV-2c exhibited clinical signs and outcomes that were similar to those exhibited by the dogs infected with CPV-2a and CPV-2b.

The continuous evolution of CPV strains, coupled with persistent anecdotal reports of “vaccine breaks” may have important implications for vaccine formulations. Most vaccines used worldwide are based on the original 1978 CPV-2 dog isolate cultured at the James Baker Institute for Animal Research, New York State College of Veterinary Medicine (Cornell University, Ithaca, NY). Although there is evidence to show that vaccines based on this original CPV-2 isolate are protective against CPV-2c challenge (Toulemonde CE, Brunet S, Cariou C, et al.: 2006, Management of canine parvovirus type 2 in a kennel environment. Proc Journées GTV, Dijon, France; Spibey N, Greenwood N, Tarpey I, et al.: 2006, Canine parvovirus type 2 vaccine protects dogs following challenge with a recent type 2c strain. Proc World Small Animal Veterinary Association Congress, Prague), it is nonetheless important for pharmaceutical companies to consider using current strains in vaccine formulations (Greenwood et al., 1995; Yule et al., 1997; Pratelli et al., 2001; Decaro et al., 2005; Martella et al., 2005). Such considerations recently led to the licensing of a CPV-2b–based vaccine in Europe (Martella et al., 2005).

The continuous evolution of CPV also has serious implications for diagnostic tests based on monoclonal antibodies and PCR. It has been shown that the Glu-426 change in CPV-2c results in an antigenic difference detectable by monoclonal antibodies (Nakamura et al., 2004). The Thr→Ala mutation detected in this study is located in close proximity to the Glu-426 residue in the major antigenic site (epitope A) found on the 3-fold spike of the CPV capsid protein (Strassheim et al., 1994); thus, it is possible that the Thr→Ala mutation could be antigenically significant, although this remains to be determined. Nevertheless, continuous evolution of CPV

requires that diagnostic assays based on a single detecting monoclonal antibody be evaluated periodically for their continuous sensitivity against new strains of CPV. Similarly, nucleic acid–based tests need to be evaluated continuously to ensure that mutations have not occurred in primer/probe binding regions.

Table 2.2: Primers and probes used in this study.

Assay	Primer/Probe	Sequence (5' to 3')	Amplicon size	References
Real-time PCR	Forward	AAACAGGAATTAAGTATACTAATATATTTA	93	10
	Reverse	AAATTTGACCATTTGGATAAACT		10
	Probe	FAM-TGGTCCTTTAACTGCATTAATAATGTACC-TAMRA		10
Conventional PCR	Forward	CAGGAAGATATCCAGAAGGA	583	3, 14
	Reverse	GGTGCTAGTTGATATGTAATAAACA		3, 14
CPV-2a/2b MGB	Forward	AGGAAGATATCCAGAAGGAGATTGGA	93	11
	Reverse	CCAATTGGATCTGTTGGTAGCAATACA		11
	CPV-2a probe	VIC-CTTCCTGTAACAAATGATA-MGB		11
	CPV-2b probe	FAM-CTTCCTGTAACAGATGATA-MGB		11
CPV-2b/2c MGB	Forward	GAAGATATCCAGAAGGAGATTGGATTCA	150	11
	Reverse	ATGCAGTTAAAGGACCATAAGTATTAATATATTAGTATAGTTAATTC		11
	CPV-2b probe	FAM-CCTGTAACAGATGATAAT-MGB		11
	CPV-2c probe	VIC-CCTGTAACAGAAGATAAT-MGB		11
CPV field vs. vaccine	Forward	GCAGTTAACGGAAACATGGCTTTAG	150	12
	Reverse	TCAACCAATGACCAAGGTGTTACAA		12
	Probe: CPV-2 old type	FAM-TGTGCATGAATATCAT-MGB		12
	Probe: CPV-2 variant	VIC-TTTGTGCATGAGTATCAT-MGB		12

Acknowledgements

The technical help of Nate Chenoweth is greatly appreciated. This study was funded by a grant from Merial, Inc.

Sources and Manufacturers

- a. UltraClean Fecal DNA Kit, Mo Bio Laboratories Inc., Carlsbad, CA.
- b. Bio-Rad Laboratories Srl, Milan, Italy.
- c. Bio-Rad Laboratories, Hercules, CA.
- d. AmpliTaq GOLD Master Mix, Applied Biosystems, Branchburg, NJ.
- e. Primers and probes, IDT, Coralville, IA.
- f. Mastercycler Gradient, Eppendorf, Hamburg, Germany.
- g. Ultrafree-DA, Millipore, Bedford, MA.
- h. Oklahoma Medical Research Foundation, Oklahoma City, OK.
- i. Canine parvovirus direct fluorescent antibody conjugate, American Bioresearch, Sevierville, TN.

CHAPTER 3

EVOLUTION OF CPV IN THE UNITED STATES: GENETIC ANALYSIS OF CANINE PARVOVIRUS 2C ISOLATES

Introduction

Canine parvovirus (CPV) first emerged in 1978 and has been prevalent in the canine population ever since. The virus is believed to have emerged from *Feline panleukopenia virus* (FPV) through genetic drift and evolutionary processes. The virus is an enteric virus that attacks the gastrointestinal tract of dogs and induces symptoms such as vomiting and hemorrhagic diarrhea. The virus is a major pathogen affecting not only domestic canines but also domestic felines, wolves, foxes, bush dogs, coyotes, ferrets, minks, and raccoons (Greene, 2006). The virus is disseminated via the fecal-oral route and can be picked up by an animal through feces, soil, contaminated clothes, and previously contaminated areas. The capsid of CPV consists of stable proteins, which allow the virus to withstand an array of environmental conditions such as sunlight and remain stable in the environment for over six months. CPV is an important viral pathogen because of its increased host range compared to other autonomous parvoviruses.

In the laboratory, conventional PCR is used to amplify a 583 bp product containing the major antigenic site for typing CPV isolates. The 426 residue is used to differentiate between the current identified strains. There are currently four characterized subtypes for CPV: CPV-2 (the original virus that emerged in 1980), CPV-2a, CPV-2b, and CPV-2c. CPV-2c differs from CPV-2a and CPV-2b by the occurrence of glutamic acid instead of aspartic acid in residue 426; hence the synonym Glu-426. Recently CPV-2c emerged in the United States (Hong et al., 2007; Kapil et al., 2007). The defining amino acid change is located at residue 426 of CPV-2c, which results

from a single nucleotide change at position 4062 to 4064 that changes the codon from GAT to GAA. This single nucleotide mutation distinguishes CPV-2c from CPV-2a and CPV-2b. Several isolates of CPV-2c were obtained from several states in the continental United States of America. This chapter describes the sequencing of 3 isolates from geographically distant sites to shed further light on the evolution of CPV-2 in the United States. Furthermore, the three isolates were serially passaged in cell cultures in an attempt to attenuate them for use as possible vaccine candidates. Two variants of CPV-2c have been described in the United States, one strain (“European-like”) is similar to those found in Italy, Spain, Vietnam, among other countries reporting the presence of CPV-2c. The other strain (“US-like”) contained additional mutational changes in the 430 and 440 residues. Antigenic changes allow CPV-2 to not only to increase host range both *in vivo* and *in vitro*, but also have increased affinity to canine transferrin receptors (Hueffer and Parrish, 2003).

Materials and Methods

A total of 168 samples were submitted by Merial and Athens Diagnostic Research Laboratory for testing. These samples were either of fecal or intestinal samples from domestic canines highly suspected of CPV-2 infection. The samples were determined to be CPV-2c through DNA extraction and sequence typing using conventional PCR as described in chapter 2 (Hong et al., 2007). From the CPV-2c samples, we chose 3 samples for full genomic sequencing. These three samples were chosen to represent a large geographic area of the United States and to represent the two types of CPV-2c found circulating in the United States. Immunofluorescent assay was used to determine presence of Canine parvovirus.

Cells and Virus Isolation

Two different cell lines were used for virus isolation. The first was a canine kidney cell line (A-72) and the second Crandall-Reese feline kidney cell line (CRFK). The three samples used in this study were all fecal samples that were filtered through a 0.45 µm filter and were inoculated into 24-well plates of both types of cells. Each well had 250,000 cells in 1.5 mL of either A-72 or CRFK cells.

Detection and Titration of Viruses

For virus detection, we performed fluorescent antibody testing to determine the presence of CPV-2. This was done because CPV-2 does not induce cytopathic effects (CPE) to cells. Briefly, virus inoculated wells of A-72 and CRFK were allowed to incubate for 5 days in a CO₂ incubator at 35.5°C. The cells were trypsinized with 250 µl trypsin 5 days post-infection. After allowing proper trypsinization of cells, 650 µl of DMEM with 10% fetal bovine serum was added to inactivate trypsin. The cell suspension was then centrifuged to pellet cells and resuspended in 200 µl DMEM with 10% fetal bovine serum and transferred to glass slides and allowed to incubate 1 hour in a CO₂ incubator at 35.5°C. After incubation, the cells were acetone-fixed for 10 minutes to glass slides and then 40 µl CPV DFA conjugate was added. The slides were once again allowed to incubate for 30 minutes in a CO₂ incubator at 35.5°C and then washed with saline solution for 10 minutes before viewing under fluorescent microscope. CPV-2 positive cells would exhibit intracellular staining.

The three canine parvovirus isolates were also titrated using a hemagglutination assay. Swine whole blood was obtained (Innovative Research, Novi, Michigan). Red blood cells (RBCs) were taken from the whole blood via centrifugation. The RBC-rich pellet was washed a total of five times with phosphate buffered saline (PBS). Using 96-well U-bottom plates, serial

two fold dilutions were performed using 50 μ L of each isolate in PBS. After serial dilutions, 50 μ L of 0.8% washed erythrocytes in PBS with 1% fetal bovine serum (FBS) was then added. The 96-well plates were incubated at 4°C for 4 hours and then plates were read to determine titer. In the presence of CPV-2, the well would exhibit a “lawn” of cells distributed throughout the well, while if CPV-2 was not detectable there would be a neat “button” of RBCs at the bottom of each well.

Characterization of Virus Isolates by PCR and Sequencing

For initial characterization for the CPV-2 isolates, conventional PCR was used. The PCR reaction was carried out in a volume of 50 μ L containing: 30 μ L of AmpliTaq Gold Master Mix (0.05 U/ μ L AmpliTaq Gold DNA polymerase, GeneAmp PCR Gold Buffer [30 mM Tris/HCl, pH 8.05, 100mM KCl], 480 mM dNTP, 5 mM MgCl₂, and stabilizers), 5 μ L of deionized water, 5 μ L (1 mM) of forward primer, 5 μ L (5 mM) of reverse primer, and 5 μ L of template DNA (Desario et al., 2005; Hong et al., 2007). The thermal cycling conditions were as follows: activation of AmpliTaq Gold polymerase at 10 minutes at 94°C; 35 cycles of denaturation at 94°C for 30 seconds, primer annealing at 50°C for 1 minute, extension at 72°C for 1 minute, followed by a final extension at 72°C for 10 minutes and a 4°C hold. All reactions were conducted in an Eppendorf mastercycler gradient machine. Eight reactions were performed for each sample, and one product was resolved on a 1.5% agarose gel and stained with ethidium bromide to verify the presence of the 583-bp band. The remaining 7 amplified products from each sample were combined, and the amplicon was purified using a Qiagen QIAquick purification kit (Qiagen, Valencia, CA), according to the manufacturer’s instructions. Sequencing of purified amplicons was carried out by OMRF, a commercial facility.

Serial Passaging of Virus Isolates

After initial virus isolation and detection of virus via direct fluorescent antibody assay (DFA), the supernatant of that virus was used to subsequently passage into the same cell line in which the virus was isolated. The viral supernatant of each isolate was used to inoculate a new 24 well plate of cells in effort to adapt the virus to that particular cell line. Each week, A-72 and CRFK cells are split and seeded using trypsin to break up the monolayer of cells. A-72 and CRFK cells are counted and distributed into 24-well plates for virus inoculation with viral supernatant from the previous week. The cells were inoculated immediately after being split and aliquoted into 24-well plates. The plates were then incubated for a period of 5 days in a humid CO₂ incubator at 35.5°C at 5% CO₂. DFA was used to determine successful passaging week to week via intracellular staining of viral antigen after a 5-day incubation.

Extracted DNA from the three isolates serially passaged in A-72 cells was used to perform complete genomic sequencing. The viral supernatant from the isolates passaged in A-72 cell line was used because they were able to be passaged more successfully compared to CRFK cell line.

Complete Genomic Sequencing of Three Isolates

For our complete genomic sequencing, two facilities were used. The viral supernatant from each serially passaged isolate was used to extract DNA from each of the three isolates (UGA 27, UGA 67, and UGA 90). The MoBio UltraClean DNA fecal extraction kit (MoBio, Carlsbad, CA) was used to extract the DNA. The extracted DNA for each isolate was then sent to be sequenced by SeqWright and laboratory of Dr. Parrish at the James Baker Institute for Animal Health in Cornell. Both sequencing facilities used sets of primers to “primer walk” the three isolates used to obtain full genomic sequences.

Extracted DNA of “early” passages (passage 3 for each of three isolates) and “late” passages (last available, FA positive isolate) were sequenced to determine whether any mutation arose as a result of serial passaging in A-72 cells. These changes are important since the point of serial passaging the three virus isolates is to induce novel mutations in order to attenuate the virus. Virus attenuation is vital in order to have a possible vaccine candidate to perform a challenge experiment in animals. For UGA 27, passage 43 was the last passage done. We only could successfully passage UGA 67 up to passage 10 and had trouble passaging this isolate in either cell line. UGA 90 was passaged 53 times in the A-72 cell line.

Results

Of the total of 168 samples, 39 of the samples collected were determined to be CPV-2c. Of the 39 CPV-2c isolates, we were able to virus isolate 15 of them using A-72 and CRFK cells. We were unsuccessful in serially passaging virus in CRFK after about 5 passages, while we had no trouble in A-72 cells. HA titers were also higher in A-72 cells compared CRFK cells at the same passage level. CPV 27 was only able to be passaged successfully in A-72 cells, while CPV 90 was able to be passaged in both A-72 and CRFK cell lines. Our genomic comparison compares CPV 27, CPV 67, and CPV 90 serially passaged in A-72 cells for the VP2 gene (Figure 3.2).

A)

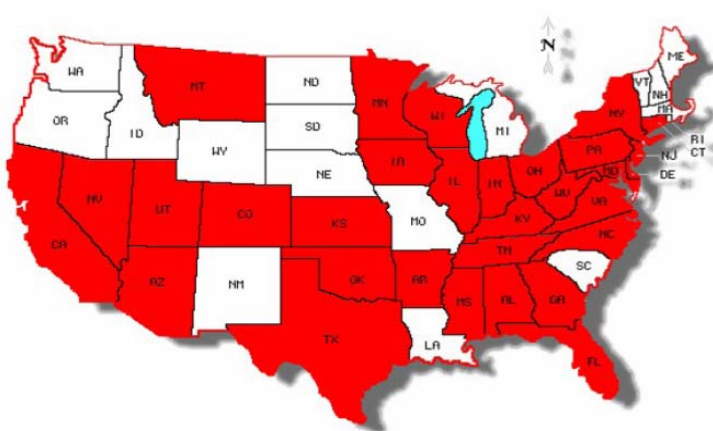

B)



Figure 3.1: Distribution of CPV-2 and CPV-2c: A) 31 states from which CPV-2 samples came from; B) 10 states CPV-2c present.

Table 3.1: Results of PCR testing and subtyping of CPV-2 isolates from all tested states

State of origin	No. tested	Real-time PCR and conventional PCR			
		Negative	2a	2b	2c
AL	3			3	
AR	1			1	
AZ	5			1	4
CA	5				5
CO	14			7	7
CT	1			1	
DE	1			1	
FL	8	1	1	5	1
GA	56	5	1	40	10
IA	1			1	
IL	2			2	
IN	10	1	1	8	
KS	2			2	
KY	2			2	
MD	1	1			
MN	1			1	
MS	6			2	4
MT	1			1	
NC	3	2		1	
NJ	1	1			
NV	1	1			
NY	1			1	
OH	2			2	
OK	2				2
PA	1	1			
TN	3	1		2	
TX	4			3	1
UT	1			1	
VA	1			1	
WI	25	1		20	4
WV	3			2	1
Total	168	15	3	111	39

Results of Virus Isolation and Serial Passaging

We found that CPV-2c grew better in the A-72 cell line as opposed to the CRFK cell line supporting previous findings (Decaro et al., 2007). A-72 is a modified canine kidney cell line and CRFK is a modified feline kidney cell line. We were unable to successfully passage UGA 67

past passage 10 in either cell line. UGA 27 was only successfully passaged in A-72 and did not grow well in CRFK cells after about 8 to 10 passages. UGA 90 grew well in both A-72 and CRFK cells throughout our passaging experiment.

Analysis of Sequences

Genomic sequencing was done for the three Canine parvovirus isolates (UGA 27, UGA 67, and UGA 90) at two different points in serial passaging. Specifically, we concentrated on the VP2 gene because of the important antigenic sites for binding to host cells. In the VP2 gene, we detected the same mutations reported in the previous chapter (Hong et al., 2007). Mutational changes between early passages and the latest passages were done to detect mutations that were a result of serial passaging in A-72 cell line. For UGA 27 we compared passage 3 and the passage 43. There is a novel mutation that occurs over the 40 passages at residue 426 that changes the Glu→Lys. For UGA 67, passage 3 and passage 10 showed no differences at the 426 site. However, for UGA 90 the “European-like” CPV-2c mutated into a “US-like” CPV-2c after 50 passages in A-72 cells.

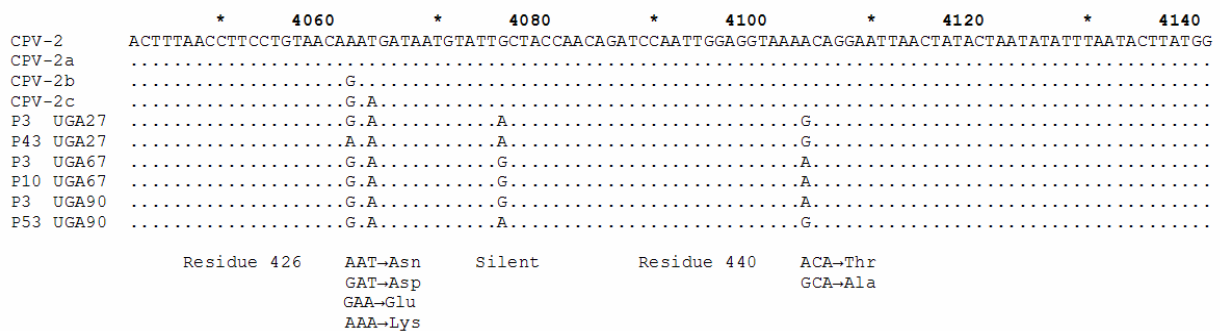

Figure 3.2: Sequence comparison at VP2 antigenic site

Canine Parvovirus Passaging

Our laboratory has been serially passaging Canine parvovirus isolates in an attempt to attenuate the virus via cell adaptation using A-72 and CRFK cell lines. We successfully serially passaged six different CPV-2c isolates. In addition to the previous three isolates, we have serially passaged three additional “US-like” CPV-2c isolates: UGA 158, UGA 164, and UGA 167. This brings the total “US-like” CPV-2c isolates to four (Including UGA 27). In addition, two “European-like” CPV-2c samples (UGA 67 and UGA 90) were serially passaged. Upon passaging these six isolates, we have noticed that we were able to passage the viral isolates up to passage 10 in both A-72 and CRFK cells. However, after passage 10, we were not able to passage the “US-like” CPV-2c variant in CRFK cells any further. The “US-like” CPV-2c variants still were able to be serially passaged after passage 10 only in A-72 cells. As apposed to the “European-like” CPV-2c variants that were able to be passaged in both cell lines.

Discussion

Two types of CPV-2c (“European-like” and “US-like”) are found circulating in the continental United States. Based on mutations seen through serially passaging CPV-2c *in vitro*, it is possible for novel variants to arise in the wild in the near future. The mutations from serially passaging in A-72 cells indicate the 426 residue site between 4062 – 4064 is a variable site for possible antigenic change. This may be a critical site for host adaptation as we see the significant mutational changes from serially passaging UGA 90. Specifically, the mutation observed in the UGA 27 isolate with the novel Glu→Lys change may be a novel variant that has not been reported and may be detected in nature as CPV-2c continues to circulate in the canine population. It is evident that CPV-2c can be modified *in vitro* using A-72 and CRFK cell lines. CPV-2c may be able to grow better in A-72 cells versus CRFK cells due to evolution of better

binding to canine host cell receptors (Hueffer and Parrish, 2003). It is worth noting that after 20 successful passages in either cell line there was evidence of cytopathic effect (CPE). Canine parvovirus does not typically induce CPE and the phenotypic change provides evidence of adaptation to the cell line. This shows that Canine parvovirus continues to evolve in the canine population and warrants continued surveillance and research to better protect susceptible host animals.

CHAPTER 4

SUMMARY OF FINDINGS AND OVERALL CONCLUSIONS

Detection of CPV-2c

This study described for the first time the occurrence of CPV-2c in the United States. Three variants of Canine parvovirus type-2 (2a, 2b, and 2c) are currently circulating in the United States. In addition, we have described a novel mutation that differentiates CPV-2c into “US-like” and “European-like.” Both variants of CPV-2c are widely distributed in the United States (Figure 3.2). We have also found a novel mutation at the 426 residue by serially passaging CPV-2c isolates in A-72 cells. This mutation has not yet been reported in the nature, but may be found circulating in the canine population in the future. Based on findings from the 168 canine originating from 31 states, CPV-2b and CPV-2c are now the predominant strains circulating in the United States.

Canine Parvovirus Attenuation

Both phenotypic and genotypic changes were observed from the serial passaging experiment. Distinct cytopathic effects were observed after 20 passages in both A-72 and CRFK, indicating adaptation of the virus to cell cultures. Similarly, point mutations were introduced during serial passaging of “US-like” and “European-like” CPV-2c isolates. After 50 passages UGA 90, which was a “European-like” strain became a “US-like” strain. This further demonstrates that CPV-2c mutates *in vitro* and may help predict the evolution of CPV-2c in nature.

“US-like” CPV-2c

We found that the “US-like” CPV-2c variants replicate better and exhibit a better immunofluorescent staining in canine kidney cells (A-72) as opposed to feline kidney cells (CRFK). The “US-like” CPV-2c variants seem to be more adapted to the canine host versus “European” CPV-2c variants. The virus titers for the “US-like” CPV-2c isolates were better in hemagglutination (HA) tests overall as compared to “European-like” CPV-2c isolates. The novel mutations in the VP2 capsid of “US-like” CPV-2c isolates may allow this particular virus type to bind to host cell receptors at a higher affinity.

Novel Strains and Evolution of CPV-2

Based on the approximate two-year study on CPV-2 it was determined that all three strains can be found in circulation in the United States. New variants of canine parvovirus were found circulating in the United States. Specifically the “US-like” CPV-2c, which exhibits additional mutations in the 426 antigenic site of the VP2 capsid. Also there was a novel mutation where Glu→Lys *in vitro* that has not been reported in nature. This indicates the future possibility of novel strains emerging in the wild. Canine parvovirus readily evolves as demonstrated *in vitro* using both canine and feline cells. The last report of a novel variant was in 2001 with the report of CPV-2c. A new variant of CPV-2c was reported in 2007 with the “US-like” variant.

Concluding Remarks

Canine parvovirus and its variants deserve continued surveillance due the virus’s ability to rapidly spread and potential to cause a worldwide pandemic. Canine parvovirus continues to infect animals despite vaccination and is still a major relevant veterinary pathogen. Novel mutations that have been observed in this study suggest new variants of Canine parvovirus are still arising in the United States. These new variants may lead to increased host range or

increased pathogenicity. Continued study on these novel variants is necessary to determine the significance of the reported mutational changes. Another reason to continue study is to determine whether the current vaccines protect against both “US-like” CPV-2c and possible novel variants. Since many vaccines are based on the original CPV-2 first reported in 1978 there may be a need for an update on vaccines using a currently circulating variant of Canine parvovirus-2.

REFERENCES

1. Appel MJ, Scott FW, Carmichael LE: 1979, Isolation and immunisation studies of a canine parvo-like virus from dogs with haemorrhagic enteritis. *Vet Rec* 105:156–159.
2. Basak S, Compans RW: 1989, Polarized entry of canine parvovirus in an epithelial cell line. *J Virol* 63:3164–3167.
3. Buonavoglia C, Martella V, et al.: 2001, Evidence for evolution of canine parvovirus type 2 in Italy. *J Gen Virol* 82:3021–3025.
4. Burtonboy G, Coignoul F, et al.: 1979, Canine hemorrhagic enteritis: detection of viral particles by electron microscopy. *Arch Virol* 61:1–11.
5. Carmichael LE: 2005, An annotated historical account of canine parvovirus. *J Vet Med B Infect Dis Vet Public Health* 52:303–311.
6. Carmichael LE, Schlafer DH, et al.: 1994, Minute virus of canines (MVC, canine parvovirus type-1): pathogenicity for pups and seroprevalence estimate. *J Vet Diagn Invest* 6:165–174.
7. Chang SF, Sgro JY, et al.: 1992, Multiple amino acids in the capsid structure of canine parvovirus coordinately determine the canine host range and specific antigenic and hemagglutination properties. *J Virol* 66:6858–6857.
8. Decaro N, Elia G, et al.: 2006, A minor groove binder probe real-time PCR assay for discrimination between type 2-based vaccines and field strains of canine parvovirus. *J Virol Methods* 136:65–70.
9. Decaro N, Elia G, et al.: 2006, Characterisation of the canine parvovirus type 2 variants using minor groove binder probe technology. *J Virol Methods* 133:92–99.

10. Decaro N, Elia G, et al.: 2005, A real-time PCR assay for rapid detection and quantitation of canine parvovirus type 2 in the feces of dogs. *Vet Microbiol* 105:19–28.
11. Decaro N, Martella V, et al.: 2006, First detection of canine parvovirus type 2c in pups with haemorrhagic enteritis in Spain. *J Vet Med B Infect Dis Vet Public Health* 53:468–472.
12. Decaro N, Martella V, et al.: 2006, Diagnostic tools based on minor groove binder probe technology for rapid identification of vaccinal and field strains of canine parvovirus type 2b. *J Virol Methods* 138:10–16.
13. Decaro N, Martella V, et al.: 2007, Tissue distribution of the antigenic variants of canine parvovirus type 2 in dogs. *Vet Microbiol* 121:39–44.
14. Desario C, Decaro N, et al.: 2005, Canine parvovirus infection: which diagnostic test for virus? *J Virol Methods* 126:179–185.
15. Fields BN, Knipe DM, et al.: 2007, *Fields' virology*. Wolters Kluwer Health/Lippincott Williams & Wilkins, Philadelphia, PA.
16. Greene CE: 1998, *Infectious diseases of the dog and cat*. WB Saunders, Philadelphia, PA.
17. Greene CE: 2006, *Infectious diseases of the dog and cat*. Elsevier Saunders, Edinburgh, UK.
18. Greenwood NM, Chalmers WS, et al.: 1995, Comparison of isolates of canine parvovirus by restriction enzyme analysis, and vaccine efficacy against field strains. *Vet Rec* 136:63–67.
19. Hong C, Decaro N, et al.: 2007, Occurrence of canine parvovirus type 2c in the United States. *J Vet Diagn Invest* 19:535–539.
20. Houston DM, Ribble CS, et al.: 1996, Risk factors associated with parvovirus enteritis in dogs: 283 cases 1982–1991. *J Am Vet Med Assoc* 208:542–546.

21. Hueffer K, Parrish CR: 2003, Parvovirus host range, cell tropism and evolution. *Curr Opin Microbiol* 6:392–398.
22. Ikeda Y, Mochizuki M, et al.: 2000, Predominance of canine parvovirus (CPV) in unvaccinated cat populations and emergence of new antigenic types of CPVs in cats. *Virology* 278:13–19.
23. Kapil S, Cooper E, et al.: 2007, Canine parvovirus types 2c and 2b circulating in North American dogs in 2006 and 2007. *J Clin Microbiol* 45:4044–4047.
24. Kelly WR: 1978, An enteric disease of dogs resembling feline panleucopaenia. *Aust Vet J* 54:593–593.
25. Larson LJ, Schultz RD: 1997, Comparison of selected canine vaccines for their ability to induce protective immunity against canine parvovirus infection. *Am J Vet Res* 58:360–363.
26. Martella V, Cavalli A, et al.: 2005, Immunogenicity of an intranasally administered modified live canine parvovirus type 2b vaccine in pups with maternally derived antibodies. *Clin Diagn Lab Immunol* 12:1243–1245.
27. Martella V, Cavalli A, et al.: 2004, A canine parvovirus mutant is spreading in Italy. *J Clin Microbiol* 42:1333–1336.
28. Martella V, Decaro N, et al.: 2005, Surveillance activity for canine parvovirus in Italy. *J Vet Med B Infect Dis Vet Public Health* 52:312–315.
29. Nakamura M, Tohya Y, et al.: 2004, A novel antigenic variant of Canine parvovirus from a Vietnamese dog. *Arch Virol* 149:2261–2269.

30. Palermo LM, Hueffer K, et al.: 2003, Residues in the apical domain of the feline and canine transferrin receptors control host-specific binding and cell infection of canine and feline parvoviruses. *J Virol* 77:8915–8923.
31. Parrish CR, Aquadro CF, et al.: 1991, Rapid antigenic-type replacement and DNA sequence evolution of canine parvovirus. *J Virol* 65:6544–6552.
32. Parrish CR, Carmichael LE: 1986, Characterization and recombination mapping of an antigenic and host range mutation of canine parvovirus. *Virology* 148:121–132.
33. Parrish CR, Have P, et al.: 1988, The global spread and replacement of canine parvovirus strains. *J Gen Virol* 69:1111–1116.
34. Parrish CR, O’Connell PH, et al.: 1985, Natural variation of canine parvovirus. *Science* 230:1046–1048.
35. Pereira CA, Monezi TA, et al.: 2000, Molecular characterization of canine parvovirus in Brazil by polymerase chain reaction assay. *Vet Microbiol* 75:127–133.
36. Pollock RV, Carmichael LE: 1982, Maternally derived immunity to canine parvovirus infection: transfer, decline, and interference with vaccination. *J Am Vet Med Assoc* 180:37–42.
37. Pollock RV, Carmichael LE: 1983, Canine viral enteritis. *Vet Clin North Am Small Anim Pract* 13:551–566.
38. Pratelli A, Cavalli A, et al.: 2001, Canine parvovirus (CPV) vaccination: comparison of neutralizing antibody responses in pups after inoculation with CPV2 or CPV2b modified live virus vaccine. *Clin Diagn Lab Immunol* 8:612–615.
39. Reed AP, Jones EV, et al.: 1988, Nucleotide sequence and genome organization of canine parvovirus. *J Virol* 62:266–276.

40. Strassheim ML, Gruenberg A, et al.: 1994, Two dominant neutralizing antigenic determinants of canine parvovirus are found on the threefold spike of the virus capsid. *Virology* 198:175–184.
41. Tresnan DB, Southard L, et al.: 1995, Analysis of the cell and erythrocyte binding activities of the dimple and canyon regions of the canine parvovirus capsid. *Virology* 211:123–132.
42. Truyen U: 2006, Evolution of canine parvovirus—a need for new vaccines? *Vet Microbiol* 117:9–13.
43. Truyen U, Gruenberg A, et al.: 1995, Evolution of the feline-subgroup parvoviruses and the control of canine host range in vivo. *J Virol* 69:4702–4710.
44. Truyen UWE, Evermann JF, et al.: 1996, Evolution of canine parvovirus involved loss and gain of feline host range. *Virology* 215:186–189.
45. Yule TD, Roth MB, et al.: 1997, Canine parvovirus vaccine elicits protection from the inflammatory and clinical consequences of the disease. *Vaccine* 15:720–729.

APPENDIX

A PERMISSION



Athens Veterinary
Diagnostic Laboratory

College of Veterinary Medicine

Tel. (706) 542-5568
Fax (706) 542-5977

October 31, 2008

Re: permission to Use Copyrighted Material

I request permission for reprinting the following material from Hong et al., Occurrence of canine parvovirus type-2c in the United States, Journal of Veterinary Diagnostic Investigation, September 2007, Volume 19 Issue 5, 535-539.

The requested material will be reprinted in my Master of Science thesis entitled *The Emergence of Novel Strains and Evolution of Canine parvovirus 2 in the United States*, at the University of Georgia.

I understand that you have sole rights to this material. Permission is desired for publication in this thesis only. I shall use the conventional form of acknowledgment, including author, title, publisher's name, and date.

Permission may be granted by filling in the bottom portion of this letter and returning it to me.

Sincerely,

Charles Hong, Graduate Student

=====
Provided proper acknowledgment is given, I hereby grant permission to use the material requested above.

Approved by:

Jeremiah T. Saliki, DVM, PhD, DACVM
Editor-in-Chief, J. Vet. Diagn. Invest.

Date: *November 17, 2008.*

The American Association of Veterinary Laboratory Diagnosticians (AAVLD) holds the copyright to the requested material. Acknowledgement should be given to AAVLD.