

ISOLATION AND CHARACTERIZATION OF TOLUENE METABOLIZING  
BACTERIA FROM THE RHIZOSPHERES OF INDOOR PLANTS

by

HAO ZHANG

(Under the Direction of Mussie Y. Habteselassie)

ABSTRACT

In this study, two species of indoor foliage plants were primed with toluene exposure for two months, followed by isolation and identification of the rhizosphere bacteria that were demonstrated to metabolize toluene. A total of forty-two bacterial isolates were obtained and found similar to eight known bacteria strains, The bacterial isolates were positive for toluene monooxygenase gene, confirming their potential to metabolize toluene. Experiments with  $^{14}\text{C}$ -labeled toluene as the sole carbon source indicated that isolate type did not significantly affect the percent toluene mineralized, The toluene mineralization rate constant (b) was, however, significantly affected by both the isolate type and substrate concentration. Isolate 23 appears to be superior with regard to the speed with which toluene was degraded. The results showed in this study corroborates previous speculation that the rhizosphere microbial community contributes to the phytoremediation potential of indoor foliage plants.

INDEX WORDS: Toluene, volatile organic compounds, rhizosphere bacteria, phytoremediation, indoor plants

ISOLATION AND CHARACTERIZATION OF TOLUENE METABOLIZING  
BACTERIA FROM THE RHIZOSPHERES OF INDOOR PLANTS

By

HAO ZHNAG

B.S., Heilongjiang University, Harbin, P.R. China, 2010

A Thesis Submitted to the Graduate Faculty of The University of Georgia in Partial

Fulfillment of the Requirement for the Degree

MASTER OF SCIENCE

ATHENS, GEORGIA

2013

© 2013

Hao Zhang

All Rights Reserved

ISOLATION AND CHARACTERIZATION OF TOLUENE-METABOLIZING  
BACTERIA FROM RHIZOSPHERES OF INDOOR PLANTS

by

HAO ZHANG

Major Professor: Mussie Y. Habteselassie

Committee: Qingguo (Jack) Huang  
Svoboda (Bodie) V. Pennisi

Electronic Version Approved:

Maureen Grasso  
Dean of the Graduate School  
The University of Georgia  
August 2013

## ACKNOWLEDGMENTS

I would like to express my greatest gratitude to my major advisor, Dr. Mussie Y. Habteselassie, for his direction, comments, remarks, and engagement through out my graduate studies at the University of Georgia Griffin Campus. I would also like to thank Dr. Pennisi and Dr. Huang's great support for offering their lab equipment to my research.

Thank you to our technician Vijaya Mantri, who helped me with experiment design and the preliminary work of this project. Thanks to Diezhang Wu who gives me support and encouragement when I was writing my thesis.

Finally, I want to give the utmost appreciation to my parents, Xiaoqiang Zhan and Suling Wu for their blessing and support in everything I do. Thank you for teaching me to work hard and never stop learning.

## TABLE OF CONTENTS

|  | Page |
|--|------|
| ACKNOWLEDGMENTS .....                                  | iv   |
| LIST OF TABLES .....                                   | vii  |
| LIST OF FIGURES .....                                  | ix   |
| CHAPTER  |      |
| 1 INTRODUCTION .....                                   | 1    |
| REFERENCES .....                                       | 4    |
| 2 LITERATURE REVIEW .....                              | 7    |
| VOLATILE ORGANIC COMPOUNDS .....                       | 7    |
| PHYTOREMEDIATION .....                                 | 13   |
| MICROBIAL DEGRADATION OF CONTAMINANTS .....            | 15   |
| NEW STRAIN SELECTION FOR BIOAUGMENTATION .....         | 18   |
| REFERENCES .....                                       | 21   |
| 3 ISOLATION AND IDENTIFICATION OF TOLUENE METABOLIZING |      |
| BACTERIA FROM RHIZOSPHERES OF TWO INDOOR PLANTS .....  | 38   |
| ABSTRACT .....   | 39   |
| INTRODUCTION .....                                     | 40   |
| MATERIAL AND METHODS .....                             | 42   |
| RESULTS .....  | 47   |

|  |           |
|--|-----------|
| DISCUSSION.....  | 49        |
| REFERENCES .....   | 55        |
| <b>4 GROWTH KINETICS STUDY OF TOLUENE METABOLIZING</b>   |           |
| <b>BACTERIA ISOLATED FROM RHIZOSPHERES OF TWO INDOOR</b> |           |
| <b>PLANTS .....</b>                                      | <b>72</b> |
| <b>ABSTRACT.....</b>                                     | <b>73</b> |
| <b>INTRODUCTION.....</b>                                 | <b>74</b> |
| <b>MATERIAL AND METHODS.....</b>                         | <b>75</b> |
| <b>RESULTS.....</b>                                      | <b>78</b> |
| <b>DISCUSSION.....</b>                                   | <b>80</b> |
| <b>REFERENCES .....</b>                                  | <b>83</b> |
| <b>5 SUMMARY AND CONCLUSIONS .....</b>                   | <b>94</b> |

## LIST OF TABLES

|  | Page |
|--|------|
| Table 2.1. Mechanisms of the phytoremediation.....   | 34   |
| Table 2.2. Examples of plants capable of removing volatile organic compounds (VOCs).<br>.....  | 35   |
| Table 2.3. Biostimulants and their characteristics .....   | 36   |
| Table 2.4. Examples of microorganisms isolated from contaminated sites.....  | 37   |
| Table 3.1. Leaf area and toluene removal efficiency of <i>Hoya carnos</i> a and <i>Fittonia<br/>verschaffeltii</i> var. <i>argyroneura</i> .....   | 64   |
| Table 3.2. Sequence similarities of the isolates against known bacterial strains based on<br>their partial 16S rDNA sequence .....   | 65   |
| Table 3.3. Counts of isolates from the rhizospheres of <i>Hoya carnos</i> a and <i>Fittonia<br/>verschaffeltii</i> var. <i>argyroneura</i> and the corresponding bacterial strains with which they<br>had the highest percent sequence similarity..... | 67   |
| Table 3.4. Percent sequence similarity matrix of the different isolates .....  | 68   |
| Table 4.1. Bacterial isolates that were tested for toluene use efficiency. The isolates were<br>obtained from the rhizospheres of two indoor plants, <i>Hoya carnos</i> a and <i>Fittonia<br/>verschaffeltii</i> var. <i>argyroneura</i> .....         | 86   |

|   |    |
|---|----|
| Table 4.2. Least square means comparisons between substrate concentrations for their effect on percent toluene mineralized over the two weeks incubation time ..... | 87 |
| Table 4.3. Least square means comparisons between isolates for their effect on the decomposition rate constant (b) .....  | 88 |
| Table 4.4. Least square means comparisons between substrate concentrations for their effect on the decomposition rate constant (b) .....                            | 89 |

## LIST OF FIGURES

|   | Page |
|---|------|
| Figure 3.1. BOX-Polymerase Chain Reaction (PCR) banding patterns of isolates obtained from rhizospheres of <i>Hoya carnosa</i> and <i>Fittonia verschaffeltii</i> var. <i>argyroneura</i> .....   | 69   |
| Figure 3.2. A photograph of an agarose gel of polymerase chain reaction (PCR) products for detecting toluene monooxygenase gene in the representative bacterial isolates obtained from rhizospheres of <i>Hoya carnosa</i> and <i>Fittonia verschaffeltii</i> var. <i>argyroneura</i> ..... | 70   |
| Figure 3.3. Phylogenetic tree of bacterial isolates obtained from rhizospheres of <i>Hoya carnosa</i> and <i>Fittonia verschaffeltii</i> var. <i>argyroneura</i> based on their partial 16S rDNA sequence .....   | 71   |
| Figure 4.1. Microcosm set-up for the mineralization study with <sup>14</sup> C labeled toluene.....   | 90   |
| Figure 4.2. Cumulative amount of released <sup>14</sup> CO <sub>2</sub> (disintegration per minute, DPM) from the mineralized toluene over two weeks time .....   | 91   |
| Figure 4.3. Percentage of mineralized toluene after 14 days of incubation.....  | 92   |
| Figure 4.4. Toluene degradation rate constant (b) of isolates under four different concentrations .....   | 93   |

## CHAPTER 1

### INTRODUCTION

Indoor air was commonly believed cleaner than that found outdoors. The National Human Activity Pattern Survey conducted in 1992-94 showed that individuals spent, on average, 87% of their time indoors. Of this percentage 69% was spent in a residence and 17% of the time spent in other indoor locations (Jenkins et al., 1992; Klepeis et al., 2001; Loh et al., 2007). However, studies found that indoor air may be 12 times more polluted than outdoor air (Orwell et al., 2004). Many sources contribute to the indoor air pollution. In particular, Volatile Organic Compounds (VOCs), organic chemical compounds that possess vapor pressures high enough to enter the atmosphere via vaporization, were responsible for 70% of the variation in the total personal exposure (Lee et al., 2002; Loh et al., 2007). The USEPA (1985) Total Exposure Assessment Methodology (TEAM) study has found that concentrations of VOCs in indoor to be two to five times greater than in outdoor air. Over 300 VOCs have been detected as contaminants so far. They include aromatic hydrocarbons (e.g., benzene, toluene, xylene), aliphatic hydrocarbons (e.g., hexane, heptane), halogenated hydrocarbons [e.g., trichloroethylene (TCE), methylene chloride] and terpenes (e.g.,  $\alpha$ -pinene, d-limonene) (Jones, 1999; Wolkoff and Nielsen, 2001). Exposure to VOCs can cause acute illnesses and chronic diseases and some of the VOCs are even suspected or known carcinogens in humans (Suh et al., 2000).

Although the technology for purifying indoor air quality continues to improve, it is often expensive and not being widely used (Bastani et al., 2010; Das et al., 2004; Haghghat et al., 2008). An inexpensive alternative is phytoremediation. In recent years, studies have shown that Indoor plants are able to remove VOCs from indoor air (Darlington et al., 2000; Orwell et al., 2004). For instance, when exposed to benzene, Peace lily (*Spathiphyllum wallisii*) has a high removal efficiency of  $174.5 \text{ ng m}^{-3} \text{ h}^{-1} \text{ cm}^{-2}$  leaf area (Yoo et al., 2006). Additionally, Red Ivy (*Hemigraphis alternata*), Wandering Jew (*Tradescantia pallida*), Asparagus fern (*Asparagus densiflorus*), Wax Plant (*Hoya carnosia*) are able to remove VOCs (a mixture of benzene, toluene octane, TCE and  $\alpha$ -Pinene) with an average efficiency rate of about  $35 \text{ (ng m}^{-3} \text{ h}^{-1} \text{ cm}^{-2} \text{ leaf area)}$  (Yang et al., 2009). Indoor plants are able to absorb VOCs via their stomata during normal gas exchange. Some VOCs are also removed by absorption and adsorption to plant surfaces and soil particles (Orwell et al., 2004).

The rhizosphere is the narrow region of soil that is directly influenced by root secretions and associated soil microorganisms. The rhizosphere consists of sloughed-off plant cells, proteins and sugars released by roots, which can be used by microorganisms as an energy source. Wolverton and Wolverton (1993) suggested that microorganisms within the rhizosphere might play an important role in VOC removal. Studies have shown that when the plants were held in the continuous dark, the VOC removing rate was maintained similar in the light. In addition, when higher concentrations of VOC were added, the removal rates increased further as well (Orwell et al., 2004). Under the dark conditions, plant photosynthesis stops and metabolic activity will be largely reduced. Stomata will also be closed, so there is little gaseous absorption by the leaves.

Furthermore, when the plants were removed from the potting media VOCs continued to disappear at rates comparable with those found prior to the plant's removal. Also, unplanted potting media showed a slow reduction, which is about one third of that with plants (Orwell et al., 2004; Wood et al., 2002). A number of soil microorganisms are capable of degrading toxic chemicals when activated by root growth (Darlington et al., 2000; Wood et al., 2002), though relatively few have been identified to date.

The objective of my thesis was to isolate and genetically characterize toluene metabolizing microorganisms that reside in the rhizospheres of highly efficient VOC-removing indoor plants. These microorganisms were isolated using standard methods from the rhizospheres of two species of indoor plants: *Fittonia verschaffeltii* var. *argyroneura* and *Hoya carnosa* (Yang et al., 2009).

## REFERENCES

- Bastani, A., Lee, C.-S., Haghghat, F., Flaherty, C., and Lakdawala, N. (2010). Assessing the performance of air cleaning devices – A full-scale test method. *Building and Environment* 45, 143-149.
- Darlington, A., Chan, M., Malloch, D., Pilger, C., and Dixon, M. A. (2000). The biofiltration of indoor air: implications for air quality. *Indoor Air* 10, 39-46.
- Das, D., Gaur, V., and Verma, N. (2004). Removal of volatile organic compound by activated carbon fiber. *Carbon* 42, 2949-2962.
- Haghghat, F., Lee, C.-S., Pant, B., Bolourani, G., Lakdawala, N., and Bastani, A. (2008). Evalutaion of various activated carbons for air cleaning - Towards design of immune and sustainalbe buildings. *Atmos. Environ.* 42, 8176-8184.
- Jenkins, P. L., Phillips, T. J., Mulberg, E. J., and Hui, S. P. (1992). Activity patterns of Californians: Use of and proximity to indoor pollutant sources. *Atmospheric Environment. Part A. General Topics* 26, 2141-2148.
- Jones, A. P. (1999). Indoor air quality and health. *Atmos. Environ.* 33, 4535-4564.
- Klepeis, N. E., Nelson, W. C., Ott, W. R., Robinson, J. P., Tsang, A. M., Switzer, P., Behar, J. V., Hern, S. C., and Engelmann, W. H. (2001). The National Human Activity Pattern Survey (NHAPS): a resource for assessing exposure to environmental pollutants. *J Expo Anal Environ Epidemiol* 11, 231-52.
- Lee, S.-C., Guo, H., Li, W.-M., and Chan, L.-Y. (2002). Inter-comparison of air pollutant concentrations in different indoor environments in Hong Kong. *Atmospheric Environment* 36, 1929-1940.

- Loh, M. M., Levy, J. I., Spengler, J. D., Houseman, E. A., and Bennett, D. H. (2007). Ranking cancer risks of organic hazardous air pollutants in the United States. *Environ Health Perspect* 115, 1160-8.
- Orwell, R., Wood, R., Tarran, J., Torpy, F., and Burchett, M. (2004). Removal of Benzene by the Indoor Plant/Substrate Microcosm and Implications for Air Quality. *Water, Air, and Soil Pollution* 157, 193-207.
- Suh, H. H., Bahadori, T., Vallarino, J., and Spengler, J. D. (2000). Criteria air pollutants and toxic air pollutants. *Environ Health Perspect* 108 Suppl 4, 625-33.
- USEPA (1985). The Total Exposure Assessment Methodology (TEAM) Study. Vol. I-IV.
- Wolkoff, P., and Nielsen, G. D. (2001). Organic compounds in indoor air—their relevance for perceived indoor air quality? *Atmospheric Environment* 35, 4407-4417.
- Wolverton, B. C., and Wolverton, J. D. (1993). Plants and soil microorganisms: removal of formaldehyde, xylene, and ammonia from the indoor environment. *Journal of the Mississippi Academy of Sciences* 38, 11-15.
- Wood, R. A., Orwell, R. L., Tarran, J., Torpy, F., and Burchett, M. (2002). Potted-plant/growth media interactions and capacities for removal of volatiles from indoor air. *JOURNAL OF HORTICULTURAL SCIENCE AND BIOTECHNOLOGY* 77, 120-129.
- Yang, D. S., Pennisi, S. V., Son, K., and Kays, S. J. (2009). Screening indoor plants for volatile organic pollutant removal efficiency. *HortScience* 44, 1377-1381.

Yoo, M. H., Kays, S. J., Son, K. C., and Kwon, Y. J. (2006). Efficacy of indoor plants for the removal of single and mixed volatile organic pollutants and physiological effects of the volatiles on the plants. *Journal of the American Society for Horticultural Science* 131, 452-458.

## CHAPTER 2

### LITERATURE REVIEW

#### VOLATILE ORGANIC COMPOUNDS (VOCs)

##### *Biogenic VOC emission*

Terrestrial biosphere is a major source of natural VOCs. VOCs enter the atmosphere through the growth, maintenance, and decay of plants, animals, and microbes (Goldstein and Galbally, 2007; Hines, 2006). On a global scale, biogenic emissions, especially emissions from trees, on an account of over 80% of the total emission, are an order of magnitude greater than the anthropogenic sources (Guenther et al., 1995; Lindfors and Laurila, 2000). But in highly developed areas (e.g. central Europe), biogenic VOC emissions are approximately 50% of the anthropogenic emissions (Zemankova and Brechler, 2010). The VOCs that dominate the biogenic emissions are isoprene and monoterpenes. In a study conducted in Finland, monoterpenes emission contributed 45% of the annual emission, while isoprene contributed about 7% (Lindfors and Laurila, 2000). Plants emit monoterpenes to defend themselves against pathogens, parasites, or herbivores. Other investigations suggest that isoprene formation within plant foliage may serve to prevent light or heat damage. (Holopainen, 2004; Lathièrè et al., 2006; Singaas et al., 1997).

##### *Anthropogenic VOC emissions*

Anthropogenic sources can be generally classified into four main categories: vehicle emissions, solvent utilization (e.g. paint, adhesive, leather agent, and pesticides),

industrial processes (e.g. the manufacture of paint, adhesive, ink, coke, crude oil, gasoline, and pharmaceutical), and stationary fuel combustion (e.g. boilers, combustion turbines, engines, and incinerators), and process heaters (Tassi et al., 2012; Theloke and Friedrich, 2007; Wei et al., 2011). Among these, road transportation and solvent use could account for over 50% of the total VOCs emission (Guo et al., 2004; Wei et al., 2011). VOCs play a central role in the photochemistry of the tropospheric chemistry. In the presence of sunlight and catalyzed by the oxides of nitrogen, VOCs lead to the production of ozone and aerosol (Steinbacher et al., 2005).

### *Indoor VOCs*

Several factors influence the type of VOCs that are found in indoor settings. These include season, flooring, the type of the room, and the size of the apartment, house age, and indoor smoking. The contribution of VOCs from the materials to the indoor air pollution was particularly significant during the first six months after the houses were furnished and ready for occupancy, taking over 2 years to reach the recommended indoor total VOC (TVOC) concentration level, according to a Danish study (Mølhave et al., 1996). Some factors are associated with unique type of VOCs. Wooden floors and new furniture increase the concentration of terpenes. Smokers ventilate their flats to an extent that in general it reduces the VOC concentrations, except for benzene, which was still higher in smoking than in non-smoking flats. Dampness is also associated with an increased VOC load in indoor air. (Schlink et al., 2010; Son et al., 2003)

Ventilation is the most efficient way to control indoor VOC levels associated with these sources, but it entails the increasing costs of building construction, operation, and energy consumption (Cox et al., 2010). Meanwhile, indoor toxic chemical sources are not

necessarily mitigated by simply applying HVAC or filter. A study showed that buildings with HVAC exhibited high indoor and outdoor (I/O) VOC ratios, as did a few of buildings equipped with HVAC and chemical filtration systems (Hisham and Grosjean, 1991) because HVAC system usually contains 15-20% outdoor air and 80-85% of circulated indoor air (Sidheswaran et al., 2012).

The indoor distribution of VOCs is not homogeneous. This unique property that resembles soil may provide an inaccurate indication of personal exposure. Under practical situation, personal exposure maxima could be 10 times higher than the ambient maxima (Son et al., 2003; Wallace, 1991), because individuals are often situated close to emission sources and may also be subjected to air pollutants emitted from substances they commonly come in contact with. Women are more likely to be exposed to VOCs from personal care and household cleaning products, and men tend to be exposed more to tobacco smoke, solvents and paints (Jenkins et al., 1992).

#### *Indoor VOCs sources*

Two major sources contribute to indoor VOCs. First, VOCs from outdoor can enter indoor through the slits of buildings or through the HVAC system; Second, building materials, housekeeping, and cleaning products can emit considerable amount of VOCs. These are the main reasons why residents of low-floor apartments experience high I/O VOC ratio, because low-leveled apartments are more often than not exposed to elevated levels of mobile source-related VOCs as compared to high-floor apartment residents (Jo and Moon, 1999; Jo et al., 2003). Comparing the level of the two sources, a study found that there was no correlation between simultaneously measured indoor and outdoor concentrations, and reported significantly different patterns of diurnal variation. Thus, in

more enclosed and energy efficient buildings indoor emission source strength is considered to be a more significant influence on VOCs concentrations than infiltration of outdoor air (Kim et al., 2001).

Chamber test method has been used for the measurements of VOCs emission from the building materials. The individual testing object is enclosed in a gas-tight chamber with fixed volume, airflow rate, and relative humidity. The VOC concentration is then monitored over time by taking air samples from the test chamber intermediately. Most published inter-laboratory studies have shown coefficients of variation between measured emission rates on the order of 50% and some times as large as 300%. To solve this problem, which is the lack of test validation procedures among different laboratories, a reference material was created by loading toluene into a polymethyl pentene (Cox et al., 2010).

Using the chamber test, numerous studies published their testing results in regards to the emission rate, TOVC, as well as the VOCs species that has been detected. Polymeric materials such as vinyl flooring, carpets and underlays, adhesives, wall-covering materials, caulks, sealants, thermal insulating materials, paints, coatings and varnishes and water-proofing membranes and bituminous emulsions are important sources of indoor VOC emissions (Chuck and Crump, 1998). Solvent-borne paints, coatings and coverings on walls, and ceilings are significant VOC emitters as well. Furnishings and thermal insulators are also important contributors of indoor VOCs. Wood-based products, household products and treatments for stone and masonry are also other sources of VOCs. Liquid applied damp proof membrane products containing coal tar can also emit VOCs.

Although the chamber test has provided data and insight of VOCs emission in indoors, *in situ* identification of emission sources from indoor VOCs is still a challenge. Since that most compounds can be emitted from multiple types of sources, and thus identifying and quantifying sources on the basis of their correlation with several elemental data is limited and difficult because of similar emission characteristics of different sources. And it is difficult to trace the emission sources of the detected compounds clearly (Han et al., 2011). A study previously conducted to deal with this issue showed that unique emission patterns appeared to exist for different types of building materials (Han et al., 2010). These patterns could be established by Proton Transfer Reaction Mass Spectrometry (PTR-MS). Results showed that the proposed method could identify the individual sources under laboratory conditions with multiple materials present.

#### *Health effects of VOCs*

Health effects of VOCs can be diverse, but in general, chronic health effects of VOCs can be categorized into either non-carcinogenic or carcinogenic. Non-carcinogenic chronic effects include irritating, sensory effects, damage to the liver, kidneys and central nervous system, asthma and respiratory inflammation (Ramirez et al., 2012; Rumchev et al., 2007). The main carcinogenic effects are lung, blood, liver, kidney and biliary tract cancers. VOCs are also related to sick-house symptoms. Concentrations of VOCs in the sick-house exceeded the normal level and sometimes 50-200 times higher than the concentrations found in normal houses (Kostiainen, 1995). Several VOCs have been categorized as human carcinogens, among these benzene is the most known. Many other

VOCs were classified as possible and probable carcinogens to humans as well (e.g. trichloroethylene, tetrachloroethylene, ethylbenzene chloroform) (IARC, 2013).

Many studies have been done to examine the non-carcinogenic effects of VOCs. An *in vitro* study was done with human lung epithelial cells to study the cytotoxicity and genotoxicity of VOCs (mainly terpenes and aldehydes). These VOCs are commonly emitted from pinewood and oriented strand boards. The results showed that high concentrations of these VOCs and VOC mixtures did not lead to adverse effects in human lung cells even at concentrations  $10^2$  to  $10^5$  fold higher than those found in normal indoor air (Gminski et al., 2010). *In vitro* and *in vivo* studies with mouse under the exposure of polyvinyl chloride (PVC) flooring showed that exposure to VOCs may increase the allergic immune response and therefore need to be considered as a risk factor for the development of allergic diseases (Bonisch et al., 2012). Other studies with mouse under the exposure of mixture of VOCs (formaldehyde, benzene, toluene, and xylene) found that both short- and long-term VOCs exposures might induce low airway inflammation (Fujimaki et al., 2007; Wang et al., 2012a). House painters might be at risk of adverse physiological reactions in the ocular and nasal mucosa (Wieslander and Norback, 2010). VOCs can also react with hydroxyl radicals, ozone, and nitrate radicals to form secondary oxidation products or secondary pollutants. These pollutants cannot be detected with conventional sampling methods, and they may cause more severe effects compared to the parent compounds (Anderson et al., 2013).

## PHYTOREMEDIATION

Phytoremediation is defined as the use of green plants to remove pollutants from the environment or to render them harmless. It is cost effective and environment-friendly (Raskin et al., 1997). Plants have constitutive and adaptive mechanisms for accumulation or tolerating high concentration of contaminants in their rhizospheres. Based on the mechanism of phytoremediation, different process names have been given (Table 2.1). The target pollutant of phytoremediation can be both elemental and organic pollutants. Elemental pollutants include toxic heavy metals and radio-nucleotides, such as arsenic, cadmium, cesium, chromium, lead, mercury, strontium, tritium and uranium (Farias et al., 2011). Organic pollutants that are potentially important targets for phytoremediation include polychlorinated biphenyls (PCBs), polycyclic aromatic hydrocarbons (PAHs), nitroaromatics, linear halogenated hydrocarbons (LHH), and pesticides (Hamdi et al., 2012; Panz and Miksch, 2012; Wang et al., 2012b).

### *Phytoremediation with indoor plants*

Phytoremediation of indoor air utilizes plants to remove or neutralize environmental contaminants such as VOCs in the air of homes, offices and other enclosed buildings (Kays, 2011). In the early 1970s, NASA started to screen the air inside the spacecraft out of the concern of the air quality of airtight space. Experiments carried out in the 1970s with  $^{14}\text{C}$  labeled aromatic hydrocarbons found that benzene and toluene were assimilated by plants grown under sterile conditions, and that the aromatic ring of these molecules was cleaved during their metabolic transformation (Durmishidze, 1975; Ugrekhelidze, 1976). In 1984, a study examined the uptake and conversion of gaseous alkanes, cyclohexane, monocyclic aromatic hydrocarbons, polycyclic carcinogenic

hydrocarbons, phenols, and some pesticides by annual and perennial plants. This study demonstrated that benzene and toluene were mainly uptaken by the plant leaves (Ugrekheldze and Durmishidze, 1984; Ugrekheldze et al., 1997). NASA at the same time published a report that first detailed the ability of indoor plants to remove VOCs in sealed chambers (Wolverton et al., 1984). Since then increasing number of studies have demonstrated the ability of different plants to remove VOCs. Some examples of such studies are listed in Table 2.2.

#### *Mechanisms of VOCs mineralization in plants*

The assimilation of aromatic hydrocarbons by plant leaves involves two steps: absorption and transformation. The level of the absorption depends on the number of stomata and the structure of the cuticle. Transformation is determined by activity of enzyme systems involved. The intensity of the transformation of hydrocarbons in plants is determined by a number of factors, including the rate of their penetration and localization, the activity and specificity of oxidizing enzyme systems transforming aromatic hydrocarbons, the reaction type, and the chemical nature of the hydrocarbon (Ugrekheldze et al., 1997). Schmitz et al. (2000) found that  $^{14}\text{C}$ -formaldehyde assimilation under light was about five times more than its assimilation in the dark. He suggested that in the presence of light,  $^{14}\text{C}$  enters the Calvin cycle after an enzymatic two-step oxidation process of  $^{14}\text{C}$ -formaldehyde to  $^{14}\text{CO}_2$ .

It is now well established that microorganisms, in particular bacteria, are a critical part of the phytoremediation response. Their role is important since they are more likely to be able to effectively metabolize the diverse range of chemical pollutants found in indoor air. However, there is not much information about rhizosphere bacteria when it

comes to species types, population dynamics, changes in gene expression in response to specific VOCs, sensitivity to VOCs, and their relationship to different indoor plants (Kays, 2011).

## MICROBIAL DEGRADATION OF CONTAMINANTS

Bioremediation is the process where organic wastes are biologically degraded under controlled conditions to a level that takes the waste below the concentration limits. Manipulation of environmental parameters is required to allow microbial growth and degradation to proceed at a faster rate for the process to achieve its goals. Bioremediation is attractive because it is more economical than traditional methods such as incineration, and some pollutants can be treated on site (Kumar et al., 2011; Shilpi, 2012). The different bioremediation techniques are discussed below.

### *Natural attenuation*

The natural, non-engineered process of degradation of xenobiotics by the indigenous microbial population is referred to as natural attenuation, and is regarded as the simplest form of bioremediation. When pollutants enter a site as xenobiotics, the composition of indigenous microbial population in the soil or water will act to adapt to this new situation (Liu and Suflita, 1993). In spite of many obstacles, most of the xenobiotic organic compounds can become biodegradable after the bacterial population has gained degradation capability through the process of acclimation (Buitron et al., 1998; Singleton, 1994).

Monitored natural attenuation is the most widely used bioremediation technique. Chemical parameters like concentration of xenobiotics, intermediate formation, end

product formation, and electron acceptor consumption can be monitored by analytical equipment. Methods to monitor biological parameter such as the composition, size, and degrading activity of the microbial population include enumeration using plate counts, total DNA extraction, direct mRNA isolation, metabolic biomarkers, and the use of reporter bacteria. Time is the limiting factor that impedes the large-scale application of natural attenuation, since the adaptation of indigenous microorganisms can take a long time (Leahy and Colwell, 1990).

### *Biostimulation*

Biostimulation uses indigenous microbial community but stimulates desired degrader by adding suitable electron donors or electron acceptors (Table 2.3) that are not available in high concentration in the soil (Mehrdad et al., 2008; Meiyong et al., 2010). Limited field studies have been performed to date but information gathered through laboratory stimulation can aid in determining the applications of this technique for pollutant remediation. The two largest studies examined uranium remediation in Oak Ridge, Tennessee and Rifle, Colorado and provided a basic template for other *in situ* biostimulation techniques (Vrionis et al., 2005). Smaller studies have also been completed with gasoline in Bellingham, WA and polychlorinated ethylene at various factory sites (Gregory and Lovley, 2005; Sublette et al., 2006). During a field study, a set of injection wells are drilled to reach ground water, with the exact locations being site specific. Monitoring wells are drilled both up and down flow of the injection wells for sampling. The biostimulant is injected at an appropriate concentration for a specified interval.

### *Bioaugmentation*

Bioaugmentation is the introduction of microorganisms with specific catabolic abilities into the contaminated environment in order to supplement the indigenous population and to speed up or enable the degradation of pollutants (Perelo, 2010).

Bioaugmentation with specialized microorganisms is necessary if the catabolic potential for degradation of the target compounds is lacking or incomplete in the microbial community of the polluted site. This is often the case for highly recalcitrant compounds such as PCBs, dioxins, and other chlorinated aromatics (Blasco et al., 1995; Blumenroth and Wagner-Döbler, 1998; Erb et al., 1997).

The key factor to successful bioaugmentation is the selection of the appropriate bacterial strain. So far numerous species of bacteria have been isolated from contaminated sites (Table 2.4). Efficacy of bioaugmentation is still controversial. Bioaugmentation has proven successful in both soil and aquatic environment (Juhasz and Naidu, 2000). Still, there are many examples where bioaugmentation has not been effective. Reasons for these failures include nutrient limitations, suppression by predators and parasites, poor transport of bacteria through soil, and low substrate concentration, all of which contribute to poor survival and activity of the inoculum (Bouchez et al., 2000; Goldstein et al., 1985; Tam and Wong, 2008). The success of bioaugmentation thus is dependent on maintaining a high population density of active degrader organisms. Several studies have been conducted to resolve this problem.

Gilbert and Crowley found that repeated application of carvone-induced bacteria was the most effective treatment for mineralizing PCB, whereas a single application of inoculum resulted in no significant degradation. This is probably because when soil is

being repeatedly inoculated with active inoculants, long-term availability of the degrader is ensured. Degrader bacteria are also maintained at high activity. Moreover, repeated applications may also increase the cell distribution among soil (Gilbert and Crowley, 1998). Surfactant addition has proven to be an effective method in bioremediation as well. Repeated addition of surfactant and carvone to non-inoculated soil resulted in 30-36% more PCB removal by the indigenous soil bacteria (Singer et al., 2000). Surfactant increases the bioavailability of PCB in soil. Another factor is the introduction of single strain versus a cocktail of bacterial populations, which are more efficient due to the presence of co-degradation (Pelz et al., 1999). Bacteria consortium, each with different parts of the catabolic degradation route, is often found to be more efficient than a single strain (Rahman et al., 2002).

Indigenous strains have been assumed to be superior to nonindigenous strains with respect to inoculation efficiency. However, the use of indigenous isolates for bioremediation does not provide any advantage in dynamic, highly competitive environments. To ensure survival of the inoculant, either the site must be engineered to provide a temporary advantage for the introduced strain, or the inoculant must be able to exploit a specific niche better than the indigenous microbial community (Blumenroth and Wagner-Döbler, 1998).

## NEW STRAIN SELECTION FOR BIOAUGMENTATION

### *In rhizo-directed strain selection*

In many cases, superior degrader isolation relies on the ability of the isolate to grow rapidly on a specific carbon source in defined chemical and environmental

laboratory conditions (Kuiper et al., 2004). In rhizo-directed strain selection enables the selection of microorganism with the capacity to grow on root exudates within the rhizosphere in addition to degrading the relevant pollutant. The microorganisms, once inoculated into the appropriate plant rhizosphere, would express the pollutant-degrading enzymes, thereby decontaminating the soil while still benefitting from the plant root exudates to sustain its population and metabolic activity (Singer et al., 2003; Singer et al., 2004). The inoculum, in return, can provide protection to the plant against phytotoxic chemicals and plant pathogens. The synergistic relationship between the plant and the inoculum established by this approach is arguably more resilient, sustainable and cost-effective than the standard bioaugmentation approach. Reliance of the inoculum on plant exudates for survival precludes its unintended dispersal to non-target soils, thereby providing a mechanism for addressing public safety concerns.

#### *'Priming' strain selection*

Priming is described as predisposing an isolate or population of microorganisms to future conditions in which they are designed to perform a function (Singer et al., 2005). Priming is firstly used in probiotic yogurt culture preparation. Now, the priming approach has also been effectively demonstrated in environmental systems, whereby clean soil is enriched for pollutant-degrading microorganisms by repeated biostimulation with the relevant pollutants. Then the soil itself will be used as the inoculum for the target polluted soil (Gentry et al., 2004). This approach has several advantages: firstly, the inoculum is a consortium of indigenous microorganisms which is potentially more resilient to stress than a single isolate. Secondly, the 'primed' consortium is maintained within its native soil, potentially enhancing its survival in the target soil. Thirdly, unculturable

microorganisms, which might contain one or more highly competent pollutant degraders, are included. In addition, the approach is theoretically to solving the issue of co-contaminated soil (Singer et al., 2005).

## REFERENCES

- Anderson, S. E., Khurshid, S. S., Meade, B. J., Lukomska, E., and Wells, J. R. (2013). Toxicological analysis of limonene reaction products using an in vitro exposure system. *Toxicol In Vitro* 27, 721-30.
- Begley, J., Czarnecki, M., Kemen, S., Verardo, A., Robb, A., Fogel, S., and Begley, G. (2012). Oxygen and ethene biostimulation for a persistent dilute vinyl chloride plume. *Ground Water Monitoring & Remediation* 32, 99-105.
- Blasco, R., Wittich, R. M., Mallavarapu, M., Timmis, K. N., and Pieper, D. H. (1995). From xenobiotic to antibiotic, formation of protoanemonin from 4-chlorocatechol by enzymes of the 3-oxoadipate pathway. *J Biol Chem* 270, 29229-35.
- Blumenroth, P., and Wagner-Döbler, I. (1998). Survival of Inoculants in Polluted Sediments: Effect of Strain Origin and Carbon Source Competition. *Microbial Ecology* 35, 279-288.
- Bonisch, U., Bohme, A., Kohajda, T., Mogel, I., Schutze, N., von Bergen, M., Simon, J. C., Lehmann, I., and Polte, T. (2012). Volatile Organic Compounds Enhance Allergic Airway Inflammation in an Experimental Mouse Model. *PLoS ONE* 7, e39817.
- Bouchez, T., Patureau, D., Dabert, P., Juretschko, S., Dore, J., Delgenes, P., Moletta, R., and Wagner, M. (2000). Ecological study of a bioaugmentation failure. *Environ Microbiol* 2, 179-90.
- Buitron, G., Gonzalez, A., and Lopez-Marin, L. M. (1998). Biodegradation of phenolic compounds by an acclimated activated sludge and isolated bacteria. *Water Science & Technology* 37, 371.

- Chuck, Y., and Crump, D. (1998). A Review of the Emission of VOCs from Polymeric Materials used in Buildings. *Building and Environment* 33, 357-374.
- Cox, S. S., Liu, Z., Little, J. C., Howard-Reed, C., Nabinger, S. J., and Persily, A. (2010). Diffusion-controlled reference material for VOC emissions testing: proof of concept. *Indoor Air* 20, 424-33.
- Cybulski, Z., Dziurla, E., Kaczorek, E., and Olszanowski, A. (2003). The Influence of Emulsifiers on Hydrocarbon Biodegradation by Pseudomonadacea and Bacillacea Strains. *Spill Science & Technology Bulletin* 8, 503-507.
- Da Silva, M. L., Ruiz-Aguilar, G. M., and Alvarez, P. J. (2005). Enhanced anaerobic biodegradation of BTEX-ethanol mixtures in aquifer columns amended with sulfate, chelated ferric iron or nitrate. *Biodegradation* 16, 105-14.
- Di Martino, C., López, N. I., and Raiger Iustman, L. J. (2012). Isolation and characterization of benzene, toluene and xylene degrading Pseudomonas sp. selected as candidates for bioremediation. *International Biodeterioration & Biodegradation* 67, 15-20.
- Dou, J., Liu, X., Hu, Z., and Deng, D. (2008). Anaerobic BTEX biodegradation linked to nitrate and sulfate reduction. *Journal of Hazardous Materials* 151, 720-729.
- Durmishidze, S. V. (1975). "Cleavage of the aromatic ring of some exogenous compounds in plants," Metsniereba, Tbilisi, Russian.
- Erb, R. W., Eichner, C. A., Wagner-Dobler, I., and Timmis, K. N. (1997). Bioprotection of microbial communities from toxic phenol mixtures by a genetically designed pseudomonad. *Nat Biotechnol* 15, 378-82.

- Farias, P. C. d. M.-., Chaves, A. L. S., and Lencina, C. L. (2011). "Transgenic Plants for Enhanced Phytoremediation – Physiological Studies."
- Fujimaki, H., Yamamoto, S., Tin Tin Win, S., Hojo, R., Sato, F., Kunugita, N., and Arashidani, K. (2007). Effect of long-term exposure to low-level toluene on airway inflammatory response in mice. *Toxicol Lett* 168, 132-9.
- Gentry, T., Josephson, K., and Pepper, I. (2004). Functional Establishment of Introduced Chlorobenzoate Degraders Following Bioaugmentation with Newly Activated Soil. *Biodegradation* 15, 67-75.
- Gilbert, E. S., and Crowley, D. E. (1998). Repeated application of carvone-induced bacteria to enhance biodegradation of polychlorinated biphenyls in soil. *Appl Microbiol Biotechnol* 50, 489-94.
- Gminski, R., Tang, T., and Mersch-Sundermann, V. (2010). Cytotoxicity and genotoxicity in human lung epithelial A549 cells caused by airborne volatile organic compounds emitted from pine wood and oriented strand boards. *Toxicol Lett* 196, 33-41.
- Goldstein, A. H., and Galbally, I. E. (2007). Known and Unexplored Organic Constituents in the Earth's Atmosphere. *Environmental Science and Technology*, 1515-1521.
- Goldstein, R. M., Mallory, L. M., and Alexander, M. (1985). Reasons for possible failure of inoculation to enhance biodegradation. *Appl Environ Microbiol* 50, 977-83.
- Gradova, N. B., Gornova, I. B., Eddaoudi, R., and Salina, R. N. (2003). Use of Bacteria of the Genus *Azotobacter* for Bioremediation of Oil-Contaminated Soils. *Applied Biochemistry and Microbiology* 39, 279-281.

- Gregory, K. B., and Lovley, D. R. (2005). Remediation and recovery of uranium from contaminated subsurface environments with electrodes. *Environmental Science & Technology* 39, 8943-8947.
- Guenther, A., Hewitt, C. N., Erickson, D., Fall, R., Geron, C., Graedel, T., Harley, P., Klinger, L., Lerdau, M., McKay, W. A., Pierce, T., Scholes, B., Steinbrecher, R., Tallamraju, R., Taylor, J., and Zimmerman, P. (1995). A global model of natural volatile organic compound emissions. *Journal of Geophysical Research: Atmospheres* 100, 8873-8892.
- Guo, H., Wang, T., Simpson, I. J., Blake, D. R., Yu, X. M., Kwok, Y. H., and Li, Y. S. (2004). Source contributions to ambient VOCs and CO at a rural site in eastern China. *Atmospheric Environment* 38, 4551-4560.
- Hamdi, H., Benzarti, S., Aoyama, I., and Jedidi, N. (2012). Rehabilitation of degraded soils containing aged PAHs based on phytoremediation with alfalfa (*Medicago sativa* L.). *International Biodeterioration & Biodegradation* 67, 40-47.
- Han, K. H., Zhang, J. S., Knudsen, H. N., Wargocki, P., Chen, H., Varshney, P. K., and Guo, B. (2011). Development of a novel methodology for indoor emission source identification. *Atmospheric Environment* 45, 3034-3045.
- Han, K. H., Zhang, J. S., Wargocki, P., Knudsen, H. N., and Guo, B. (2010). Determination of material emission signatures by PTR-MS and their correlations with odor assessments by human subjects. *Indoor Air* 20, 341-354.
- Hines, P. J. (2006). The Invisible Bouquet. *Science* 311, 803.
- Hisham, M. W. M., and Grosjean, D. (1991). Air pollution in southern California museums: Indoor and outdoor levels of nitrogen dioxide, peroxyacetyl nitrate,

nitric acid, and chlorinated hydrocarbons. *Journal Name: Environmental Science and Technology; (United States); Journal Volume: 25:5, Medium: X; Size: Pages: 857-862.*

Holopainen, J. K. (2004). Multiple functions of inducible plant volatiles. *Trends in Plant Science* 9, 529-533.

IARC (2013). List of classifications by alphabetical order.

<http://monographs.iarc.fr/ENG/Classification/index.php> Accessed June 5, 2013.

Jenkins, P. L., Phillips, T. J., Mulberg, E. J., and Hui, S. P. (1992). Activity patterns of Californians: Use of and proximity to indoor pollutant sources. *Atmospheric Environment. Part A. General Topics* 26, 2141-2148.

Jo, W.-K., and Moon, K.-C. (1999). Housewives' exposure to volatile organic compounds relative to proximity to roadside service stations. *Atmospheric Environment* 33, 2921-2928.

Jo, W. K., Kim, K. Y., Park, K. H., Kim, Y. K., Lee, H. W., and Park, J. K. (2003). Comparison of outdoor and indoor mobile source-related volatile organic compounds between low- and high-floor apartments. *Environ Res* 92, 166-71.

Juhasz, A. L., and Naidu, R. (2000). Bioremediation of high molecular weight polycyclic aromatic hydrocarbons: a review of the microbial degradation of benzo[a]pyrene. *International Biodeterioration & Biodegradation* 45, 57-88.

Kafilzadeh, F., and Pour, F. H. (2012). Degradation of naphthalene, phenanthrene and pyrene by *Pseudomonas* sp. and *Corynebacterium* sp. in the landfills. *International Journal of Biosciences (IJB)* 2, 77-84.

- Kafilzadeh, F., Pour, F. H., Tahery, Y., and Azad, H. N. (2012). Bioremediation of pyrene by isolated bacterial strains from the soil of the landfills in Shiraz (Iran). *Annals of Biological Research* 3, 486-494.
- Kapley, A., Purohit, H. J., Chhatre, S., Shanker, R., Chakrabarti, T., and Khanna, P. (1999). Osmotolerance and hydrocarbon degradation by a genetically engineered microbial consortium. *Bioresource Technology* 67, 241-245.
- Kays, S. J. (2011). Phytoremediation of indoor air - current state of the art. In "The Value Creation of Plants for Future Urban Agriculture " (K. J. Kim, ed.), pp. 3-21. Nat. Inst. Hort. Herbal Science, RDA, Suwon, Korea.
- Kim, Y. M., Harrad, S., and Harrison, R. M. (2001). Concentrations and sources of VOCs in urban domestic and public microenvironments. *Environ Sci Technol* 35, 997-1004.
- Kostiainen, R. (1995). Volatile organic compounds in the indoor air of normal and sick houses. *Atmospheric Environment* 29, 693-702.
- Kuiper, I., Lagendijk, E. L., Bloemberg, G. V., and Lugtenberg, B. J. (2004). Rhizoremediation: a beneficial plant-microbe interaction. *Mol Plant Microbe Interact* 17, 6-15.
- Kumar, A., Bisht, B. S., Joshi, V. D., and Dhewa, T. (2011). Review on bioremediation of polluted environment: a management tool. *International Journal of Environmental Sciences* 1, 1079-1093.
- Lal, B., and Khanna, S. (1996). Degradation of crude oil by *Acinetobacter calcoaceticus* and *Alcaligenes odorans*. *J Appl Bacteriol* 81, 355-62.

- Lathière, J., Hauglustaine, D. A., Friend, A. D., De Noblet-Ducoudré, N., Viovy, N., and Folberth, G. A. (2006). Impact of climate variability and land use changes on global biogenic volatile organic compound emissions. *Atmos. Chem. Phys.* 6, 2129-2146.
- Le, N. B., and Coleman, N. V. (2011). Biodegradation of vinyl chloride, cis-dichloroethene and 1,2-dichloroethane in the alkene/alkane-oxidising *Mycobacterium* strain NBB4. *Biodegradation* 22, 1095-108.
- Leahy, J. G., and Colwell, R. R. (1990). Microbial degradation of hydrocarbons in the environment. *Microbiol Rev* 54, 305-15.
- Lindfors, V., and Laurila, T. (2000). Biogenic volatile organic compound (VOC) emissions from forest in Finland. *Boreal Environment Research* 5, 95-113.
- Liu, S., and Suflita, J. M. (1993). Ecology and evolution of microbial populations for bioremediation. *Trends Biotechnol* 11, 344-52.
- Liu, Y.-J., Mu, Y.-J., Zhu, Y.-G., Ding, H., and Crystal Arens, N. (2007). Which ornamental plant species effectively remove benzene from indoor air? *Atmospheric Environment* 41, 650-654.
- Mehrdad, F., Cédric, V., David, D., and Christian, L. (2008). Review: In situ bioremediation of monoaromatic pollutants in groundwater: A review. *Bioresource Technology* 99, 5296-5308.
- Meiying, X., Wei-Min, W., Liyou, W., Zhili, H., Van Nostrand, J. D., Ye, D., Jian, L., Carley, J., Ginder-Vogel, M., Gentry, T. J., Baouhua, G., Watson, D., Jardine, P. M., Marsh, T. L., Tiedje, J. M., Hazen, T., Criddle, C. S., and Jizhong, Z. (2010). Responses of microbial community functional structures to pilot-scale uranium in

- situ bioremediation. *ISME Journal: Multidisciplinary Journal of Microbial Ecology* 4, 1060-1070.
- Mølhav, L., Sparks, L. E., Wolkoff, P., Clausen, P. A., Nielsen, P. A., and Bergsø, N. C. (1996). The Danish Twin Apartment Study – Part II: Mathematical modeling of the relative strength of sources of indoor air pollution. *Indoor Air* 6, 18-30.
- Ning, J., Gang, G., Bai, Z., Hu, Q., Qi, H., Ma, A., Zhuan, X., and Zhuang, G. (2012). In situ enhanced bioremediation of dichlorvos by a phyllosphere *Flavobacterium* strain. *Frontiers of Environmental Science & Engineering* 6, 231-237.
- Nyman, J., Gentile, M., and Criddle, C. (2007). Sulfate requirement for the growth of U(VI)-reducing bacteria in an ethanol-fed enrichment. *Bioremediation Journal* 11, 21-32.
- Orwell, R., Wood, R., Tarran, J., Torpy, F., and Burchett, M. (2004). Removal of Benzene by the Indoor Plant/Substrate Microcosm and Implications for Air Quality. *Water, Air, and Soil Pollution* 157, 193-207.
- Panz, K., and Miksch, K. (2012). Phytoremediation of explosives (TNT, RDX, HMX) by wild-type and transgenic plants. *J Environ Manage* 113, 85-92.
- Pelz, O., Tesar, M., Wittich, R. M., Moore, E. R., Timmis, K. N., and Abraham, W. R. (1999). Towards elucidation of microbial community metabolic pathways: unravelling the network of carbon sharing in a pollutant-degrading bacterial consortium by immunocapture and isotopic ratio mass spectrometry. *Environ Microbiol* 1, 167-74.
- Perelo, L. W. (2010). Review: In situ and bioremediation of organic pollutants in aquatic sediments. *Journal of Hazardous Materials* 177, 81-89.

- Rahman, K. S., Rahman, T., Lakshmanaperumalsamy, P., and Banat, I. M. (2002). Occurrence of crude oil degrading bacteria in gasoline and diesel station soils. *J Basic Microbiol* 42, 284-91.
- Ramirez, N., Cuadras, A., Rovira, E., Borrull, F., and Marce, R. M. (2012). Chronic risk assessment of exposure to volatile organic compounds in the atmosphere near the largest Mediterranean industrial site. *Environ Int* 39, 200-9.
- Raskin, I. I., Smith, R. D., and Salt, D. E. (1997). Phytoremediation of metals: using plants to remove pollutants from the environment. *Curr Opin Biotechnol* 8, 221-6.
- Rumchev, K., Brown, H., and Spickett, J. (2007). Volatile organic compounds: do they present a risk to our health? *Rev Environ Health* 22, 39-55.
- Schlink, U., Thiem, A., Kohajda, T., Richter, M., and Strebel, K. (2010). Quantile regression of indoor air concentrations of volatile organic compounds (VOC). *Sci Total Environ* 408, 3840-51.
- Schmitz, H., Hilgers, U. T. E., and Weidner, M. (2000). Assimilation and metabolism of formaldehyde by leaves appear unlikely to be of value for indoor air purification. *New Phytologist* 147, 307-315.
- Sheoran, V., Sheoran, A. S., and Poonia, P. (2012). PHYTOREMEDIATION TECHNOLOGIES FOR THE RECLAMATION OF ORGANIC AND INORGANIC POLLUTED SOILS AND WATER: A REVIEW. *Environmental Research Journal* 6, 393.
- Shilpi, S. (2012). Bioremediation: features, strategies and applications. *Asian Journal of Pharmacy and Life Science* 2, 202-213.

- Sidheswaran, M. A., Destailats, H., Sullivan, D. P., Cohn, S., and Fisk, W. J. (2012). Energy efficient indoor VOC air cleaning with activated carbon fiber (ACF) filters. *Building and Environment* 47, 357-367.
- Singer, A. C., Crowley, D. E., and Thompson, I. P. (2003). Secondary plant metabolites in phytoremediation and biotransformation. *Trends Biotechnol* 21, 123-30.
- Singer, A. C., Gilbert, E. S., Luepromchai, E., and Crowley, D. E. (2000). Bioremediation of polychlorinated biphenyl-contaminated soil using carvone and surfactant-grown bacteria. *Appl Microbiol Biotechnol* 54, 838-43.
- Singer, A. C., Thompson, I. P., and Bailey, M. J. (2004). The tritrophic trinity: a source of pollutant-degrading enzymes and its implications for phytoremediation. *Curr Opin Microbiol* 7, 239-44.
- Singer, A. C., van der Gast, C. J., and Thompson, I. P. (2005). Perspectives and vision for strain selection in bioaugmentation. *Trends Biotechnol* 23, 74-77.
- Singleton, I. (1994). Microbial metabolism of xenobiotics: fundamental and applied research. *J. Chem. Technol. Biotechnol., Chem. Technol.*, 9.
- Singsaas, E. L., Lerdaun, M., Winter, K., and Sharkey, T. D. (1997). Isoprene Increases Thermotolerance of Isoprene-Emitting Species. *Plant Physiol* 115, 1413-1420.
- Son, B., Breyse, P., and Yang, W. (2003). Volatile organic compounds concentrations in residential indoor and outdoor and its personal exposure in Korea. *Environ Int* 29, 79-85.
- Steinbacher, M., Dommen, J., Ordonez, C., Reimann, S., GrÜebler, F. C., Staehelin, J., and Prevot, A. S. H. (2005). Volatile Organic Compounds in the Po Basin. Part A: Anthropogenic VOCs. *Journal of Atmospheric Chemistry* 51, 271-291.

- Sublette, K., Peacock, A., White, D., Davis, G., Ogles, D., Cook, D., Kolhatkar, R., Beckmann, D., and Yang, X. (2006). Monitoring Subsurface Microbial Ecology in a Sulfate-Amended, Gasoline-Contaminated Aquifer. *Ground Water Monitoring & Remediation* 26, 70-78.
- Syakti, A. D., Yani, M., Hidayati, N. V., Siregar, A. S., Doumenq, P., and Made Sudiana, I. M. (2013). The Bioremediation Potential of Hydrocarbonoclastic Bacteria Isolated From a Mangrove Contaminated by Petroleum Hydrocarbons on the Cilacap Coast, Indonesia. *Bioremediation Journal* 17, 11-20.
- Tam, N. F. Y., and Wong, Y. S. (2008). Effectiveness of bacterial inoculum and mangrove plants on remediation of sediment contaminated with polycyclic aromatic hydrocarbons. *Marine Pollution Bulletin* 57, 716-726.
- Tassi, F., Capecchiacci, F., Buccianti, A., and Vaselli, O. (2012). Sampling and analytical procedures for the determination of VOCs released into air from natural and anthropogenic sources: A comparison between SPME (Solid Phase Micro Extraction) and ST (Solid Trap) methods. *Applied Geochemistry* 27, 115-123.
- Theloke, J., and Friedrich, R. (2007). Compilation of a database on the composition of anthropogenic VOC emissions for atmospheric modeling in Europe. *Atmospheric Environment* 41, 4148-4160.
- Ugrekheldze, D. (1976). "Metabolism of Exogenous Alkanes and Aromatic Hydrocarbons in Plants," Metsniereba, Tbilisi, Russian.
- Ugrekheldze, D., and Durmishidze, S. V. (1984). "Penetration and Detoxication of Organic Xenobiotics in Plants " Metsniereba, Tbilisi, Russian.

- Ugrekheldze, D., Korte, F., and Kvesitadze, G. (1997). Uptake and transformation of benzene and toluene by plant leaves. *Ecotoxicol Environ Saf* 37, 24-9.
- Verma, A., Ali, D., Farooq, M., Pant, A. B., Ray, R. S., and Hans, R. K. (2011). Expression and inducibility of endosulfan metabolizing gene in *Rhodococcus* strain isolated from earthworm gut microflora for its application in bioremediation. *Bioresour Technol* 102, 2979-84.
- Vrionis, H. A., Anderson, R. T., Ortiz-Bernad, I., O'Neill, K. R., Resch, C. T., Peacock, A. D., Dayvault, R., White, D. C., Long, P. E., and Lovley, D. R. (2005). Microbiological and Geochemical Heterogeneity in an In Situ Uranium Bioremediation Field Site. *Applied and Environmental Microbiology* 71, 6308-6318.
- Wallace, L. A. (1991). Personal exposure to 25 volatile organic compounds. EPA's 1987 team study in Los Angeles, California. *Toxicol Ind Health* 7, 203-8.
- Wang, F., Li, C., Liu, W., and Jin, Y. (2012a). Effect of exposure to volatile organic compounds (VOCs) on airway inflammatory response in mice. *J Toxicol Sci* 37, 739-48.
- Wang, M. C., Chen, Y. T., Chen, S. H., Chang Chien, S. W., and Sunkara, S. V. (2012b). Phytoremediation of pyrene contaminated soils amended with compost and planted with ryegrass and alfalfa. *Chemosphere* 87, 217-25.
- Wei, W., Wang, S., Hao, J., and Cheng, S. (2011). Projection of anthropogenic volatile organic compounds (VOCs) emissions in China for the period 2010–2020. *Atmospheric Environment* 45, 6863-6871.

- Wieslander, G., and Norback, D. (2010). Ocular symptoms, tear film stability, nasal patency, and biomarkers in nasal lavage in indoor painters in relation to emissions from water-based paint. *Int Arch Occup Environ Health* 83, 733-41.
- Wolverton, B. C., McDonald, R. C., and Watkins, E. A., Jr. (1984). Foliage plants for removing indoor air pollutants from energy-efficient homes. *Econ. Bot.; (United States)* 224.
- Xie, H., Zhu, L., Xu, Q., Wang, J., Liu, W., Jiang, J., and Meng, Y. (2011). Isolation and degradation ability of the DDT-degrading bacterial strain KK. *Environmental Earth Sciences* 62, 93-99.
- Yabusaki, S. B., Fang, Y., Long, P. E., Resch, C. T., Peacock, A. D., Komlos, J., Jaffe, P. R., Morrison, S. J., Dayvault, R. D., White, D. C., and Anderson, R. T. (2007). Uranium removal from groundwater via in situ biostimulation: Field-scale modeling of transport and biological processes. *J Contam Hydrol* 93, 216-35.
- Yang, D. S., Pennisi, S. V., Son, K., and Kays, S. J. (2009). Screening indoor plants for volatile organic pollutant removal efficiency. *HortScience* 44, 1377-1381.
- Yoo, M. H., Kays, S. J., Son, K. C., and Kwon, Y. J. (2006). Efficacy of indoor plants for the removal of single and mixed volatile organic pollutants and physiological effects of the volatiles on the plants. *Journal of the American Society for Horticultural Science* 131, 452-458.
- Zemankova, K., and Brechler, J. (2010). Emissions of biogenic VOC from forest ecosystems in central Europe: estimation and comparison with anthropogenic emission inventory. *Environ Pollut* 158, 462-9.

Table 2.1. Mechanisms in phytoremediation (adopted from Sheoran et al., 2012)

| Process name        | Mechanism   |
|---------------------|---|
| Phytostabilization  | Plants suppress the migration of contaminants from distribution in water and soil.  |
| Phytoextraction     | Plants uptake and translocate heavy metal into the root or the upper portion of the plants.   |
| Phytovolatilization | Plants absorb elemental forms of metal contaminants (e.g. As, Hg, Se) from the soil, and biologically convert them to gaseous species and release them into atmosphere. |
| Rhizofiltration     | Plants use plant roots or seedling to absorb or adsorb pollutants from aqueous environment.   |
| Rhizodegradation    | Biological treatment of a contaminant by enhanced bacterial and fungal activity in the rhizospheres of plants.  |

Table 2.2. Examples of plants capable of removing volatile organic compounds (VOCs)

| VOCs   | Plants                        | References               |
|--|-------------------------------|--------------------------|
| Benzene and toluene  | <i>Acer campestre</i>         | (Ugrekheldze et al.1997) |
|  | <i>Malus domestica</i>        |                          |
|  | <i>Vitis vinifera</i>         |                          |
|  | <i>Spinacia oleracea</i>      |                          |
| Formaldehyde   | <i>Epipremnum aureum</i>      | (Schmitz et al., 2000)   |
|  | <i>Ficus benjamina</i>        |                          |
| Benzene  | <i>Crasula portulacea</i>     | (Liu et al., 2007)       |
|  | <i>Hydrangea macrophylla</i>  |                          |
|  | <i>Cymbidium 'Golden Elf'</i> |                          |
| Toluene, benzene,<br>trichloroethylene,<br>octane,<br>$\alpha$ -pinene | <i>Hemigraphis alternata</i>  | (Yang et al., 2009)      |
|  | <i>Hedera helix</i>           |                          |
|  | <i>Ficus benjamina</i>        |                          |
|  | <i>Polyscias fruticosa</i>    |                          |
|  | <i>Peperomia clusiifolia</i>  |                          |
|  | <i>Chlorophytum comosum</i>   |                          |
| Benzene  | <i>Howea forsteriana</i>      | (Orwell et al., 2004)    |
|  | <i>Dracaena marginata</i>     |                          |
|  | <i>Epipremnum aureum</i>      |                          |
| Benzene and toluene  | <i>Spathiphyllum wallisii</i> | (Yoo et al., 2006)       |
|  | <i>Cissus rhombifolia</i>     |                          |
|  | <i>Syngonium podophyllum</i>  |                          |

Table 2.3. Biostimulants and their characteristics

| Biostimulants | Characteristics                               | References                 |
|---------------|---|----------------------------|
| Acetate       | Carbon source                                 | (Yabusaki et al., 2007)    |
| Sulfate       | Ability to exchange large numbers of electron | (Dou et al., 2008)         |
| Nitrate       | Require less energy to remove electron        | (Da Silva et al., 2005)    |
| Ethanol       | Carbon source                                 | (Nyman et al., 2007)       |
| Electrodes    | Heavy metal will accumulate on electrode      | (Gregory and Lovley, 2005) |
| Oxygen        | Most energetically favorable                  | (Begley et al., 2012)      |

Table 2.4. Examples of microorganisms isolated from contaminated sites

| Microorganisms             | Chemicals that were degraded  | Reference  |
|----------------------------|---|--|
| <i>Pseudomonas spp</i>     | Benzene, toluene, xylene, hydrocarbons, PCBs, Naphthalene, phenanthrene           | (Cybulski et al., 2003; Di Martino et al., 2012; Kafilzadeh and Pour, 2012; Kapley et al., 1999) |
| <i>Alcaligenes spp</i>     | Halogenated hydrocarbons, polycyclic aromatics, PCBs, DDT                         | (Lal and Khanna, 1996; Xie et al., 2011)   |
| <i>Bacillus spp</i>        | Phenothiazine, fluorine, fluoranthene, dibenzothiophene, phenanthrene, and pyrene | (Syakti et al., 2013)  |
| <i>Corynebacterium spp</i> | Naphthalene, phenanthrene, pyrene   | (Kafilzadeh and Pour, 2012)  |
| <i>Flavobacterium spp</i>  | Dichlorvos  | (Ning et al., 2012)  |
| <i>Azotobacter spp</i>     | Hydrocarbons  | (Gradova et al., 2003)   |
| <i>Rhodococcus spp</i>     | Pyrene, endosulfan  | (Kafilzadeh et al., 2012; Verma et al., 2011)  |
| <i>Mycobacterium spp</i>   | Vinyl chloride, cis-dichloroethene, 1,2-dichloroethane, pyrene                    | (Kafilzadeh et al., 2012; Le and Coleman, 2011)  |
| <i>Nocardia spp</i>        | Pyrene, phenol, hexadecane  | (Kafilzadeh et al., 2012)  |

## CHAPTER 3

# ISOLATION AND IDENTIFICATION OF TOLUENE METABOLIZING BACTERIA FROM RHIZOSPHERES OF TWO INDOOR PLANTS<sup>1</sup>

---

<sup>1</sup> Zhang, H., Pennisi, S.V., Kays, S.J. and M. Y. Habteselassie. Submitted to *Soil, Water, & Air Pollution*, 06/26/2013.

## ABSTRACT

The role of the rhizosphere microbial community in removing volatile organic compounds has not been well investigated. In this study, two species of indoor foliage plants, *Fittonia verschaffeltii* var. *argyroneura*, and *Hoya carnosa* were primed with toluene exposure for two months, followed by isolation and identification of the rhizosphere bacteria that were demonstrated to metabolize toluene. A total of forty-two bacterial isolates were obtained. The number of bacterial isolates was narrowed to twenty three which had banding pattern similarities of 80% or less, using BOX-polymerase chain reaction (PCR) fingerprinting technique. The twenty-three isolates were further characterized by sequencing part of their 16S rDNA after PCR. Their identities were examined using Basic Local Alignment Search Tool (BLAST), resulting in the isolates having the highest sequence similarities (97-100%) to eight known bacteria strains, none of which had been previously reported to be capable of degrading toluene. The bacterial isolates were positive for toluene monooxygenase gene, confirming their ability to metabolize toluene. The isolation and characterization of toluene-metabolizing bacteria corroborates previous speculation that the rhizosphere microbial community contributes to the phytoremediation potential of indoor foliage plants.

## INTRODUCTION

The building industry has encountered greater indoor air quality problems with the advent of more energy-efficient buildings (NRC, 2011). The superior energy efficiency of newer buildings, with substantially reduced air exchange rates, often results in a marked increase in the concentration of indoor air pollutants (Cohen, 1996). Indoor air in cities has been reported to be as much as 100 times more polluted than outdoors (Brown, 1997; Brown et al., 1994; Godish, 1995; Ingrosso, 2002; Zabiegała, 2006). Deterioration of indoor air quality can result in “multiple chemical sensitivity”, “new house syndrome”, and “sick building syndrome” (Ando, 2002; Shinohara et al., 2004) and a cross-section of medical manifestations for those exposed including acute illnesses (e.g., asthma, nausea) and chronic diseases (e.g., cancer, immunologic, neurologic, reproductive, developmental, and respiratory disorders) (Hayashi et al., 2004; Wichmann et al., 2009).

Hundreds of volatile organic compounds (VOCs) have been identified as indoor contaminants (ACGIH, 1995; Won et al., 2005). VOCs are organic compounds classified as: aromatic hydrocarbons (e.g., benzene, toluene, xylene), aliphatic hydrocarbons (e.g., hexane, heptane), halogenated hydrocarbons [e.g., trichloroethylene (TCE), methylene chloride], and terpenes (e.g.,  $\alpha$ -pinene, d-limonene) based on their functional groups (Suh et al., 2000; Wolkoff and Nielsen, 2001). VOCs in the indoor environment are mainly anthropogenic; emission sources include paints, varnishes, furnishings, clothing, cleaning agents, cosmetics, building materials, electronics, and combustion appliances (Jones, 1999; Sterling, 1985). Most VOCs are not acutely toxic, but instead have long-term health effects and could eventually lead to severe diseases such as cancer (e.g., benzene

has been categorized while toluene has been suspected as a carcinogen) (Kirkeskov et al., 2009; Yu and Crump, 1998).

A cross-section of indoor plant species are known to remove VOCs from air (Orwell et al., 2006; Orwell et al., 2004; Wolverton et al., 1989, 1984; Wood et al., 2002; Yang et al., 2009). Over 30 species of predominantly ornamental plants (commonly used in interiorscapes and inside residences) have been studied and screened for their removal capability and efficiency towards VOCs (Yang et al., 2009). Plants absorb VOCs by way of their stomata during normal gas exchange, while some VOCs are also removed by absorption and adsorption to plant surface and soil particles (Wood et al., 2002).

Microorganisms found in the growing media of potted plants are also involved in the removal of VOCs as illustrated by the fact that when the plant(s) are removed from the media, the VOCs continue to decrease (Wolverton et al., 1989; Wood et al., 2002), and plants held in the dark remove VOCs (Orwell et al., 2004; Wolverton et al., 1984; Yoo et al., 2006). Likewise, the addition of selected microbes to the media increases the rate of VOC removal (Chun et al., 2010) and removal efficiency is improved when the plants are continuously exposed to air containing VOCs (Orwell et al., 2006; Wolverton et al., 1989).

The rhizosphere of foliage plants represents a complex and structured ecosystem. Plants excrete carbon into the root zone that stimulates the development of microorganisms in the rhizosphere (Schwab et al., 1998; Krafczyk et al., 1984). A number of soil microorganisms are capable of degrading toxic chemicals when activated by root growth (Cleverland and Yavitt, 1998; Darlington et al., 2000; Wood et al., 2002), however, only few of them have been identified to date. Our current understanding of

rhizosphere biology relative to the removal of VOCs is limited (Guieysse et al., 2008). Here we report the isolation and genetic characterization of toluene metabolizing bacteria from rhizosphere of indoor plants previously reported as being highly efficient in removing volatile organic compounds. Toluene was chosen for this study as a representative VOC because of its ubiquity in indoor environments and its ability to be readily absorbed through the respiratory tract.

## MATERIALS AND METHODS

### *Plant material*

*Hoya carnosa* (L.f.) R.Br. (Wax flower) and *Fittonia verschaffeltii* var. *argyroneura* L., hereby referred to as *F. verschaffeltii* (Nerve plant, Silver-net leaf) were selected for this study due to their documented superior ability to remove VOCs (Table 3.1; Yang et al., 2009). Four plants of each species were obtained from a commercial source, potted up in 10 cm dia pots in Fafard 3B Mix (Canadian Sphagnum peat moss, processed pine bark, perlite, vermiculite, starter nutrients, wetting agent, and dolomitic limestone, Conrad Fafard Inc., Anderson, SC) and placed in a double-polyethylene Quonset-style greenhouse for acclimatization for a period of six weeks at a day time light intensity of  $\sim 100 \mu\text{mol}\cdot\text{m}^{-2}\cdot\text{s}^{-1}$ . The light level was measured at 2 PM under sunny conditions using an LI-190 quantum sensor connected to a hand-held LI-250A light meter (Li-COR Biosciences, Lincoln, NE).

A double layer of aluminum-clad shade cloth was placed over the bench where the plants were grown. The temperature control in the greenhouse was set at 21°C day/18°C night (Wadsworth Systems, Arvada, CO). Plants were fertilized once per week at the

rate of 75 ppm N (24N - 8P -16K) in accordance to recommended fertilization regime for acclimatized indoor plants (Conover and Poole, 1981). Media fertility levels were monitored using the pour-through method (Yeager, et al., 1997). Distilled water (50 mL) was poured into each pot and allowed to drain; leachate was collected and pH and electrical conductivity (EC) were analyzed (Agrimeter AG-6, Myron L Co., Carlsbad, CA). Medium fertility levels were found to be within appropriate levels on all testing dates (EC: 1.3 to 1.6 dS·m<sup>-1</sup>; pH: 5.5-6.5) (Reed, 1996).

Tissue and media samples were sent to MicroMacro Labs (Athens, GA) for analysis at the end of the greenhouse acclimatization period. Macro- and micronutrient tissue levels were found to be within appropriate ranges, based on general recommendations for foliage plants (Mills and Jones, 1996).

After six weeks, plants were moved to a laboratory environment at room temperature (20-22°C) under approximately 10 μmol·m<sup>-2</sup>·s<sup>-1</sup> irradiance provided by fluorescent lamps and a 12 hr cycle of light and dark. Plants were irrigated as needed but no fertilizer solution was applied. To encourage the proliferation of toluene-degrading bacteria in the rhizosphere, the experimental plants were exposed to toluene in airtight desiccators continuously for two months (Chen, et al, 2010). The toluene (80 uL) was placed in a 1.5 mL micro-centrifuge tube and suspended inside the incubator and replenished daily. Toluene was chosen as representative VOC because of its reported prevalence in indoor air (Dawson and McAlary, 2009; Kostianen, 1995; Wolkoff and Nielsen, 2001).

### *Extraction and isolation of toluene-degrading microorganisms*

Rhizospheres were destructively sampled after two months of exposure to toluene. From each rhizosphere sample two 10 g subsamples were used to prepare rhizosphere suspensions in 0.1% of sodium pyrophosphate (Baker Analyzed Reagent, J.T.Baker®, MG Scientific, Pleasant Prairie, WI). The suspensions were shaken using a rotary shaker at 150 rpm for 1.5 h (incubating orbital shaker, VWR, Radnor, PA) to dislodge the cells from the plant roots and potting mix. The suspensions were used to prepare serial dilutions with 1X phosphatase buffer saline (PBS). The suspensions were plated on mineral salt medium agar (MSM) containing  $K_2HPO_4$  (0.01mol/L),  $NaH_2PO_4$  (0.003mol/L),  $(NH_4)_2SO_4$  (0.01mol/L),  $MgSO_4$  (0.001mol/L),  $Ca(NO_3)_2$  (0.0001mol/L), and  $Fe(NO_3)_3$  (0.00001mol/L). Trace minerals were included:  $MnSO_4$  (0.001mmol/L),  $ZnSO_4$  (0.001mmol/L),  $CuSO_4$  (0.001mmol/L),  $NiSO_4$  (0.0001mmol/L),  $CoSO_4$  (0.0001mmol/L), and  $Na_2MoO_4$  (0.0001mmol/L) (Baker Analyzed Reagent, J.T.Baker®, MG Scientific, Pleasant Prairie, WI).

The plates were placed in a solvent-resistant mason jars in which a polytetrafluoroethylene (PTFE) taped microcentrifuge tube containing 100 ul of toluene was suspended from above. The toluene acted as the sole source of carbon and energy for any heterotrophic microbial growth on the plates, apart from the substrates that could potentially be carried over from the potting mix. However, due to the dilution, the transfer of substrate was likely minimal. The mason jars were incubated at 30°C in darkness and continuously monitored for growth (Cleveland and Yavitt, 1998). Well-isolated colonies that exhibited growth were removed from the plates and streaked on MSM agar with toluene as the sole source of carbon and energy. The process of screening

for bacteria that can degrade toluene and re-streaking them on MSM agar was repeated until pure cultures of microorganisms were obtained. This process also facilitated eliminating microorganisms that might have grown on the first set of plates due to transfer of substrates carried over from the soil suspensions instead of using toluene.

#### *Identification of microflora isolates*

Once the microbial colonies were isolated, they were inoculated into a liquid mineral salt medium (LMSM) for further characterization as follows. Colonies were aseptically inoculated into 250 mL flask containing 100 mL LMSM. A micro-centrifuge tube containing 100 uL of toluene was suspended from the top of the flask to serve as the sole carbon source for the inoculants. The flasks were incubated at 30°C and monitored over time for evidence of growth, which was indicated by an increase in turbidity (Cleveland and Yavitt, 1998). The cultures were harvested by centrifuging at 10,000 rpm for 10 min and the cells were resuspended with 1X PBS. The genomic DNA of the cells was extracted by using the DNAzol kit (Genomic DNA isolation reagent, Molecular Research Center, Inc., Cincinnati, OH). DNA concentration was determined with Nanodrop (Thermo Science, Waltham, MA).

The number of isolates considered for detailed characterization was narrowed by comparing the banding patterns of the isolates with BOX-Polymerase Chain Reaction (BOX-PCR) with the BOX A1R primer (5'-CTA CGG CAA GGC GAC GCT GAC G-3') (Rademaker et al., 2004). All primers used in this study were synthesized at the Georgia Genomics Facility (<http://dna.uga.edu/>). The BOX-PCR conditions were as follows: initial denaturation of 4 minutes at 94°C for one cycle followed by 29 cycles of 3 seconds at 94°C, 45 seconds at 92°C, 1 minute at 50°C, and 6 minutes at 65°C

(Rademaker et al., 2004). Fifty ng of genomic DNA were used for the BOX-PCR. The electrophoresis of the BOX-PCR reaction products was performed on 2% high-resolution agarose gel (Certified Molecular Biology Agarose, BIO-RAD Laboratories, Inc., Hercules, CA) at 4°C and 70 V for 13 h. The gel was stained with ethidium bromide solution (5 ng/L) (BIO-RAD laboratories, Inc., Hercules, CA) for 30 min, viewed under UV light (high performance ultraviolet transilluminator, UVP, Upland, CA), and photographed with a digital CCD camera (Gel Logic 100 imaging system, Kodak, Rochester, NY). BOX-PCR banding pattern analysis was performed with GelCompar II of BioNumerics (Applied Maths, Austin, TX) to determine the percent similarity among the isolates.

After narrowing the number of isolates to be further characterized with BOX-PCR, the genomic DNAs of the screened isolates were subjected to PCR that targeted sections of their 16S rDNA using the universal bacterial primer pair 968F (5'-AAC GCG AAG AAC CTT AC-3') and 1401R (5'-CGG TGT GTA CAA GAC CC-3') (Felske et al., 1996). The PCR conditions were: initial denaturation of 2 min at 94°C followed by 35 cycles of 1 min of 94°C, 1 min of 58.5°C, and 2 min of 72°C. The final extension was 10 min at 72°C (Felske et al., 1996). All of the PCR reactions were conducted with a BIO-RAD MyCycler thermocycler (BIO-RAD laboratories, Inc., Hercules, CA). The PCR amplicons (410 bp) were purified with a PCR purification kit (Wizard PCR Preps DNA Purification System, Promega, Madison, WI) and were sequenced with the forward primer 968F at the Georgia Genomics Facility (<http://dna.uga.edu/>). The sequence data were compared against the existing sequences in the GenBank database of the National Center for Biotechnology Information (NCBI, <http://blast.ncbi.nlm.nih.gov/>). All the

sequences were first aligned and the subsection of the alignment from the center (224 bp) was used for construction of phylogenetic trees in Clustal Omega (European Bioinformatics Institute, <http://www.ebi.ac.uk/Tools/msa/clustalo/>).

Eight unique isolates, based on their percent sequence similarities with known bacterial strains, were subsequently tested for the presence of toluene monooxygenase gene (one of the genes involved in microbial toluene metabolism) by using a PCR assay with the RMO-F and RMO-R primer pair as described in Baldwin et al. (2003). The PCR products were run in 1.5% agarose gel. The procedure for genomic DNA extraction, electrophoresis conditions and set-up for taking gel images were as described in the section above.

## RESULTS

A total of forty two isolates were screened based on their ability to use toluene as a sole carbon and energy source (Figure 3.1). Twelve of the isolates were from the rhizosphere of the *H. carnosus* and the remaining thirty isolates were from the rhizosphere of *F. verschaffeltii*. The BOX-PCR banding patterns of the isolates revealed that only twenty three had 80% or less similarity, which was used as a cut-off point for selecting the most dissimilar isolates for further characterization (Figure 3.1). The remaining twenty three isolates were identified based on their partial 16S rDNA sequence similarity against known bacterial strains in the Genbank database (Table 3.2).

The twenty three isolates had maximum percent sequence similarities with eight known bacterial strains. Their percent sequence similarities ranged between 97 to 100% to the known strains (Table 3.2). Approximately 52% of the isolates had the highest

percent sequence similarity with *Microbacterium aerolatum* strain V-73 while thirty five percent of the isolates were most similar to *Paenibacillus lautus* strain JCM9073, *Paenibacillus tundrae* strain Ab10b, *Paenibacillus barcinonensis* strain BP-23, and *Paenibacillus taichungensis* strain BCRC17757 (Table 3.3). The remaining 13% of the isolates had maximum sequence similarities with the other seven bacterial strains, *Rhodococcus marinonascens* strain DSM43752, *Microbacterium kribbense* strain MSL04, and *Paenibacillus favisporus* strain GMP01 (Tables 3.2, 3.3).

One representative isolate from each of the eight groups of isolates (Table 3.3) was selected for testing for presence of the toluene monooxygenase gene. All the selected isolates were positive, indicating the presence of the gene in them, confirming their ability to metabolize toluene (Figure 3.2)

Of the twenty three isolates that were identified after sequencing, five (22%) were from *H. carnosus* and eighteen (78%) from *F. verschaffeltii* (Table 3.3). Eleven of the isolates (61%) from *F. verschaffeltii* were most similar to the bacterial strain *Microbacterium aerolatum* V-73 while only one of the isolates (20%) from *H. carnosus* was most similar to this bacterial strain. Most of the isolates (40%) from *H. carnosus* were most similar to *Paenibacillus lautus* strain JCM9073. Overall, isolates obtained from *F. verschaffeltii* were more abundant and diverse than isolates obtained from *H. carnosus*.

Comparison of the isolates based on their sequence similarities (Table 3.4; Figure 3.3) indicated that isolates 4, 5, 14, 15, 16, 17, 18, 32 and 42 were identical (i.e., 100% sequence similarities). Except for isolate 14 that originated from the rhizosphere of *H. carnosus*, the rest were obtained from *F. verschaffeltii* (Table 3.2). Isolates 2 and 30, isolates 20 and 23, and isolates 33 and 40 were also identical to each other. Except for

isolates 2 the rest were obtained from *F. verschaffeltii*. Isolates that were obtained from *H. carnososa* (1, 30, 37 and 39) had high sequence similarities among each other (ranging between 92 to 98%) except isolate 14 that had identical sequence similarity with other four isolates (mentioned above) obtained from *F. verschaffeltii* (Table 3.4).

As indicated in the phylogenetic tree of the isolates based on their partial 16S rDNA sequence (Figure 3.3), the isolates generally grouped into two clusters. All the isolates from *H. carnososa* except one (isolate 14) fell in the first cluster of the tree while the isolates from *F. verschaffeltii* were spread between the two clusters. Approximately 44% of the isolates in cluster 1 were from *H. carnososa* while the remaining 55% of the isolates were from *F. verschaffeltii*. In the second cluster, 97% of the isolates were from *F. verschaffeltii* whereas only 7% (one isolate) in this cluster was from *H. carnososa*.

## DISCUSSION

The ability of indoor plants to remove VOCs has been well-documented (Kays, 2011; Kim and Lee, 2008; Liu et al., 2007). Apart from the aboveground parts of the plants that are involved in VOC removal by absorption through the stomata and cuticle (Kim, et al, 2008; Kondo et al, 1995; Yoo et al., 2006) , a number of studies have indicated that the plant root zone is equally if not more important in the removal process. This was demonstrated by either keeping the plants in the dark (when stomata are closed) (Orwell et al., 2004) or removing the aboveground parts of the plants (Kim et al., 2008). Both these practices led to a decrease in VOC concentrations, leading to the conclusion that microorganisms in the root zone (rhizosphere) were responsible for the VOCs removal. Even though the potting media without any plants or microorganisms (i.e.,

sterilized) have been shown to remove VOC via physical adsorption, this mechanism is short-lived and of limited potential, reiterating the role of microorganisms in the media in removing VOCs (Kim et al., 2008; Wood et al, 2002).

The rhizosphere microbial community probably plays a more important role in this regard as compared to microbial community in the bulk soil/media that is not directly affected by the plant roots. This assumption is based on a number of previous studies which have demonstrated that rhizosphere microorganisms were more active and diverse than those found in the bulk soil due to the carbon input (exudates) from the plant roots (Kuiper et al., 2004; Wenzel, 2009). A number of rhizosphere bacteria have been used to remediate soils from a variety of contaminants where field crops were grown (McGuinness and Dowling, 2009; Ryan et al., 2008).

Despite the numerous studies that examined the role of indoor plants in removing VOCs, there is virtually no information on the isolation and identification of microorganisms from the rhizosphere or growing media. The studies cited above indirectly examined the role of microorganisms. Information on microbial identity is essential for acquiring a more comprehensive understanding of the mechanisms by which indoor plant remove VOCs, in addition to identifying microorganisms that are efficient at VOCs removal. A functional system of removing VOCs from indoor air may include the introduction of purified, highly efficient VOCs-metabolizing microflora into the growth media to enhance remediation potential of indoor air via biological means. Our study addressed this knowledge gap by isolating bacteria from the rhizospheres of two indoor plants and identifying them for future inoculation or re-inoculation. We have isolated and

identified several bacterial isolates whose partial 16S rDNA sequences were most similar to eight known bacterial strains.

The isolates that were *Microbacterium aerolatum* strain V-73 like were the most common (i.e., 11 of the isolates from *F. verschaffeltii* and 1 from *H. carnosus* were most similar to this strain). This strain was first isolated from the air in Austria (Zlamala et al., 2002). Our literature search did not find studies reporting the presence of this strain in potting media or soils. This could indicate two plausible explanations: the isolates that were most similar to this strain either originated from the air during culturing or from the rhizosphere samples that could have originated from the air during gaseous exchange with the head space. A more plausible explanation is that the Austrian sample actually originated from the soil and was transferred to the air by wind or rain. Either way, the isolates' ability to metabolize toluene would contribute to the plants' ability to remove the chemical through its interaction with the plant both belowground (rhizosphere) and aboveground (phyllosphere). *Microbacterium aerolatum* is heterotrophic (i.e., needs organic source of carbon and energy such as toluene), meaning it could not use the carbon dioxide in the atmosphere as a carbon source (Zlamala et al., 2002).

The second bacterial strain that was most similar to isolates from both plants was *Paenibacillus tundrae* strain Ab10b. This strain was originally isolated from a tundra (high altitude) soil as one of eight xylene-degrading bacteria (Nelson et al., 2009). Even though it was originally isolated from a low-temperature soil, the same study reported that its optimum growth temperature was 27°C and it was capable of growing and reproducing in warmer environments, which would explain its isolation from the rhizosphere samples. The bacterium has also a wide range of pH optima values (5.2 -8.8)

(Nelson et al., 2009), indicating its ability to adapt and grow under a variety of environmental conditions. The fact that it was originally isolated as xylene-degrading bacterium supports our finding that it metabolizes toluene, which is structurally similar to xylene as both are aromatic hydrocarbons based on a benzene ring structure. This strain is also a heterotroph (Nelson et al., 2009).

The remainder of the isolates were obtained from only one of the plants and were most similar to other *Paenibacillus*, *Microbacterium* or *Rhodococcus* spp. *Paenibacillus* species are well known for their ability to degrade complex organic molecules and are ubiquitous in the environment (Nelson et al., 2009; Park et al., 2007; Rivas et al., 2006). This probably explains why a number of the isolates from the rhizospheres of the two plants had the highest sequence similarity with several *Paenibacillus* strains. Two strains from *F. verschaffeltii* were most similar to *Microbacterium kribbense* strain MSL04 and *Rhodococcus marinonascens* strain DSM43752. The *Microbacterium kribbense* strain MSL04 was first isolated from an agricultural soil in the South Korea and is capable of metabolizing a number of organic substrates, including phenyl acetate that has an aromatic structure, similar to toluene (Dastager et al., 2008). To our knowledge, this strain has not been tested for its capability to metabolize toluene before as far as we can tell. *Rhodococcus marinonascens* strain DSM43752 was isolated for the first time from marine sediment (Helmke and Wayland, 1984). Based on its growth requirements, its presence in the rhizosphere samples is possible. We have not, however, been able to locate any studies that link this strain to the degradation of toluene or chemicals with similar structure and properties.

It was not a surprise that the isolates from the rhizospheres of the two indoor plants were largely different except for a few common isolates. The rhizosphere microbial community composition is strongly affected by the plant type, which determines the quality and quantity of exudates (Grayston et al., 1998; Macdonald et al., 2004). In this study, we obtained fewer and less unique isolates from *H.carnosa* than *F. verschaffeltii* even though comparable rhizosphere samples were collected from both plants. Both plants were also growing in identical potting media and exposed to toluene for the same period of time. This would suggest that *F. verschaffeltii* may harbor a more effective rhizosphere bacterial community as compared to *H. carnosa* with regards to toluene metabolism. The toluene removal efficiency ( $\mu\text{g}\cdot\text{m}^{-3}\cdot\text{m}^{-2}\cdot\text{h}^{-1}$ ) of *F. verschaffeltii* is actually lower than that of *H. carnosa* (Table 3.1; Yang et al., 2009). However *F. verschaffeltii* is faster-growing compared to *H. carnosa* (Conover and Poole, 1981), thus achieving a larger size, which may result in a higher quantity of exudates in its rhizosphere.

The ultimate goal of identifying the bacteria responsible for toluene degradation is to introduce the microbial isolates to rhizospheres of plant species, which may not harbor such microflora, and to re-introduce them into the rhizospheres of indoor plants where they already exist, enhancing the plant's capacity to remove toluene from indoor air, in effect facilitating remediation via biological means. The concept of inoculating microorganisms into contaminated sites to facilitate degradation of pollutants, also known as bio-augmentation, is widely practiced in outdoor environments. Microorganisms had been introduced to ground waters (e.g., Ellis et al, 2000; Smith et al., 2005; Tani et al., 2002) and soils (Fantroussi and Agathos, 2005; Planklang and

Reungsand, 2011; Shapir and Mandelbaum, 1997; Strong et al., 2000) contaminated with various chemicals to enhance and speed-up degradation of the contaminants.

Bioaugmentation has been successful in general, however, in practice its effectiveness has been commonly hampered due to the low survival rate of the inoculated microorganisms as a result of low nutrient availability and adverse and fluctuating conditions in the outside environment (e.g., temperature, moisture, etc.) (Motoyama et al., 2001; van Veen et al., 1997). With indoor settings, however, the environmental conditions are usually strictly controlled and the plants are supplied with sufficient water and nutrients. As a result, bio-augmentation would potentially have a higher rate of success in improving indoor air quality using living plants. This assumption would be tested in future work, whereby microbial isolates from this study will be introduced to rhizospheres of other species of indoor plants in an effort to enhance their potential in removing toluene.

## REFERENCES

- ACGIH. 1995. Threshold limit values for chemical substances and physical agents and biological exposure indices. American Conference of Government and Industrial Hygienists. 1994-5, Cincinnati, Ohio.
- Ando, M. 2002. Indoor air and human health. Sick-house syndrome and multiple chemical sensitivity. *Kokuritsu Iyakuhiin Shokuhin Eisei Kenkyusho Hokoku* 120:6-38.
- Baldwin, B.R., C.H. Nakatsu and L. Nies. 2003. Detection and enumeration of aromatic oxygenase gene by multiplex and real-time PCR. *Appl. Environ. Microbiol.* 69:3350-3358.
- Brown, S. 1997. Volatile organic compounds in indoor air: sources and control. *Chem. Australia* 64:10-13.
- Brown, S.K., M.R. Sim, M.J. Abramson, and C.N. Gray. 1994. Concentrations of volatile organic compounds in indoor air - a review. *Indoor Air* 4:123-134.
- Chen, L., H. Yurimoto, K. Li, I. Orita, M. Akita, N. Kato, Y. Sakai, and K. Izui. 2010. Assimilation of formaldehyde in transgenic plants due to the introduction of the bacterial ribulose monophosphate pathway genes. *Biosci. Biotechnol. Biochem.* 74:627-635.
- Cleveland, C.C., and J.B. Yavitt. 1998. Microbial consumption of atmospheric isoprene in a temperate forest soil. *Appl. Environ. Microbiol.* 6:172-177.
- Chun, S.C., M.H. Yoo, Y.S. Moon, M.H. Shin, K.C. Son, I.M. Chung, and S.J. Kays. 2010. Effect of bacterial population from rhizosphere of various foliage plants on

- removal of indoor volatile organic compounds. *Kor. J. Hort. Sci. Technol.* 28:476-483.
- Cohen, Y. 1996. Volatile organic compounds in the environment: A multimedia perspective. *Volatile organic compounds in the environment*, p. 7-32. In: W. Wang, J. Schnoor, and J. Doi (eds.). ASTM STP 1261. American Society for Testing and Materials.
- Conover, C.A., and R.T. Poole. 1981. Environmental Factors, p. 269-283. In: J. Joiner (ed.). *Foliage Plant Production*. Prentice-Hall, Englewood Cliffs, NJ.
- Darlington, A., M. Chan, D. Malloch, C. Pilger, and M.A. Dixon. 2000. The biofiltration of indoor air: Implications for air quality. *Indoor Air* 10:39-46.
- Dastager, S.G., J. Lee, Y. Ju, D. Park, and C. Kim. 2008. *Microbacterium kribbense* spp. Nov., isolated from soil. *Intl. J. Syst. Evol. Microbiol.* 58:2536-2540.
- Dawson, H.E., and T. McAlary. 2009. A Compilation of Statistics for VOCs from Post-1990 Indoor Air Concentration Studies in North American Residences Unaffected by Subsurface Vapor Intrusion. *Ground Water Monitoring Remediation* 29:60-69.
- Ellis, D.E., E.J. Lutz, J.M. Odom, R.J. Buchanan, C.L. Bartlett, M.D. Lee, M.R. Harkness, and K.A. Deweerdt. 2000. Bio-augmentation for accelerated in situ anaerobic bioremediation. *Environ. Sci. Technol.* 34:2254-2260.
- Fantroussi, S.E., and S.N. Agathos. 2005. Is bio-augmentation a feasible strategy for pollutant removal and site remediation? *Current Opinion Microbiol.* 8:268-275.
- Felske A., B. Engelen., U. Nübel, and H. Backhaus. 1996. Direct ribosome isolation from soil to extract bacterial rRNA for community analysis. *Appl. Environ. Microbiol.* 62:4162-4167.

- Guieysse, B., C. Hort, V. Platel, R. Munoz, M. Ondarts, and S. Revah. 2008. Biological treatment of indoor air for VOC removal: Potential and challenges. *Biotech. Advances* 26:398-410.
- Godish, T. 1995. *Sick building: definition, diagnosis, and mitigation*. Lewis Publishers, Boca Raton, FL.
- Grayston, S.J., S.Q. Wang, C.D. Campbell, and A.C. Edwards. 1998. Selective influence of plant species on microbial diversity in the rhizosphere. *Soil Biol. Biochem.* 30:369-378.
- Hayashi, H., N. Kunugita, K. Arashidani, H. Fujimaki, and M. Ichikawa. 2004. Long-term exposure to low levels of formaldehyde increases the number of tyrosine hydroxylase-immunopositive periglomerular cells in mouse main olfactory bulb. *Brain Res.* 1007:192-197.
- Helmke, E., and H. Weyland, 1984. *Rhodococcus marinonascens* sp. Nov., an actinomycete from the sea. *Int. J. Syst. Bacteriol.* 34:127-138.
- Inghosso G. 2002. Free radical chemistry and its concern with indoor air quality: an open problem. *Microchemistry J.* 73:221-236.
- Jones, A.P. 1999. Indoor air quality and health. *Atmos. Environ.* 33: 4535-4564.
- Kays, S.J. 2011. Phytoremediation of indoor air – Current state of the art, p. 3-21. In: K.J. Kim (ed.). *The value creation of plants for future urban agriculture*. National Institute of Horticulture and Herbal Sciences, RDA, Suwon, Korea.
- Kim, K.J., and D.W. Lee. 2008. Efficiency of volatile formaldehyde removal of orchids as affected by species and crassulacean acid metabolism (CAM) nature. *Hort. Environ. Biotechnol.* 49:132-137.

- Kim, K.J., M.J. Kil, J.S. Song, E.H. Yoo, K.C. Son, and S.J. Kays. 2008. Efficiency of volatile formaldehyde removal by indoor plants: contribution of aerial plant parts versus the root zone. *J. Am. Soc. Hort. Sci.* 133:521-526.
- Kirkeskov, L., T. Witterseh, L.W. Funch, E. Kristiansen, L. Mølhave, M.K. Hansen, B.B. Knudsen. 2009. Health evaluation of volatile organic compound (VOC) emission from exotic wood products. *Indoor Air* 19:45-57.
- Kondo, T., K. Hasegawa, R. Uchida, M. Onishi, A. Mizukami, and K. Omasa. 1995. Absorption of formaldehyde by oleander (*Nerium indicum*). *Environ. Sci. Technol.* 29:2901-2903.
- Kostiainen, R., 1995. Volatile organic compounds in the indoor air of normal and sick houses. *Atmos. Environ.* 29:693-702.
- Krafczyk, I., G. Trolldenier, and H. Beringer, 1984. Soluble root exudates of maize influence of potassium supply and rhizosphere microorganisms. *Soil Biol. Biochem.* 16:315-322.
- Kuiper, I., E.L. Lagendijk, G.V. Bloemberg, and J.J. Lugtenberg. 2004. Rhizoremediation: A beneficial plant-microbe interaction. *Mol. Plant Microbiol. Inter.* 1:6-15.
- Liu, Y.J., Y.J. Mu, Y.G. Zhu, H. Ding, and N.C. Arens. 2007. Which ornamental plant species effectively remove benzene from indoor air? *Atmos. Environ.* 41:650-654.
- Macdonald, L.M., E. Paterson, L.A. Dawson, and A.J.S. MacDonald. 2004. Short-term effects of defoliation on the soil microbial community associated with two contrasting *Lolium perenne* cultivars. *Soil Biol. Biochem.* 36:489-489.

- McGuinness, M., and D. Dowling, 2009. Plant-associated bacterial degradation of toxic organic compounds in soil. *Int. J. Environ. Res. Public Health* 6:2226-2247.
- Mills, H.A. and J.B. Jones, Jr. 1996. *Plant Analysis Handbook II*. MicroMacro Publishing, Athens, GA.
- Motoyama, T., K. Kadokura, S. Tatsusawa, T. Arie, and I. Yamaguchi, 2001. Application of plant-microbe systems to bioremediation. *RIKEN Reviews* 42:35-38.
- Nelson, D.M., A.J. Glawe, D.P. Labeda, I.K.O Cann, and R.I. Mackie. 2009. *Paenibacillus tundrae* sp. nov. and *Paenibacillus xylanexedens* sp. nov., psychrotolerant, xylan-degrading bacteria from Alaskan tundra. *Int. J. Syst. Evol. Microbiol.* 59:1708-1714.
- National Research Council. 2011. *Climate Change, the Indoor Environment, and Health*. The National Academies Press, Washington, DC.
- Orwell, R., R. Wood, J. Tarran, F. Torpy and M.D. Burchett. 2004. Removal of Benzene by the Indoor Plant/Substrate Microcosm and Implications for Air Quality. *Water Air Soil Pollution* 157:193-207.
- Orwell, R., R. Wood, M. Burchett, J. Tarran, and F. Torpy. 2006. The Potted-Plant Microcosm Substantially Reduces Indoor Air VOC Pollution: II. Laboratory Study. *Water Air Soil Pollution* 177:59-80.
- Park, M.J., H.B. Kim, D.S. An, H.C. Yang, S.T. Oh, J.J. Chung, and D.C. Yang. 2007. *Paenibacillus soli* sp. Nov., a xylanolytic bacterium isolated from soil. *Int. J. Syst. Evol. Microbiol.* 57:146-150.
- Plangklang, P., and A. Reungsand. 2011. Bioaugmentation of carbofuran residues in soil by *Burkholderia cepacia* PCL3: A small-scale field study. *Int. Biodeter.*

Biodegrad. 65:902-905.

- Rademaker, J.L., R.J. Louws, J. Versalovic, and F.J. Bruijn. 2004. Characterization of the diversity of ecologically important microbes by rep-PCR genomic fingerprinting, p. 611-643. In: Kowalchuk, G.A. *et al.* (eds.) *Molecular Microbial Ecology Manual*. Vol. 1. Luwer Academic Publishers, Boston, MA.
- Reed, D.W. 1996. *A grower's guide to water, media, and nutrition for greenhouse crops*. Ball, Batavia, IL.
- Rivas, R., P. Garcia-Fratile, P.F. Mateos, E. Martinez-Molina, and E. Velazquez. 2006. *Paenibacillus cellulosilyticus* sp. Nov., a cellulolytic and xylanolytic bacterium isolated from the bract phyllosphere of phoenix dactylifera. *Int. J. Syst. Evol. Microbiol.* 56:2777-2781.
- Ryan, R.P., K. Germaine, A. Franks, D.J. Ryan, and D.N. Dowling. 2008. Bacterial endophytes: recent developments and applications. *FEMS Microbiol. Ecol.* 278:1-9.
- Schwab, A.P., A.A. Al-Assi, and M.K. Banks. 1998. Adsorption of naphthalene onto plant roots. *J. Environ. Quality* 27:220-224.
- Shapir, N. and R.T. Mandelbaum. 1997. Atrazine degradation in subsurface soil by indigenous and introduced microorganisms. *J. Agric. Food Chem.* 45:4481-4486.
- Shinohara, N., A. Mizukoshi, and Y. Yanagisawa. 2004. Identification of responsible volatile chemicals that induce hypersensitive reactions to multiple chemical sensitivity patients. *J. Exposure Anal. Environ. Epidemiol.* 14:84-91.
- Smith, A.E., K. Hristova, I. Wood, D.M. Mackay, E. Lory, D. Lorenzana, and K.M. Scow. 2005. Comparison of biostimulation versus bioaugmentation with bacterial

- strain PM1 for treatment of groundwater contaminated with methyl tertiary butyl ether (MTBE). *Environ. Health Perspective* 113:317-322.
- Sterling, D.A. 1985. Indoor Air and Human Health, p. 387. In: R.B. Gammage, S.B. Kaye, and V.A. Jacobs (eds.). *Volatile Organic Compounds in Indoor Air: An Overview of Sources, Concentrations, and Health Effects*. Lewis Publishers, Inc., New York.
- Strong, L.C., H. McTavish, M.J. Sadowsky, and L.P. Wackett 2000. Field-scale remediation of atrazine-contaminated soil using recombinant *Escherichia coli* expressing atrazine chlorohydrolase. *Environ. Microbiol.* 2:91-98.
- Suh, H-H., T. Baiadon, J. Vallanno, and J.D. Spellgler. 2000. Criteria air pollutants and toxic air pollutants. *Environ. Health Perspective* 108:625-633.
- Tani, K., M. Muneta, K. Nakamura, K. Shibuya, and M. Nasu. 2002. Monitoring of *Ralstonia eutropha* KT1 in groundwater in an experimental bio-augmentation field by in situ PCR. *Appl. Environ. Microbiol.* 68:412-416.
- van Veen, J.A., L.S. van Overbeek, and J.D. van Elsas. 1997. Fate and activity of microorganisms introduced into soil. *Microbiol. Mol. Biol. Rev.* 61:121-135.
- Wenzel, W.W. 2009 Rhizosphere processes and management in plant-assisted bioremediation (phytoremediation) of soils. *Plant Soil* 321:385-408.
- Wichmann, F.A., A. Muller, L.w. Busi, N. Cianni, L. Massolo, U. Schlink, A. Porta and P.D. Sly 2009. Increased asthma and respiratory symptoms in children exposed to petrochemical pollution. *J. Allergy Clin. Immunol.* 123:632-638.
- Wolkoff, P., and G.D Nielsen. 2001. Organic compounds in indoor air-Their relevance for perceived indoor air quality. *Atm. Environ.* 35: 4407-4417.

- Wolverton, B.C., A. Johnson, and K. Bounds. 1989. Interior landscape plants for indoor air pollution abatement. Final Report. NASA, Stennis Space Center, MS.
- Wolverton, B.C., E.A. Watkins, Jr., and R.C. McDonald. 1984. Foliage plants for removing indoor air pollutants from energy-efficient homes. *Econ. Bot.* 38, 224-228.
- Wood, R.A., R.L. Orwell, J. Tarran, F. Torpy, and M. Burchett. 2002. Potted-plant/growth media interactions and capacities for removal of volatiles from indoor air. *Hort. Sci. Biotechnol.* 77:120-129.
- Won, D., E. Lusztyk, and C.Y. Shaw. 2005. Target VOC list. Final Report. National Research Council Canada, Ottawa, Ontario.
- Yang, D.S., S.V. Pennisi, K.C. Son, and S. Kays. 2009. Screening Indoor Plants for Volatile Organic Pollutant Removal Efficiency. *HortScience* 44:1377-1381.
- Yeager, T., C. Gilliam, T. Bilderback, D. Fare, A. Niemiera, and K. Tilt. 1997. Best management practices: Guide for producing container-grown plants. Southern Nurserymen's Association, Marietta, GA.
- Yoo, M.H., Y.J. Kwon, K.C. Son, and S.J. Kays. 2006. Efficacy of indoor plants for the removal of single and mixed volatile organic pollutants and physiological effects of the volatiles on the plants. *J. Amer. Soc. Hort. Sci.* 131:452-458.
- Yu, C., and D. Crump. 1998. A review of the emission of VOCs from polymeric materials used in buildings. *Building and Environ.* 33:357-374.
- Zabiegała, B. 2006. Organic compounds in indoor environments. *Polish J. Environ. Stud.* 15:383-393.

Zlamala, C., P. Schumann, P. Kampfer, M. Valens, R. Rossello-Mora, W. Lubitz, and H. Busse. 2002. *Microbacterium aerolatum* sp. nov., isolated from the air in the 'Virgilkapelle' in Vienna. *Intr. J. Syst. Evol. Microbiol.* 52:1229-1234.

Table 3.1. Leaf area and toluene removal efficiency of *Hoya carnososa* and *Fittonia verschaffeltii* var. *argyroneura* (Source: Yang et al., 2009)

| Plant species   | Leaf area<br>(cm <sup>2</sup> ·plant <sup>-1</sup> ) | Toluene removal efficiency<br>(µg·m <sup>-3</sup> ·m <sup>-2</sup> ·h <sup>-1</sup> ) |
|---|--|---|
| <i>Hoya carnososa</i>                                     | 452±51   | 5.81 ± 0.67   |
| <i>Fittonia verschaffeltii</i> var.<br><i>argyroneura</i> | 660±45   | 5.09 ± 0.23   |

Table 3.2. Sequence similarities of the isolates against known bacterial strains based on their partial 16S rDNA sequence data.

| No. | Isolates ID | Bacterial strain with which the isolate had the maximum sequence similarity | Maximum % similarity | Source         |
|-----|-------------|---|----------------------|----------------|
| 1   | 1           | <i>Paenibacillus lautus</i> strain JCM 9073                                 | 99                   | H <sup>a</sup> |
| 2   | 2           | <i>Paenibacillus tundrae</i> strain Ab10b                                   | 100                  | H              |
| 3   | 4           | <i>Microbacterium aerolatum</i> strain V-73                                 | 99                   | F <sup>b</sup> |
| 4   | 5           | <i>Microbacterium aerolatum</i> strain V-73                                 | 99                   | F              |
| 5   | 10          | <i>Rhodococcus marinonascens</i> strain DSM 43752                           | 100                  | F              |
| 6   | 14          | <i>Microbacterium aerolatum</i> strain V-73                                 | 99                   | H              |
| 7   | 15          | <i>Microbacterium aerolatum</i> strain V-73                                 | 99                   | F              |
| 8   | 16          | <i>Microbacterium aerolatum</i> strain V-73                                 | 99                   | F              |
| 9   | 17          | <i>Microbacterium aerolatum</i> strain V-73                                 | 99                   | F              |
| 10  | 18          | <i>Microbacterium aerolatum</i> strain V-73                                 | 99                   | F              |
| 11  | 19          | <i>Microbacterium aerolatum</i> strain V-73                                 | 99                   | F              |
| 12  | 20          | <i>Paenibacillus taichungensis</i> strain BCRC 17757                        | 99                   | F              |
| 13  | 23          | <i>Paenibacillus taichungensis</i> strain BCRC 17757                        | 99                   | F              |
| 14  | 24          | <i>Microbacterium kribbense</i> strain MSL 04                               | 97                   | F              |
| 15  | 25          | <i>Microbacterium aerolatum</i> strain V-73                                 | 97                   | F              |
| 16  | 30          | <i>Paenibacillus tundrae</i> strain Ab10b                                   | 100                  | F              |
| 17  | 32          | <i>Microbacterium aerolatum</i> strain V-73                                 | 99                   | F              |
| 18  | 33          | <i>Paenibacillus barcinonensis</i> strain BP-23                             | 100                  | F              |
| 19  | 37          | <i>Paenibacillus favisporus</i> Stain GMP01                                 | 99                   | H              |
| 20  | 39          | <i>Paenibacillus lautus</i> strain JCM 9073                                 | 100                  | H              |

|    |    |   |     |   |
|----|----|---|-----|---|
| 21 | 40 | <i>Paenibacillus barcinonensis</i> strain BP-23 | 100 | F |
| 22 | 41 | <i>Microbacterium aerolatum</i> strain V-73     | 99  | F |
| 23 | 42 | <i>Microbacterium aerolatum</i> strain V-73     | 99  | F |

<sup>a</sup> Isolates from the rhizosphere of *Hoya carnosa*

<sup>b</sup> Isolates from the rhizosphere of *Fittonia verschaffeltii* var. *argyroneura*

Table 3.3. Counts of isolates from the rhizospheres of *Hoya carnososa* and *Fittonia verschaffeltii* var. *argyroneura* and the corresponding bacterial strains with which they had the highest percent sequence similarity.

| No. of isolates from <i>Hoya carnososa</i> | No. of isolates from <i>Fittonia argyroneura</i> | Bacterial strain with which the isolate had the maximum sequence similarity |
|--|--|---|
| 2  | 0  | <i>Paenibacillus lautus</i> strain JCM9073                                  |
| 1  | 1  | <i>Paenibacillus tundrae</i> strain Ab10b                                   |
| 1  | 11   | <i>Microbacterium aerolatum</i> strain V-73                                 |
| 0  | 1  | <i>Rhodococcus marinonascens</i> strain DSM43752                            |
| 0  | 2  | <i>Paenibacillus barcinonensis</i> strain BP-23                             |
| 0  | 2  | <i>Paenibacillus taichungensis</i> strain BCRC17757                         |
| 0  | 1  | <i>Microbacterium kribbense</i> strain MSL04                                |
| 1  | 0  | <i>Paenibacillus favisporus</i> strain GMP01                                |
| <b>5</b>                                   | <b>18</b>  | <b>Total</b>  |

Table 3.4. Percent sequence similarity matrix of the different isolates. Isolates 4, 5, 14, 16, 17, 18, and 42 were identical to isolate 32 and are not shown. Isolate 2 is identical to isolate 30, isolate 20 is identical to isolate 23, and Isolate 33 is identical to 40. Only one of the identical isolates is shown in the table below.

| Isolates | No.1 | No.10 | No.15 | No.19 | No.23 | No.24 | No.25 | No.30 | No.32 | No.33 | No.37 | No.39 | No.41 |
|----------|------|-------|-------|-------|-------|-------|-------|-------|-------|-------|-------|-------|-------|
| No.1     | 100  |       |       |       |       |       |       |       |       |       |       |       |       |
| No.10    | 81   | 100   |       |       |       |       |       |       |       |       |       |       |       |
| No.15    | 85   | 90    | 100   |       |       |       |       |       |       |       |       |       |       |
| No.19    | 85   | 90    | 99    | 100   |       |       |       |       |       |       |       |       |       |
| No.23    | 95   | 83    | 86    | 86    | 100   |       |       |       |       |       |       |       |       |
| No.24    | 86   | 90    | 96    | 95    | 87    | 100   |       |       |       |       |       |       |       |
| No.25    | 86   | 88    | 97    | 97    | 87    | 96    | 100   |       |       |       |       |       |       |
| No.30    | 93   | 84    | 87    | 87    | 95    | 88    | 87    | 100   |       |       |       |       |       |
| No.32    | 86   | 91    | 99    | 99    | 86    | 96    | 97    | 87    | 100   |       |       |       |       |
| No.33    | 94   | 84    | 87    | 87    | 99    | 88    | 88    | 95    | 87    | 100   |       |       |       |
| No.37    | 96   | 82    | 84    | 84    | 95    | 85    | 85    | 94    | 85    | 94    | 100   |       |       |
| No.39    | 99   | 82    | 86    | 86    | 95    | 87    | 87    | 93    | 86    | 94    | 96    | 100   |       |
| No.41    | 86   | 90    | 98    | 98    | 86    | 95    | 97    | 87    | 99    | 87    | 85    | 86    | 100   |

Figure 3.1. BOX-Polymerase Chain Reaction (PCR) banding patterns of isolates obtained from rhizospheres of *Hoya carnosa* and *Fittonia verschaaffeltii* var. *argyroneura*.

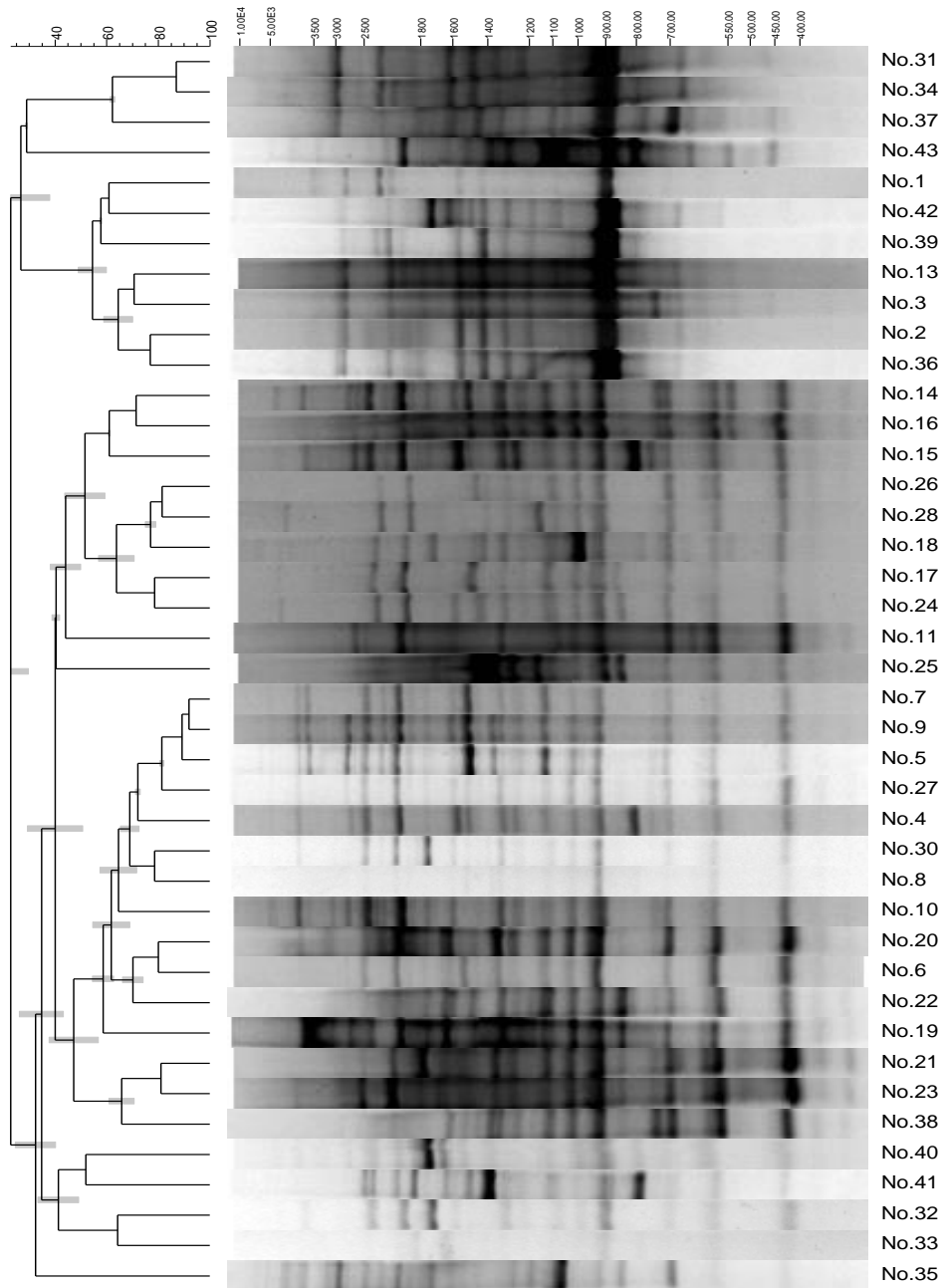

Figure 3.2. A photograph of an agarose gel of polymerase chain reaction (PCR) products for detecting toluene monooxygenase gene in the representative bacterial isolates obtained from rhizospheres of *Hoya carnosa* and *Fittonia verschaffeltii* var. *argyroneura*. All isolates were positive for the gene as indicated by the arrow that points to the right amplicon size (466 bp).

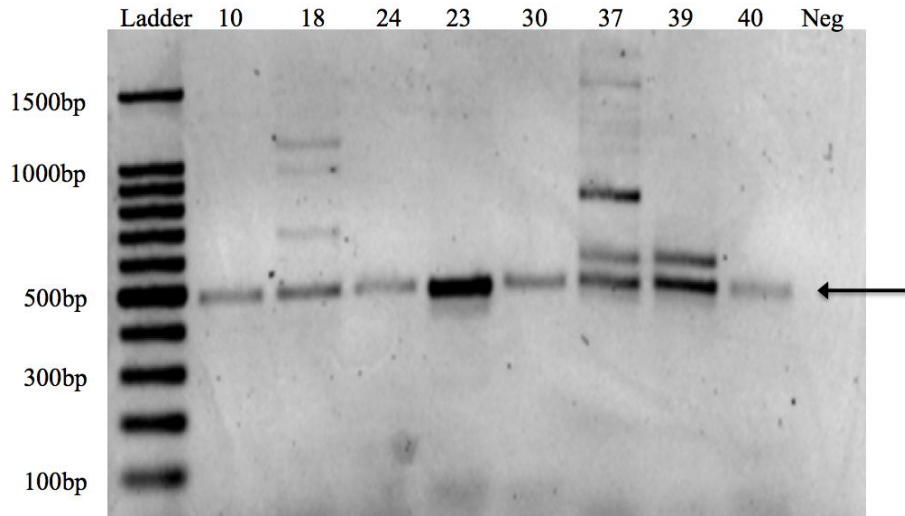
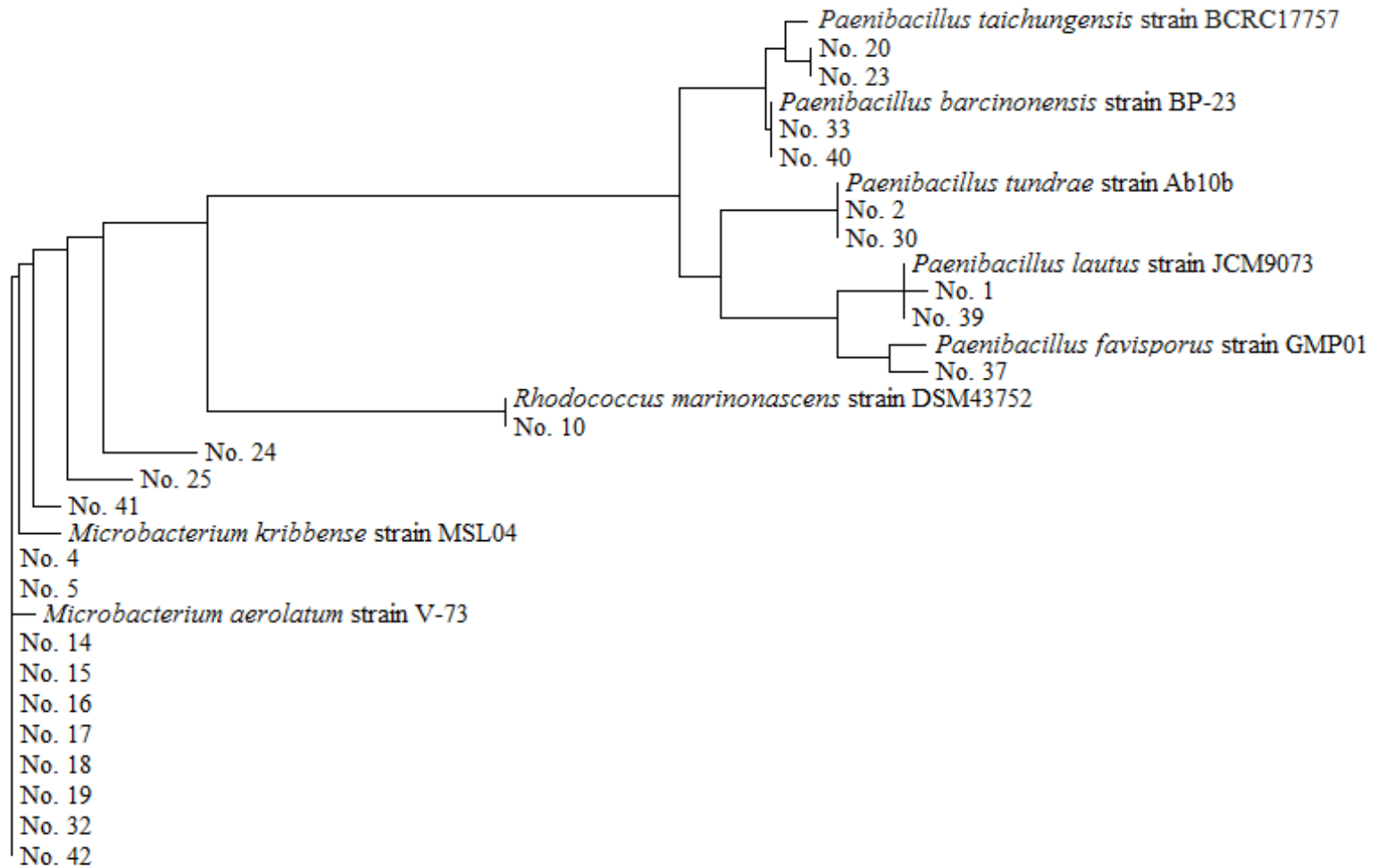

Figure 3.3. Phylogenetic tree of bacterial isolates obtained from rhizospheres of *Hoya carnosa* and *Fittonia verschaffeltii* var. *argyroneura* based on their partial 16S rDNA sequence.



CHAPTER 4  
GROWTH KINETICS STUDY OF TOLUENE METABOLIZING BACTERIA  
ISOLATED FROM RHIZOSPHERES OF TWO INDOOR PLANTS<sup>2</sup>

---

<sup>2</sup> Zhang, H., Pennisi, S.V., Kays, S.J. and M.Y. Habteselassie. To be submitted to *Soil, Water, & Air Pollution*.

## ABSTRACT

In Chapter 3, the isolation and identification of toluene metabolizing rhizosphere bacteria from two indoor plants was described. Based on their partial 16S rDNA sequences, the isolates were found to be most similar to eight known bacterial strains, which were not previously associated with toluene metabolism. In this Chapter, the isolates were investigated further to determine their growth kinetics with  $^{14}\text{C}$ -labeled toluene as the sole carbon source. The growth kinetics of the five representative isolates was investigated at four different toluene concentrations, 0.05, 0.1, 0.15, 0.2  $\mu\text{Ci}$  per ml. The percent-mineralized toluene was estimated based on the amount of  $^{14}\text{CO}_2$  released over a two week incubation time. The data for the released  $^{14}\text{CO}_2$  over time was fitted with the first order kinetic equation to obtain an estimate of the toluene degradation rate constant (b). Isolate type did not significantly affect the percent toluene mineralized, which ranged between 43.16 and 49.53 for the low and high substrate concentration, respectively. The b value was, however, significantly affected by both the isolate type and substrate concentration. Averaged over all the concentrations, the highest b value was associated with isolate 23. It appears that given enough time, all the tested isolates were similar in terms of their efficiency in metabolizing toluene. However, isolate 23 appears to be superior when it comes to the speed with which toluene was degraded. This attribute is one of the most important traits in deciding which strains to use for bioaugmentation.

## INTRODUCTION

Volatile Organic Compounds (VOCs) are known to affect indoor air quality. Some studies have indicated that VOCs are responsible for up to 70% of the variation in the total personal indoor exposure (Lee et al., 2002; Loh et al., 2007). Indoor air quality is crucial to the wellbeing of people who spend a large amount of their time indoor (Jenkins et al., 1992; Klepeis et al., 2001). Exposure to VOCs can cause both acute (e.g. Eye, nose, and throat irritations) and chronic (e.g. damage to the liver, kidneys and central nervous system, asthma and respiratory inflammation) illnesses (Ramirez et al., 2012; Rumchev et al., 2007).

It has been shown that plants are able to remove or decrease VOCs concentration, and thus can potentially be used as an inexpensive alternative to the use of activated carbon fibers (ACF) or granular activated carbon (GAC) filters to improve indoor air quality (Bastani et al., 2010; Haghghat et al., 2008). The phytoremediation potential of indoor plants was reported first by Durmishidze (1975) and Ugrekheldze (1976). In their studies with  $^{14}\text{C}$ -labeled aromatic hydrocarbons, they found out that the aromatic ring of benzene and toluene were cleaved during their metabolic transformation in plants. A number of subsequent studies have demonstrated the ability of different indoor plants to remove VOCs (Schmitz et al., 2000; Ugrekheldze et al., 1997; Yang et al., 2009; Yoo et al., 2006). What has been less investigated is the role of microorganisms that reside in the rhizosphere of indoor plants. Wolverton and Wolverton (1993) suggested that microorganisms within the rhizosphere might play an important role in VOCs removal. The study by Orwell et al. (2004) supported this statement. However, there is not much

information on rhizosphere bacteria from indoor plants when it comes to their ability to metabolize toluene, including species types and their VOCs degrading efficiency.

As described in Chapter 3 (page 47), we isolated and identified eight strains of rhizosphere bacteria with the capability to metabolize toluene from two indoor ornament plants (*Hoya carnosa* and *Fittonia verschaffeltii* var. *argyroneura*). The indoor plants were primed with toluene exposure for two months to encourage the proliferation of the rhizosphere bacteria before isolation. The bacterial isolates were genetically characterized by targeting part of their 16S rDNA. All the strains were also found to have one of the genes that are involved in toluene metabolisms (toluene monooxygenase). In this Chapter I report the results of the subsequent study that was done to characterize the growth characteristics of these bacterial isolates in metabolizing toluene by using <sup>14</sup>C-labeled toluene as substrate. Toluene labeled with <sup>14</sup>C isotope was used to conclusively and directly show that the carbon that was released in the form of CO<sub>2</sub> after microbial metabolisms came from the added toluene. Characterizing these bacterial isolates for their growth properties in relation to their toluene use is essential to identifying the isolates that are most amenable for inoculation for phytoremediation purposes.

## MATERIAL AND METHODS

### *Bacterial isolates tested*

Five of the eight unique isolates that were obtained before (see Chapter 3) were selected for further characterization of their growth properties using <sup>14</sup>C-labeled toluene. The isolates ID and the known bacterial strains to which they are most similar to are

shown in Table 4.1. The five isolates were chosen because they represented the majority of the isolates that were obtained from the two indoor plants.

#### *Culture preparation*

The five chosen isolates were obtained from -70°C freezer where they are kept for a long-term storage and thawed at room temperature. The thawed cultures (100 µl) were inoculated into conical flasks that contained 100ml of sterilized mineral salt medium (MSM) separately as described in Chapter 3. One hundred microliter (0.93 mmol) of unlabeled toluene (Baker Analyzed Reagent, J.T.Baker®, MG Scientific, Pleasant Prairie, WI) were added into each flask to provide the isolates with the sole carbon source for growth. The stoppers for the conical flasks were wrapped with polytetrafluoroethylene PTFE to prevent toluene corrosion. The flasks were incubated at 30°C in a shaker-incubator at a speed of 150 rpm until the bacteria grew into the log phase. Fifty ml of cell culture of each isolate were transferred into 50ml centrifuge tube and washed twice with phosphate buffered saline (PBS) solution to remove any residue unlabeled toluene. The cultures were eventually re-suspended with 30ml of PBS in the centrifuge tubes before incubation with the <sup>14</sup>C-labeled toluene. The growth of the bacteria was monitored with a spectrophotometer (Spectronic 20D+; Thermo Electron Corporation, Marietta, OH) at the wavelength of 600 nm. All of the cultures were diluted to the same concentration (OD<sub>600</sub>, 0.58; 10<sup>7</sup>/ml) before inoculation.

#### *Mineralization study with <sup>14</sup>C-labeled toluene*

Hundred microliter of the bacterial culture (10<sup>6</sup>) that was prepared as described above was inoculated into 125 ml septa-glass jar (Thermo Fisher Scientific, Rockwood, TN) that contained 10 ml of sterile MSM (Figure 4.1). The lead for the jar is PTFE lined

to prevent corrosion due to toluene. Ten milliliter beaker containing 0.5 ml 2N NaOH was suspended inside the jar with Teflon tap to trap the  $^{14}\text{CO}_2$  that was expected to be released from  $^{14}\text{C}$ -labeled toluene. The toluene used for the mineralization study was ring labeled with  $^{14}\text{C}$  (55mCi/mmol, purity 99%+; American Radiolabeled Chemicals, Saint Louis, MO). The mineralization study was carried out at four different toluene activities, which were 0.5, 1, 1.5, and 2  $\mu\text{Ci}$  with the corresponding specific concentrations of 0.05, 0.1, 0.15, and 0.2  $\mu\text{Ci/ml}$ . To prevent any potential loss of the  $^{14}\text{C}$ -labeled toluene through volatilization during addition to the medium, it was directly injected into a capped jar with a 5  $\mu\text{l}$  Hamilton syringe (Hamilton Company, Reno, NV). The needles were sterilized in an autoclave and were changed between isolates to avoid cross contamination during substrate addition. The toluene was also added to the jars where no isolates were inoculated at the four concentrations used in the study. These jars served as negative controls. The positive controls were jars in which the isolates were inoculated but no toluene was added. All the septa-jars were incubated under  $30^\circ\text{C}$ . All the experiments were done in triplicates.

#### *Sampling and testing*

The NaOH trap in each septa-jar was changed in a fume hood on days 1, 3, 7, 10, and 14. The NaOH solution in the beaker was transferred into a 20mL scintillation vial for counting. Five milliliter of scintillation cocktail (Fisher Scientific, Pittsburgh, PA) was added into the scintillation vial (v/v 10:1). Samples were shaken until the solution turned from turbid to clear. Counting was performed with a LS 6000 Beckman scintillation counter (Beckman Coulter, Inc., Fullerton, CA). Processing time was 5 mins on average for each sample.

### *Data analysis*

The first order equation shown below was used to fit the cumulative radioactivity of released  $^{14}\text{CO}_2$  data over time in SigmaPlot (Systat Software, Inc., San Jose, CA) to obtain an estimate of the toluene decomposition rate constant.

$$f = a*(1-e^{-b*x})$$

Where  $a$  represents the maximum toluene that can be mineralized;  $b$  represents the toluene degradation rate constant, which indicates the speed with which the toluene was metabolized by the isolates. The percent-mineralized toluene was estimated based on the activity of released  $^{14}\text{CO}_2$  and the activity of added  $^{14}\text{C}$ -labeled toluene.

The data were subjected to a two-way ANOVA in SAS 9.3 (SAS Institute, Inc., Cary, NC) to test for the statistical significance of the effects of isolate type and substrate concentration on toluene mineralization over time and decomposition rate constant ( $b$ ) at significance level of  $\alpha = 0.05$ . Least square means were used for means comparison. The data was checked for normality and homogeneity of variance before ANOVA analysis.

## RESULTS

Toluene mineralization as indicated by the cumulative amount of  $^{14}\text{CO}_2$  released over the two weeks period was not significantly affected by isolate ID ( $P = 0.7777$ ) but was significantly affected by substrate concentration ( $P < 0.0001$ ). As shown in Figure 4.2, the higher the substrate concentration the more the amount  $^{14}\text{CO}_2$  released. The pattern of the mineralization was that  $^{14}\text{CO}_2$  released rapidly in the early days of incubation, but the amount released slowed down after day 3 and gradually plateaued

thereafter. This pattern was true for all the isolates and substrate concentration tested (Figure 4.2).

The percent toluene that mineralized over the two week-time ranged between 43.16 and 49.53 for the low and high substrate concentration, respectively (Figure 4.3). The mentioned percent values are the averages for the five tested isolates, which did not have statistically significant effect. This is a difference of 15% between the lowest and highest concentrations. Except between 0.1 and 0.15  $\mu\text{Ci/ml}$ , there were statistically significant differences in % mineralized toluene between the other concentrations (Table 4.2).

The toluene degradation rate constant ( $b$ ) was significantly affected by both the isolate type ( $P = 0.0061$ ) and substrate concentration ( $P = 0.0335$ ). All the isolates had significantly different  $b$  values except for isolates 18 & 24, 24 & 30, and isolates 23, 30 & 40 (Table 4.3). Averaged over all the concentrations, the highest  $b$  value was associated with isolate 23 (-1.61/d) while isolate 18 has the lowest  $b$  value (-1.37/d) (Figure 4.4). Bigger negative  $b$  value is indicative of faster decomposition rate for toluene. Significant difference in  $b$  values was found only between 0.1 and 0.05 and between 0.05 and 0.15  $\mu\text{Ci/ml}$ . The rest of the concentrations did not result in significantly different  $b$  values (Table 4.4). The highest  $b$  value was associated with the concentration 0.15  $\mu\text{Ci/ml}$  (1.59/d) and the lowest  $b$  value was associated with the concentration 0.05  $\mu\text{Ci/ml}$  (1.39/d).

Both the negative and positive controls did not result in significant radioactivity readings (i.e., toluene mineralization) as compared to the treatments. Therefore, their values were subtracted from the treatments readings

## DISCUSSION

In Chapter 4, we reported the isolation and characterization of rhizosphere bacteria that were capable of metabolizing toluene. These bacteria were isolated from the rhizospheres of two indoor plants that were known to be superior in removing toluene from the air. Apart from isolating and genetically identifying the isolates, the bacteria were not characterized for their growth properties in the previous Chapter. In this Chapter, we are reporting the results of a study in which we used toluene, which is labeled with the rare form of carbon isotope ( $^{14}\text{C}$ ) in order to compare their growth efficiency. The use of  $^{14}\text{C}$ -labeled toluene is one of way of directly confirming the ability of the isolates to grow on the supplied toluene. When the bacteria metabolize the  $^{14}\text{C}$ -labeled toluene, they release  $^{14}\text{C}$ -labeled  $\text{CO}_2$  that is trapped in an alkaline solution for quantification, which is indicative of degree of toluene mineralization.

For this study we chose five isolates that represented the majority of the isolates that were identified in Chapter 3. These were isolates 18, 23, 24, 30 and 40. These bacterial isolates were tested for their growth characteristics at four levels of  $^{14}\text{C}$ -labeled toluene over a two weeks incubation time. The isolates did not show significant difference in their ability to metabolize toluene as indicated by the % mineralized toluene (Figure 4.3). After two weeks of incubation, the isolates, on average, mineralized 43.16, 44.42, 45.68, and 49.53 of the toluene that was introduced at 0.05, 0.1, 0.15 and 0.2 $\mu\text{Ci/ml}$  concentrations, respectively. All of the five isolates mineralized more at higher levels of toluene concentration. The percentage of mineralized toluene was as a result the highest when the substrate concentration was 0.2 $\mu\text{Ci/ml}$ . The incubation study was

terminated after two weeks as the cumulative amount of released  $^{14}\text{CO}_2$  from the toluene leveled off, indicating the slowing down of the process.

The pattern of toluene decomposition was well modeled by the first order kinetics equation ( $R^2 = 0.9937 \pm 0.0022$ ). One of the parameters of this model is  $b$ , which is negative and indicative of how fast the toluene is mineralized by the individual isolate. Even though the overall percent toluene mineralized was not significantly different between the isolates, there was significant difference in  $b$  values between them. Based on the  $b$  value, isolate 23 was the responsible for the fastest toluene mineralization rate when averaged over all the concentrations. Isolate 18 on the other hand was responsible for the slowest rate of toluene mineralization. This suggests the isolates resulted in similar amount of mineralized toluene at different rates.

The main goal of this study was to identify bacterial isolates that are superior in metabolizing toluene for the purpose of bioaugmentation with indoor plants to enhance their phytoremediation potential. It appears that given significant time, all the tested isolates were similar in terms of their efficiency in metabolizing toluene. However, isolate 23 appears to be superior when it comes to the speed with which toluene was degraded. This is an important trait in deciding which strain to use for bioaugmentation, especially in instances where quick result is needed when toluene concentration is high.

Compared to the traditional way of isolating strains for bio-augmentation purposes, the bacteria that we isolated through priming and rhizo-directed selection have some advantages. Strains selected from the rhizosphere are capable of growing on root exudates in addition to degrading the relevant pollutant. The bacteria, once inoculated into the appropriate plant rhizosphere, would express the pollutant-degrading enzymes,

thereby decontaminating the soil while still benefitting from the plant root exudates to sustain its population and metabolic activity (Singer et al., 2003; Singer et al., 2004). The inoculum, in return, can provide protection to the plant against phytotoxic chemicals. The probable synergistic relationship between the plant and the inoculum may be more resilient, sustainable and cost-effective than the standard bioaugmentation approach. The best bioaugmentation practice might, however, be the introduction of a mixture isolates thereby creating a bacterial consortium which is potentially more resilient to stress than a single isolate (Singer et al., 2005).

## REFERENCES

- Bastani, A., Lee, C.-S., Haghghat, F., Flaherty, C., and Lakdawala, N. (2010). Assessing the performance of air cleaning devices – A full-scale test method. *Building and Environment* 45, 143-149.
- Durmishidze, S. V. (1975). "Cleavage of the aromatic ring of some exogenous compounds in plants," Metsniereba, Tbilisi, Russian.
- Haghghat, F., Lee, C.-S., Pant, B., Bolourani, G., Lakdawala, N., and Bastani, A. (2008). Evalutaion of various activated carbons for air cleaning - Towards design of immune and sustainalbe buildings. *Atmos. Environ.* 42, 8176-8184.
- Jenkins, P. L., Phillips, T. J., Mulberg, E. J., and Hui, S. P. (1992). Activity patterns of Californians: Use of and proximity to indoor pollutant sources. *Atmospheric Environment. Part A. General Topics* 26, 2141-2148.
- Klepeis, N. E., Nelson, W. C., Ott, W. R., Robinson, J. P., Tsang, A. M., Switzer, P., Behar, J. V., Hern, S. C., and Engelmann, W. H. (2001). The National Human Activity Pattern Survey (NHAPS): a resource for assessing exposure to environmental pollutants. *J Expo Anal Environ Epidemiol* 11, 231-52.
- Lee, S.-C., Guo, H., Li, W.-M., and Chan, L.-Y. (2002). Inter-comparison of air pollutant concentrations in different indoor environments in Hong Kong. *Atmospheric Environment* 36, 1929-1940.
- Loh, M. M., Levy, J. I., Spengler, J. D., Houseman, E. A., and Bennett, D. H. (2007). Ranking cancer risks of organic hazardous air pollutants in the United States. *Environ Health Perspect* 115, 1160-8.

- Orwell, R., Wood, R., Tarran, J., Torpy, F., and Burchett, M. (2004). Removal of Benzene by the Indoor Plant/Substrate Microcosm and Implications for Air Quality. *Water, Air, and Soil Pollution* 157, 193-207.
- Ramirez, N., Cuadras, A., Rovira, E., Borrull, F., and Marce, R. M. (2012). Chronic risk assessment of exposure to volatile organic compounds in the atmosphere near the largest Mediterranean industrial site. *Environ Int* 39, 200-9.
- Rumchev, K., Brown, H., and Spickett, J. (2007). Volatile organic compounds: do they present a risk to our health? *Rev Environ Health* 22, 39-55.
- Schmitz, H., Hilgers, U. T. E., and Weidner, M. (2000). Assimilation and metabolism of formaldehyde by leaves appear unlikely to be of value for indoor air purification. *New Phytologist* 147, 307-315.
- Singer, A. C., Crowley, D. E., and Thompson, I. P. (2003). Secondary plant metabolites in phytoremediation and biotransformation. *Trends Biotechnol* 21, 123-30.
- Singer, A. C., Thompson, I. P., and Bailey, M. J. (2004). The tritrophic trinity: a source of pollutant-degrading enzymes and its implications for phytoremediation. *Curr Opin Microbiol* 7, 239-44.
- Singer, A. C., van der Gast, C. J., and Thompson, I. P. (2005). Perspectives and vision for strain selection in bioaugmentation. *Trends Biotechnol* 23, 74-77.
- Ugrekheldze, D. (1976). "Metabolism of Exogenous Alkanes and Aromatic Hydrocarbons in Plants," Metsniereba, Tbilisi, Russian.
- Ugrekheldze, D., Korte, F., and Kvesitadze, G. (1997). Uptake and transformation of benzene and toluene by plant leaves. *Ecotoxicol Environ Saf* 37, 24-9.

- Wolverton, B. C., and Wolverton, J. D. (1993). Plants and soil microorganisms: removal of formaldehyde, xylene, and ammonia from the indoor environment. *Journal of the Mississippi Academy of Sciences* 38, 11-15.
- Yang, D. S., Pennisi, S. V., Son, K., and Kays, S. J. (2009). Screening indoor plants for volatile organic pollutant removal efficiency. *HortScience* 44, 1377-1381.
- Yoo, M. H., Kays, S. J., Son, K. C., and Kwon, Y. J. (2006). Efficacy of indoor plants for the removal of single and mixed volatile organic pollutants and physiological effects of the volatiles on the plants. *Journal of the American Society for Horticultural Science* 131, 452-458.

Table 4.1. Bacterial isolates that were tested for toluene use efficiency. The isolates were obtained from the rhizospheres of two indoor plants, *Hoya carnosa* and *Fittonia verschaffeltii* var. *argyroneura*

| Isolates ID | Best Matches  | Sources                           |
|-------------|---|-----------------------------------|
| No. 18      | <i>Microbacterium aerolatum</i> strain V-73         | H <sup>a</sup> and F <sup>b</sup> |
| No. 23      | <i>Paenibacillus taichungensis</i> strain BCRC17757 | F                                 |
| No. 24      | <i>Microbacterium kribbense</i> strain MSL04        | F                                 |
| No. 30      | <i>Paenibacillus tundrae</i> strain Ab10b           | H and F                           |
| No. 40      | <i>Paenibacillus barcinonensis</i> strain BP-23     | F                                 |

<sup>a</sup> Isolates from the rhizosphere of *Hoya carnosa*

<sup>b</sup> Isolates from the rhizosphere of *Fittonia verschaffeltii* var. *argyroneura*

Table 4.2. Least square means comparisons between substrate concentrations for their effect on percent toluene mineralized over the two weeks incubation time.

| Concentrations ( $\mu\text{Ci/ml}$ )<br>for comparison |      | Difference in least<br>square means | Standard<br>error | P value* |
|--|------|-------------------------------------|-------------------|----------|
| 0.1  | 0.2  | -4.9423                             | 0.7030            | <.0001   |
| 0.1  | 0.05 | 1.6325                              | 0.7030            | 0.0209   |
| 0.1  | 0.15 | -1.2669                             | 0.7030            | 0.0726   |
| 0.2  | 0.05 | 6.5748                              | 0.7030            | <.0001   |
| 0.2  | 0.15 | 3.6755                              | 0.7030            | <.0001   |
| 0.05   | 0.15 | -2.8994                             | 0.7030            | <.0001   |

\*P value less than or equal to 0.05 indicates significant differences between two concentrations being compared.

Table 4.3. Least square means comparisons between isolates for their effect on the decomposition rate constant (b).

| Isolates for comparison |    | Difference in least square means | Standard error | P value* |
|-------------------------|----|----------------------------------|----------------|----------|
| 18                      | 23 | -0.2403                          | 0.0782         | 0.0034   |
| 18                      | 24 | -0.0534                          | 0.0782         | 0.4970   |
| 18                      | 30 | -0.1984                          | 0.0782         | 0.0143   |
| 18                      | 40 | -0.2373                          | 0.0782         | 0.0038   |
| 23                      | 24 | 0.1868                           | 0.0782         | 0.0207   |
| 23                      | 30 | 0.0418                           | 0.0782         | 0.5945   |
| 23                      | 40 | 0.0029                           | 0.0782         | 0.9702   |
| 24                      | 30 | -0.1449                          | 0.0782         | 0.0696   |
| 24                      | 40 | -0.1839                          | 0.0782         | 0.0226   |
| 30                      | 40 | -0.0389                          | 0.0782         | 0.6205   |

\*P value less than or equal to 0.05 indicates significant differences between two concentrations being compared.

Table 4.4. Least square means comparisons between substrate concentrations for their effect on the decomposition rate constant (b).

| Concentrations ( $\mu\text{Ci/ml}$ )<br>for comparison |      | Difference in least<br>square means | Standard<br>error | P value* |
|--|------|-------------------------------------|-------------------|----------|
| 0.1  | 0.2  | -0.0217                             | 0.0699            | 0.7579   |
| 0.1  | 0.05 | 0.1345                              | 0.0699            | 0.0599   |
| 0.1  | 0.15 | -0.0699                             | 0.0699            | 0.3226   |
| 0.2  | 0.05 | 0.1562                              | 0.0699            | 0.0299   |
| 0.2  | 0.15 | -0.0482                             | 0.0699            | 0.4940   |
| 0.05   | 0.15 | -0.2044                             | 0.0699            | 0.0052   |

\*P value less than or equal to 0.05 indicates significant differences between two concentrations being compared.

Figure 4.1. The microcosm set-up for the mineralization study with  $^{14}\text{C}$  labeled toluene.

A. Hamilton syringe, B. The alkaline trap (2N NaOH), C. Mineral salt medium where the isolates and the radio-labeled toluene were injected into

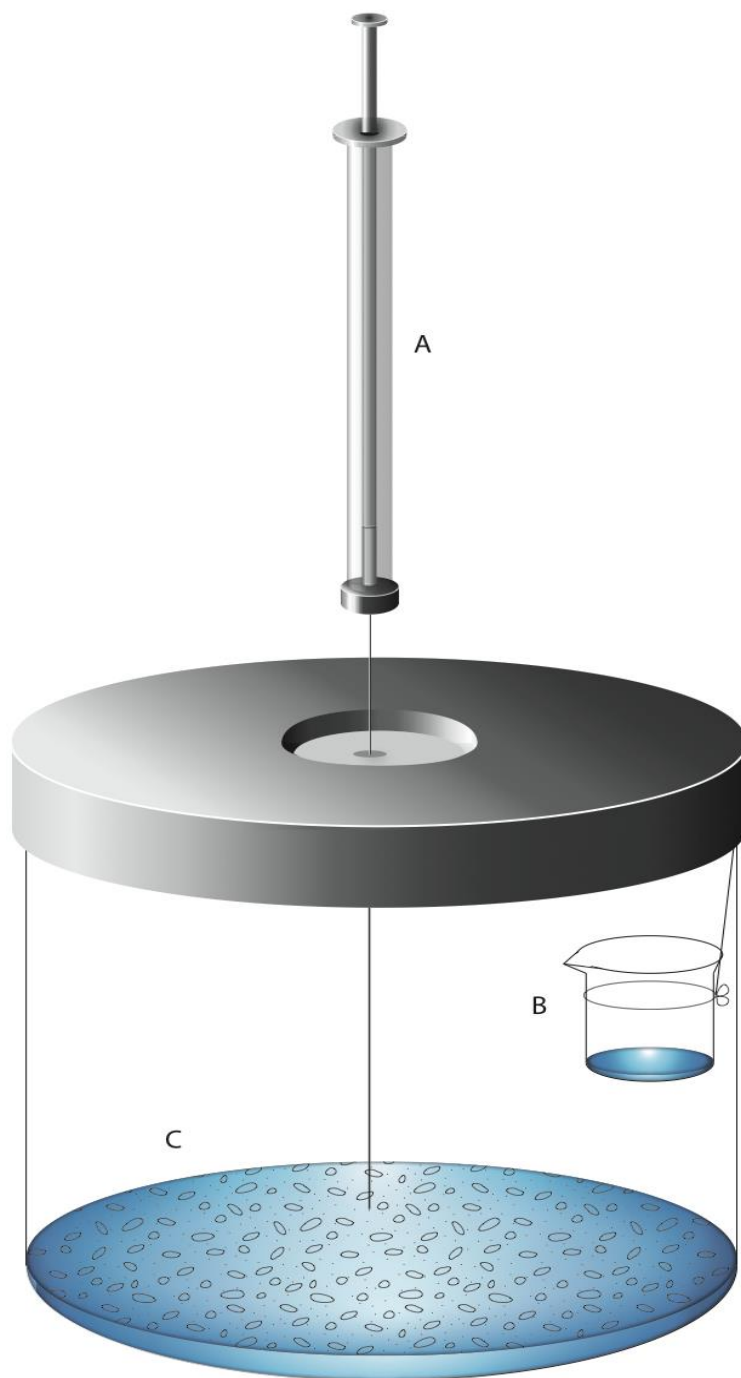

Figure 4.2. Cumulative amount of released  $^{14}\text{CO}_2$  (disintegration per minute, DPM) from the mineralized toluene over two weeks time.

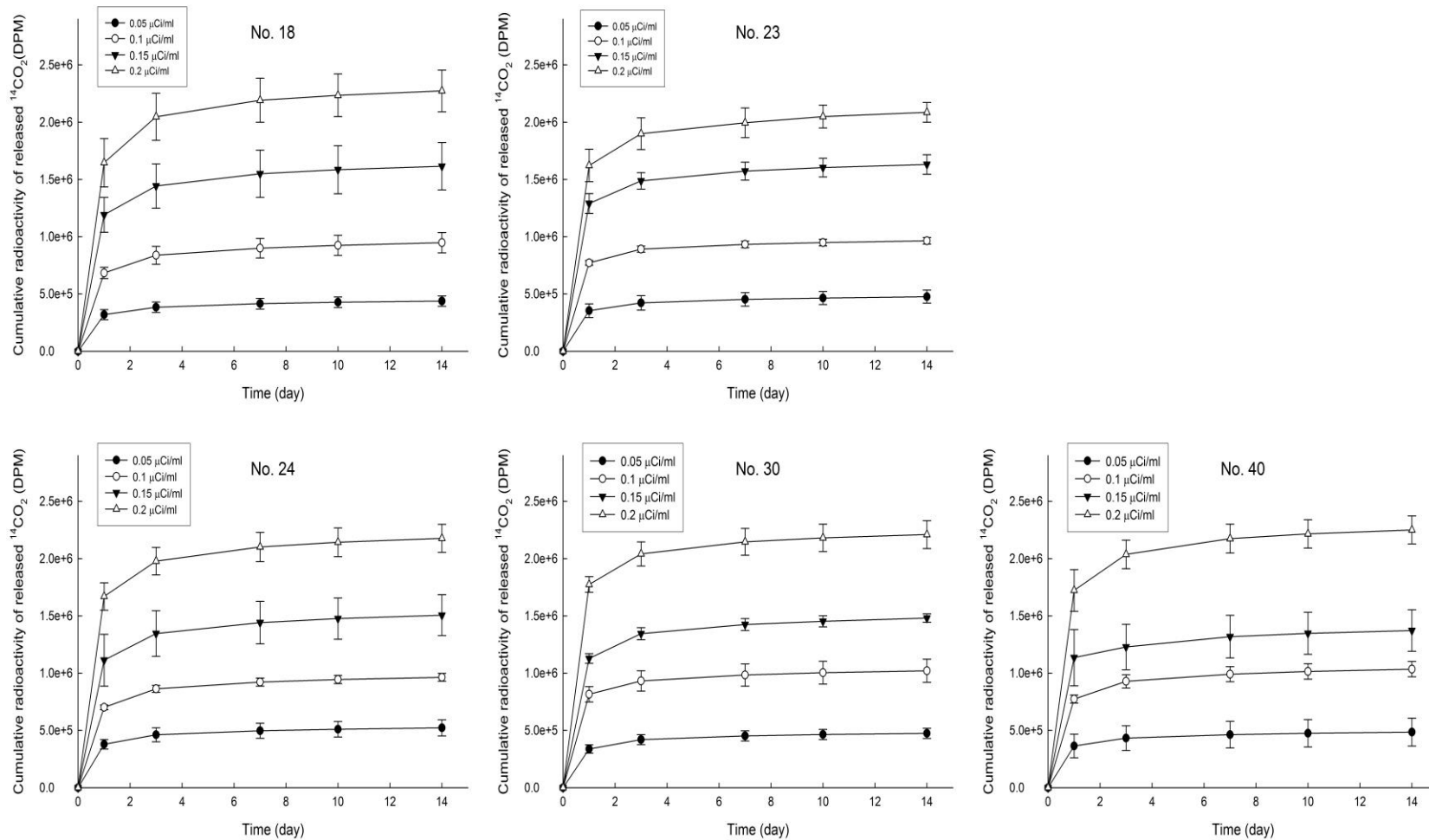

Figure 4.3. Percentage of mineralized toluene after 14 days of incubation

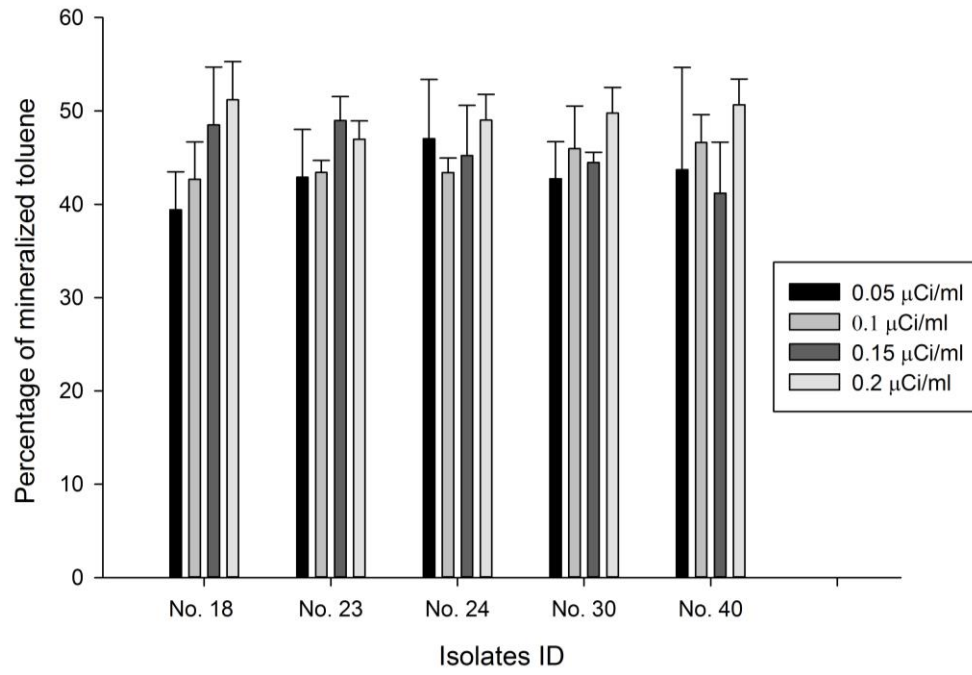
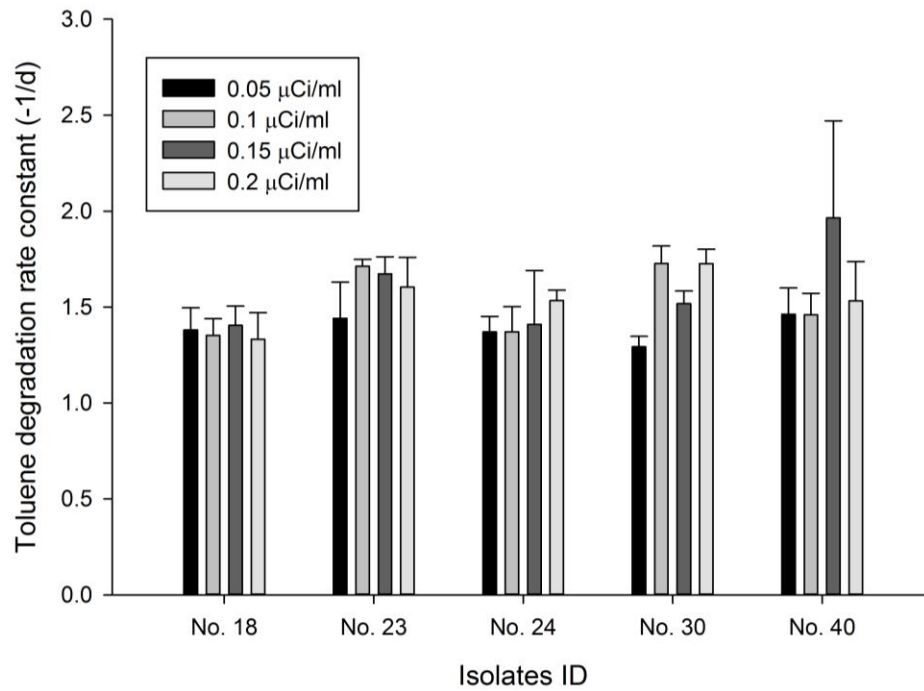

Figure 4.4. Toluene degradation rate constant (b) of isolates under four different concentrations



## CHAPTER 5

### SUMMARY AND CONCLUSION

The main purpose of the study was to gain knowledge of the identity and growth properties of bacteria that are indigenous to the rhizospheres of indoor plants with superior capability to remove volatile organic compounds (VOCs) from indoor environments. Chapter 3 described the isolation and identification of rhizosphere bacteria that are capable of metabolizing toluene, a VOC that is ubiquitous in indoor environments, as a sole carbon source. Forty-two bacterial isolates were obtained from the rhizospheres of two indoor plants, *F. verschaffeltii* and *H. carnososa*. The number was narrowed to twenty three using a molecular fingerprinting technique called BOX-PCR. Further molecular characterization of the isolates showed that they had the highest sequence similarities to eight known bacteria strains, which were not previously known to metabolize toluene. The toluene monooxygenase gene was detected in all the bacterial isolates, confirming their potential to metabolize toluene. In general, isolates obtained from *F. verschaffeltii* were more diverse and abundant than isolates obtained from *H. carnososa*.

The subsequent study that is described in Chapter 4 examined the growth kinetics of the isolated bacteria. Five representative isolates were selected for further study with  $^{14}\text{C}$ -labeled toluene as sole carbon source at four different toluene concentrations (0.05, 0.1, 0.15, 0.2  $\mu\text{Ci}$  per ml). The percent-mineralized toluene was estimated based on the amount of  $^{14}\text{CO}_2$  released over a two weeks' incubation time. The data for the released

$^{14}\text{CO}_2$  over time was fitted with the first order kinetic equation to obtain an estimate of the toluene degradation rate constant (b). Isolate type did not significantly affect the percent toluene mineralized, which ranged between 43.16 and 49.53 for the low and high substrate concentration, respectively. The b value was, however, significantly affected by both the isolate type and substrate concentration. Averaged over all the concentrations, the highest b value was associated with isolate 23. It appears that given enough time, all the tested isolates were similar in terms of their efficiency in metabolizing toluene. However, isolate 23 appears to be superior when it comes to the speed with which toluene was degraded. This attribute is one of the most important traits in deciding which strains to use for bioaugmentation.

The isolation and characterization of toluene metabolizing bacteria in this study corroborates previous speculation that the rhizosphere microbial community contributes to the phytoremediation potential of indoor foliage plants. The ultimate goal of this research was to select bacteria that have superior VOC degrading ability and re-inoculate them back into the rhizosphere of the host plant or other indoor plants to improve their VOC degrading performance. The concept of inoculating microorganisms into contaminated sites to facilitate degradation of pollutants, also known as bioaugmentation, is widely practiced in outdoor environments. The effectiveness of bioaugmentation application in *in-situ* has been commonly hampered due to the low survival rate of the inoculated microorganisms as a result of low nutrient availability and adverse and fluctuating conditions in the outside environment. With indoor settings, however, the environmental conditions are usually strictly controlled and the plants are supplied with sufficient water and nutrients. As a result, bio-augmentation would

potentially have a higher rate of success in improving indoor air quality using living plants. This assumption would be tested in future work, whereby microbial isolates from this study will be introduced to rhizospheres of other species of indoor plants in an effort to enhance their potential in removing toluene.