

Technical Report Series
Number 85-2

FINFISHING WITH SHRIMP BOATS

A Summary of Georgia's
Cooperative Finfish Development
and Fishing Demonstration
Project for 1983

P.A. Christian
and
D.L. Harrington

Georgia Marine Science Center
University System of Georgia
Skidaway Island, Georgia

FINFISHING WITH SHRIMP BOATS

A Summary of Georgia's
Cooperative Finfish Development
and Fishing Demonstration
Project for 1983

Technical Report 85-2

by

P. A. Christian and D. L. Harrington
The University of Georgia
Marine Extension Service
P. O. Box Z
Brunswick, Georgia 31523

The Technical Report Series of the Georgia Marine Science Center is issued by the Georgia Sea Grant Program and the Marine Extension Service of the University of Georgia on Skidaway Island (P. O. Box 13687, Savannah, Georgia 31416). It was established to provide dissemination of technical information and progress reports resulting from marine studies and investigations mainly by staff and faculty of the University System of Georgia. In addition, it is intended for the presentation of techniques and methods, reduced data, and general information of interest to industry, local, regional, and state governments and the public. Information contained in these reports is in the public domain. If this publication is cited, it should be cited as an unpublished manuscript. This work was supported by the NOAA Office of Sea Grant, Department of Commerce, under grant NA80AA-D-00091.

ABSTRACT

Five shrimp boats were involved in a cooperative program to determine the feasibility of shrimp boats diversifying into offshore finfishing in the Georgia Bight. Three vessels were modified for bottom longlining. They produced 32,578 pounds of snowy grouper, grey tilefish, and golden tilefish which had an ex-vessel value of \$38,547. This represents a combined effort of 38 fishing days and 155 bottom longline sets which averaged 210 pounds of fish per set.

The two vessels that were fish trawling produced a gross stock of 26,413 pounds of fish, predominantly red snapper, scamp, gag grouper, vermillion snapper, red or pink porgy, and whitebone porgy which had an ex-vessel value of \$28,562. This represents a combined effort of 28 fishing days and 108 tows, averaging 245 pounds of fish per tow.

Much of the effort by the two boats which fish trawled was devoted to development and testing of gear and handling procedures. Three nets and sweep combinations were used: a 4-seam high opening fish trawl with a rock hopper sweep, a mongoose fish trawl with a rock hopper sweep, and a Burbank fish trawl with standard cookie rollers on the sweep.

THIS PAGE LEFT INTENTIONALLY BLANK

ACKNOWLEDGMENTS

The completion of this project would not have been possible without the cooperation and assistance of the following captains and their crews: Captain Charlie Phillips, Captain Roy Purvis, Captain Raleigh Purvis, Captain Joe Webster, and Captain Jimmy Moore.

Amanda Parker, Jack Rivers, and Jackie EuDaly also deserve recognition for their help in drawing and photographing the figures.

Finally, a special thanks goes to Lura Relihan, Kathy Bennett and Laura Pittman for typing, proofing, and helping to finalize this report.

THIS PAGE LEFT INTENTIONALLY BLANK

Table of Contents

	<u>Page</u>
Abstract	i
Acknowledgments	iii
List of Figures	vii
List of Tables	ix
List of Appendices	xi
Introduction	1
Background	1
Methods	2
Results and Discussion	4
Bottom Longlining - M/V BLACKBEARD	4
Bottom Longlining - M/V CREDIT	20
Bottom Longlining - M/V WAR HORSE	34
Fish Trawling - M/V PO BOY	38
Fish Trawling - M/V CAPT. MERRITT	51
Summary	55
Appendices	61

THIS PAGE LEFT INTENTIONALLY BLANK

List of Figures

<u>Figure</u>	<u>Page</u>
1. Snood arrangement used by Captain Phillips	7
2. Location of Captain Phillips' longline reel	8
3. Location of control lever that operates the bottom longline reel	9
4. Baiting table used to hold baited snoods before clipping them onto main cable	10
5. Generalized hauling and setting procedures	12
6. Star coupler or lovejoy connector, originally purchased	18
7. Replacement star coupler or lovejoy of heavier, stronger construction	19
8. Snood design used by Captain Roy Purvis	22
9. Location of Captain Roy Purvis' longline reel	23
10. Longline reel from the M/V CREDIT showing homemade chain-driven levelwind	24
11. Detail of swivel guide welded to the top of one chain link, M/V CREDIT	25
12. Detail of hydraulic motor drive system and 60:1 reduction transmission, M/V CREDIT	27
13. Setting out and hauling back procedures for the M/V CREDIT	28
14. Diagram comparing rock hopper sweep to a roller-rigged sweep	39
15. Diagram of bracket used on 10-foot wooden shrimp doors by Captain Joe Webster	41
16. Schematic of a 4-seam high-opening fish trawl	42

<u>Figure</u>	<u>Page</u>
17. Schematic of a mongoose fish trawl	43
18. Bracket used on standard 10' x 44" wooden shrimp door	46
19. Cookie sweep construction used on Billy Burbank 105' fish trawl	52
20. Schematic of door-to-net arrangement used by Captain Moore	54

List of Tables

<u>Table</u>	<u>Page</u>
1. Expenditures from the addition of a bottom longline reel to the M/V BLACKBEARD	5
2. Trip summary for the M/V BLACKBEARD, 1983	14
3. Trip expenses and income generated for the M/V BLACKBEARD	15
4. Catch summary before packing and freight for the M/V BLACKBEARD	16-17
5. Expenditures from the addition of a bottom longline reel to the M/V CREDIT	21
6. Trip summary for the M/V CREDIT, 1983	29
7. Trip expenses and income generated for the M/V CREDIT	30
8. Catch summary before packing and freight for the M/V CREDIT	31-33
9. Trip summary for the M/V WAR HORSE, 1983	36
10. Catch summary before packing and freight for the M/V WAR HORSE	37
11. Trip summary for the M/V PO BOY, 1983	47
12. Trip expenses and income generated for the M/V PO BOY	48
13. Catch summary before packing and freight for the M/V PO BOY	49-50
14. Trip summary for the M/V CAPT. MERRITT, 1983	56
15. Catch summary before packing and freight for the CAPT. MERRITT	57-59

THIS PAGE LEFT INTENTIONALLY BLANK

List of Appendices

<u>Appendix</u>	<u>Page</u>
A. Trip Logs for Captain Charlie Phillips, M/V BLACKBEARD, Bottom Longlining	63
B. Trip Logs for Captain Roy Purvis, M/V CREDIT, Bottom Longlining	71
C. Trip Logs for Captain Raleigh Purvis, M/V WAR HORSE, Bottom Longlining	81
D. Trip Logs for Captain Joe Webster, M/V PO BOY, Rock Hopper-Rigged Fish Trawling	84
E. Trip Logs for Captain Jimmy Moore, M/V CAPT. MERRITT, Roller-Rigged Fish Trawling	90

INTRODUCTION

In 1983, during the offseason, five shrimp boat operators participated in a cooperative effort to investigate the feasibility of using traditional shrimp boats for harvesting finfishes. The results of this project are presented in this report and include the following:

- (1) Descriptions of boat conversions and cost data
- (2) Diagrams and descriptions of gear modifications
- (3) Descriptions of fishing methods
- (4) Captains' trip logs, including catch data and loran readings of locations fished
- (5) Trip summaries, including market outlets, prices, expenses, and problems

This program was supported by the Gulf and South Atlantic Fisheries Foundation, the Georgia Sea Grant Program and the University of Georgia's Marine Extension Service.

BACKGROUND

This project is part of an ongoing program to explore the feasibility of establishing alternate fisheries for shrimp boat operators in the Southeast. The GEORGIA BULLDOG, a typical 73-foot shrimp boat operated by the University of Georgia's Marine Extension Service and Sea Grant Program, was converted to a multiple purpose fishing vessel and is actively engaged in this effort, particularly in exploratory offshore fishing and gear development.

As a logical extension of the work carried out on the GEORGIA BULLDOG, it was desirable to involve commercial shrimp boat operators who would make the necessary conversions to their boats and fish them on a commercial basis. Moreover, problems of industry are often solved by industry or by a joint effort between industry and researchers. The use of cooperating vessels allows for the testing of ideas generated by the practical experience of shrimp boat operators, and for greater coverage of offshore

fishing grounds. Fishing these boats on a commercial scale permits more realistic economic evaluations.

METHODS

Of the five boats participating in this project, three were rigged for bottom longlining and two were converted for bottom fish trawling. The characteristics of the five boats, names of the captains, and fishing methods are as follows:

- (1) Captain Charlie Phillips
Boat Name: BLACKBEARD
Home Port: Bellville, Georgia
Size: 68 ft., LOA
Hull: Fiberglass, Desco Marine
Engine: Caterpillar 3412 diesel with a 5:1 reduction gear
Fishing Method: Bottom longlining
- (2) Captain Roy Purvis
Boat Name: CREDIT
Home Port: Brunswick, Georgia
Size: 75 ft., LOA
Hull: Steel, Georgetown, South Carolina
Engines: Twin Cummings 250 diesels with 4.5:1 reduction gear
Fishing Method: Bottom longlining
- (3) Captain Raleigh Purvis
Boat Name: WAR HORSE
Home Port: Brunswick, Georgia
Size: 73 ft., LOA
Hull: Wood, St. Augustine Trawler
Engine: Caterpillar 343 diesel with a 6:1 reduction gear
Fishing Method: Bottom longlining

- (4) Captain Joe Webster
Boat Name: PO BOY
Home Port: Richmond Hill, Georgia
Size: 72 ft., LOA
Hull: Wood, Desco Marine
Engine: Caterpillar 3408 diesel with a 6:1 reduction gear
Main Winch: Stroudsburg 515-1/2 T
Fishing Method: Rock hopper-rigged fish trawling
- (5) Captain Jimmy Moore
Boat Name: CAPT. MERRITT
Home Port: South Port, North Carolina
Size: 69 ft., LOA
Hull: Fiberglass, Desco Marine
Engine: Cummings KT 1150 diesel with a 6:1 reduction gear
Main Winch: McLeroy 520
Fishing Method: Roller-rigged (cookie sweep) fish trawling

All information in this report was given freely by the cooperating captains as part of an initial agreement that the information was public property and was to be made available to other commercial fishermen.

Information was collected from each of the boat captains on a trip-by-trip basis. Copies of the captains' logs, packing slips, shipping slips, prices received for fish, and expenditures, (i.e. fuel, ice, bait, and groceries) were collected after each trip. Personal interviews were conducted to gather additional information such as problems that occurred, gear modifications, locations fished, changes in fishing techniques, or anything that might be considered important.

Conversion expenses for each boat were derived by interviewing each captain and summarizing bills. Anything done to the boat, such as general maintenance or work that could be attributed to shrimping, was not included as a conversion expense.

Any mention of a particular brand name, company, or fish market in this report is not an endorsement.

RESULTS AND DISCUSSION

The results of the 1983 cooperative finfishing project are given on an individual boat basis. Boat modifications with gear descriptions and conversion costs are presented followed by methods of setting/retrieving gear. Finally, trip summaries are presented which include number of fishing days, total catch, fishing effort, locations fished, catch per unit effort information, marketing information, expenses per trip, and problems encountered.

1. BOTTOM LONGLINING - M/V BLACKBEARD - Captain Charlie Phillips

A. Conversion expenses for the M/V BLACKBEARD

1. Longline reel: Captain Phillips purchased his reel from Port Canaveral Maintenance and Fabrication, Inc., Cape Canaveral, Florida. Total cost for reel, hydraulic motor, tank, valves, hoses, and labor was \$4,324.82. For a detailed list of materials, see Table 1.
2. Hydraulic drive system: Reduction gear and housing from transmission to hydraulic pump were installed at a total cost of \$535.
3. Freezer: Captain Phillips modified the front section of his ice bin as a freezer. He planned to save scrap fish from his shrimping by-catch to use for bait. A semi-truck Thermo-King unit was modified and installed and a 4-cylinder Mercedes diesel was installed to drive a 1-kilowatt generator to power the compressor. The cost of the used freezer unit was \$3,000. The keel cooler for the Mercedes diesel was installed at a cost of \$566.82. Labor to install the whole freezer package cost \$1,800. Total cost for the freezer unit was \$5,366.82.

Table 1. Expenditures from the addition of a bottom longline reel to the M/V BLACKBEARD

Materials:

1 - 36" longline reel	\$2,500.00
1 - hydraulic pump	318.00
Fitting for pump	3.00
55 gallons hydraulic oil	190.00
55 gallon hydraulic tank	165.00
1 - SP-4 control valve	92.00
1 - 1" x 10' suction hose	70.00
1 - filter	45.00
1 - relief valve	34.00
2 - 3/4" ball valve	44.00
1 - 1/2" ball valve	19.00
2 - 1-1/4" gate valve	55.00
1 - 3/4" x 24" hose	12.30
2 - 3/4" x 20' hose @ \$69.36	138.72
2 - 1/2" x 3' hose @ \$10.40	20.80
2 - 1/2" x 15' hose @ \$34.00	68.00
Miscellaneous fittings	<u>50.00</u>
Total materials	\$3,824.82
Labor - 20 hours @ \$25.00	<u>500.00</u>
Total	\$4,324.82

4. Bottom longline cable: 25,000 feet of new 3/16" galvanized electrode cable with aluminum stops every 20 feet was purchased from Dawson Pipe and Cable Co., Portland, Texas. The cost of the cable with shipping was \$2,500.
 5. Branch lines or snoods: Captain Phillips constructed his snoods similar to those used by the University of Georgia's fishery research vessel, GEORGIA BULLDOG (Figure 1). Materials for 1,200 snoods were purchased from SNL Corporation, Sebastian, Florida, at a cost of \$1,511. An additional \$200 was paid to his crew for labor to construct the snoods. Total cost for 1,200 snoods was \$1,711.
 6. Total conversion costs: \$14,437.64.
- B. Description and methods of gear deployment for the M/V BLACKBEARD
1. Location of reel: Captain Phillips mounted his longline reel above his shrimp winch, just aft of the wheelhouse. This location was ideal because the reel was easily accessible and out of the way when shrimping. The A-frame mast on the M/V BLACKBEARD allowed for easy mounting of the longline reel (Figure 2).
 2. Location and operation of hydraulic controls: The winch controls (Figure 3) consisted of a two-way valve with lever and a by-pass connection. These were located midship on the port rail just below the wire retrieval davit. Operation of the control lever was done by pressing against the lever with one leg, allowing both hands to be free.
 3. Setting and retrieving operations: Just before sunrise, the crew would bait 500 to 1,000 hooks and set them on a specially designed baiting table (Figure 4). This table held the baited snoods and prevented entanglement. While the crew did this, Captain Phillips would approach a desired fishing spot and check the drift speed and current direction. He would then steam up current and go slightly past the desired fishing spot. The terminal end of the

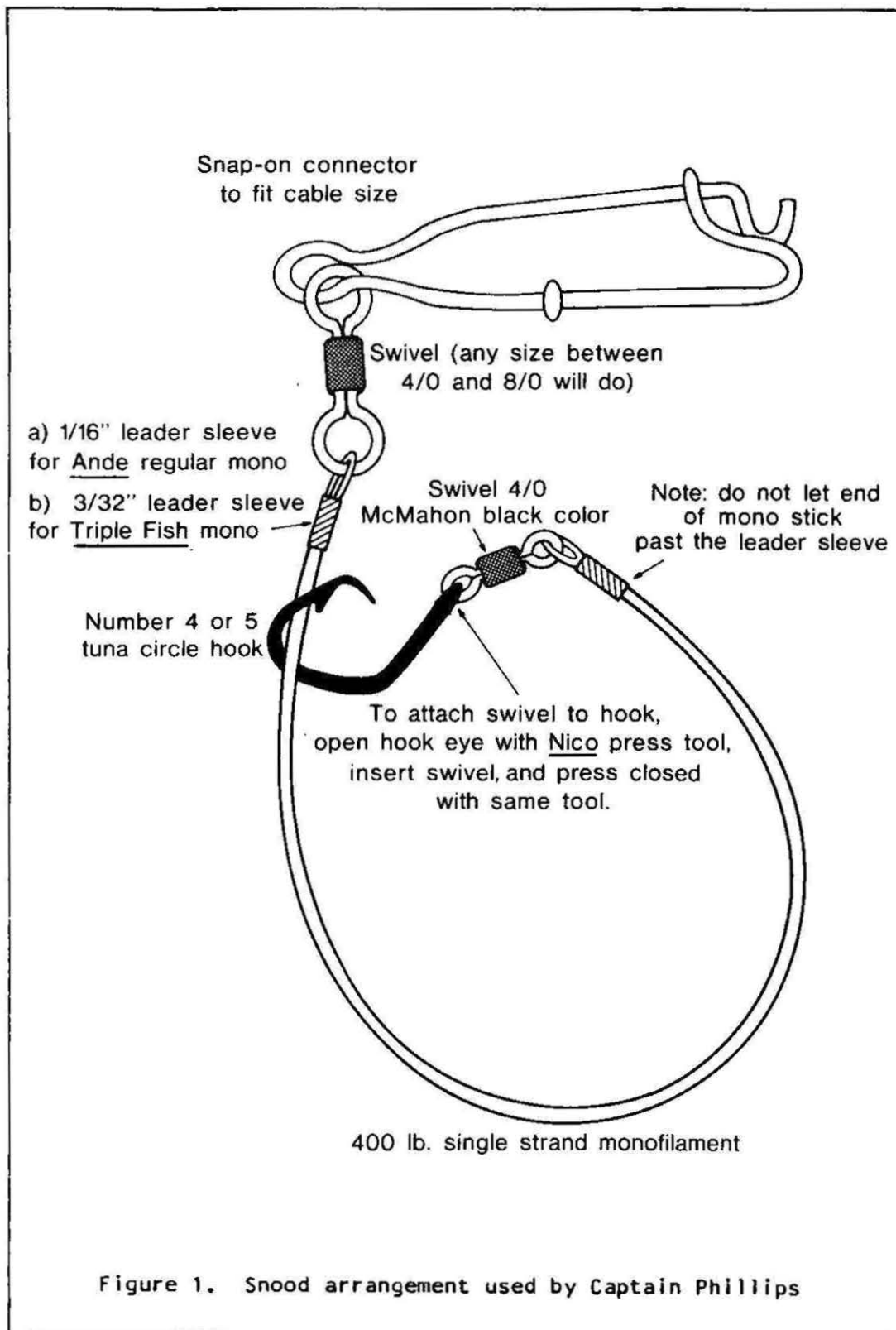

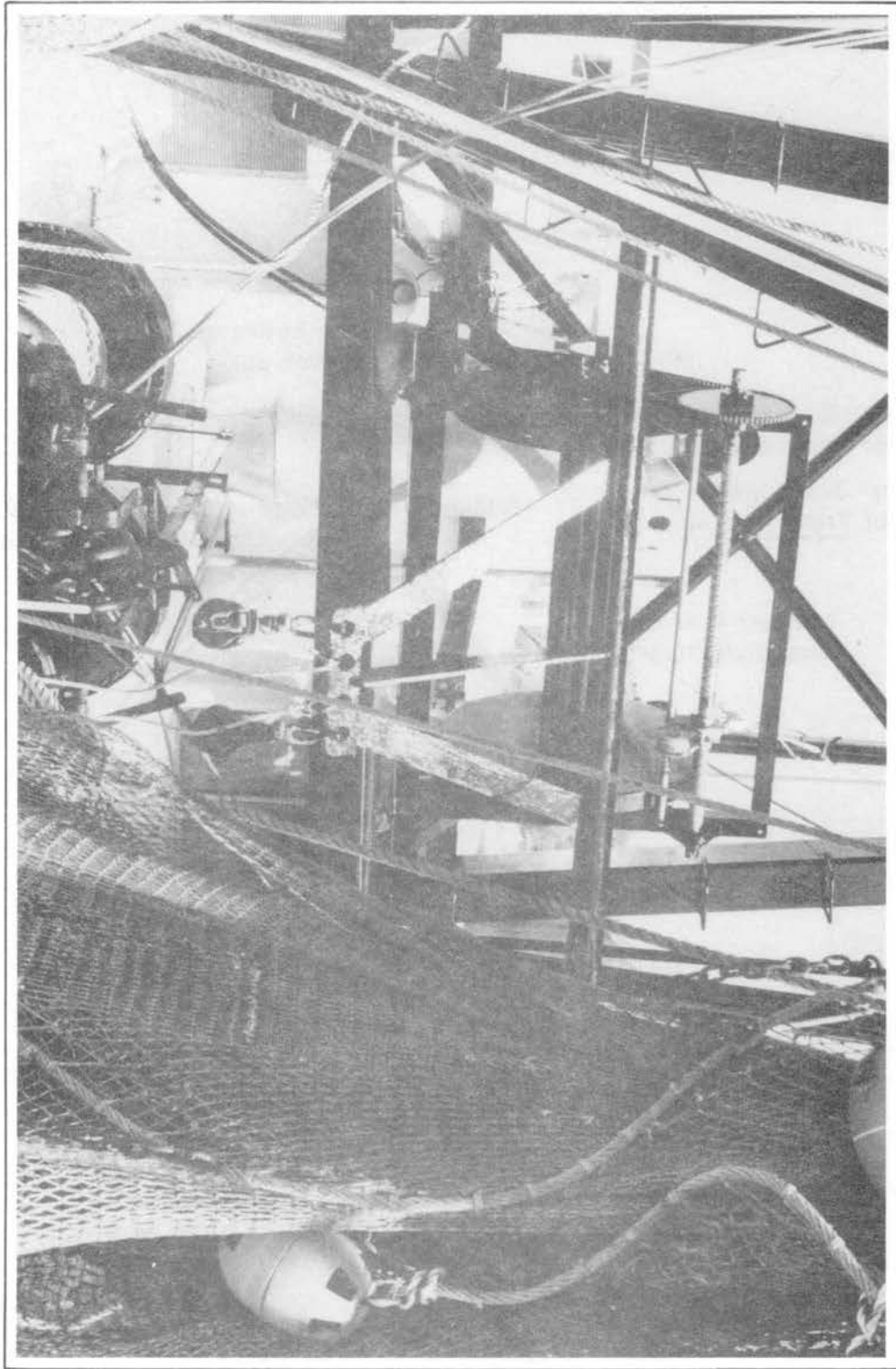

Figure 2. Location of Captain Phillips' longline reel

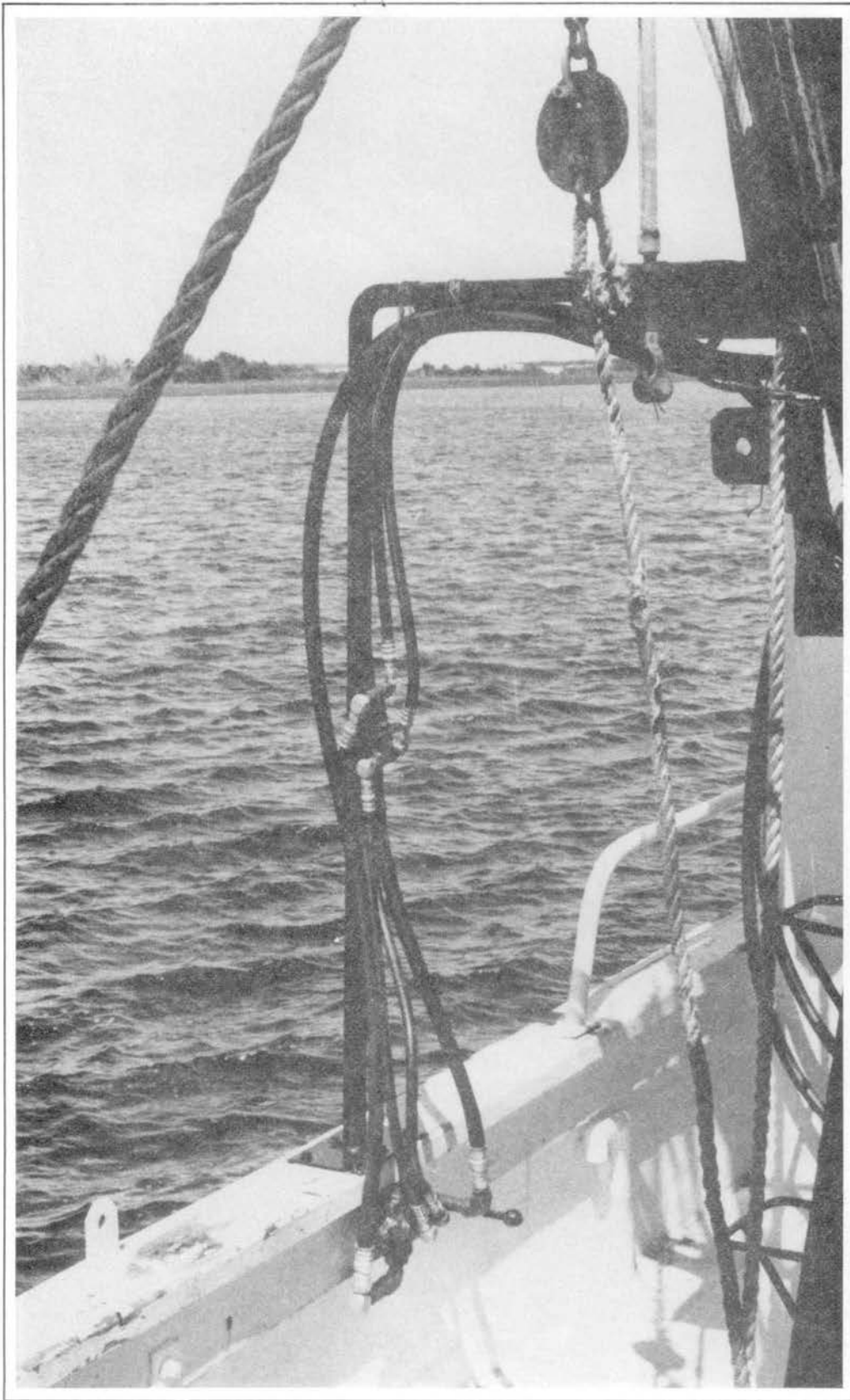

Figure 3. Location of control lever that operates the bottom longline reel



Figure 4. Baiting table used to hold baited snoods before clipping them onto main cable

main line was weighted with 15 pounds of weight and released overboard.

The main line on the longline reel was fair-lead to a block located 8 feet up on the aft ladder, next to a block located just past the caprail on the outrigger, and then back to a stern davit with a quick release open face block. Just past the davit was the snood clipping station where the crew clipped on snoods every 25 to 35 feet as the main line was being powered out. The captain would then steam slowly down current (about 3 knots) over the fishing spot. The main line cable was powered off until enough was out to allow free wheeling (Figure 5).

After the desired number of snoods were attached to the main line, additional cable was released to allow the baited portion of the line to reach the bottom. Meanwhile, the captain would turn into the current. When there was enough slack in the main line, the cable would be slipped out of the stern open face block. The main line was never released from the vessel, and hooks were allowed to soak approximately 45 minutes before the gear was retrieved.

The main line was retrieved at midship through a block attached to the outrigger (Figure 5). The baiting table would be moved from the setting station to the mid-ship retrieval station. Two men operated this station, one retrieving the cable and unclipping the snoods while the other rebaited hooks and helped unclip hooked fish from the main cable. A third or sometimes fourth crew member would be cleaning the decked fish and putting them on ice.

This setting and retrieving procedure as shown in Figure 5 was typical of the bottom longliners involved in this project.

C. Trip information, M/V BLACKBEARD

Captain Phillips made five bottom longlining trips in the spring of 1983 for a total of 16 fishing days. Summary information for these trips is presented in Tables 2 through 4. Catch information, total number of

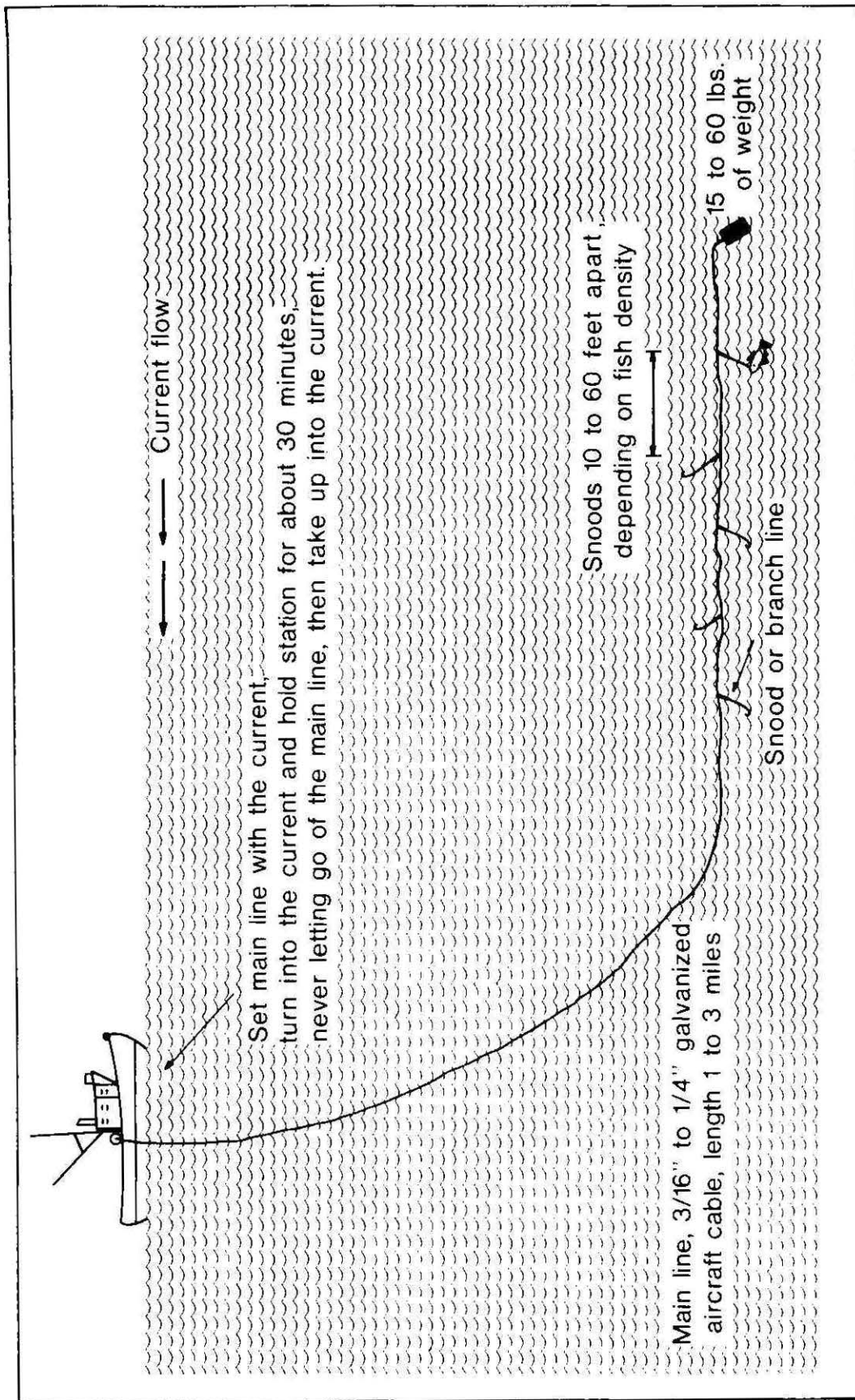

Figure. 5 Generalized hauling and setting procedures

sets, total number of hooks set, and general areas fished are presented by trip number in Table 2. Table 3 summarizes recovery costs and expenses for each trip. Table 4 presents a summary of each trip's packing slips, which include price per pound and markets chosen. A complete summary of the trip logs, which gives Loran C coordinates for all sets, number of hooks, and catch, is in Appendix A.

D. Type of bait used, M/V BLACKBEARD

For bait, Captain Phillips used frozen squid purchased from the Seafood Center, Jacksonville, Florida, at a cost of \$0.69 per pound. Medium-sized squid (6-7 inches) were the favored size bait. Larger-sized squid (over 8 inches) were too big for one hook and had to be cut into sections.

In addition to squid, Captain Phillips tried shrimp by-catch for bait during his fifth trip. The predominant species used were spot and Atlantic croaker. Half of a 6"-8" fish was used per hook. These did not produce as well as the squid. The catch rate using fish for bait was 0.30 pounds per hook, compared to an average rate of 0.87 pounds per hook using squid. However, Captain Phillips did note one benefit of using by-catch for bait: "It was a whole lot cheaper".

E. Problems encountered, M/V BLACKBEARD

A few minor problems were encountered with the bottom longline winch. A new sprocket had to be purchased, for \$62.72, to give the winch greater speed. Another small problem occurred with the star coupler or lovejoy (Figure 6), which connected the hydraulic motor to the longline reel. A new rubber coupler of heavier gauge and strength (Figure 7) had to be purchased at a cost of \$90. With continuous start and stop usage of the bottom longline reel, a heavy duty star coupler is recommended.

On the second trip, poor weather conditions caused Captain Phillips to miss one and a half days of fishing. Other winter storms prevented him from making as many trips as he had intended.

Table 2. Trip summary for the M/V BLACKBEARD, 1983

<u>Trip No.</u>	<u>No. of days fished</u>	<u>Trip dates</u>	<u>No. of sets</u>	<u>No. of hooks set</u>	<u>No. of fish caught</u>	<u>Lbs.¹ of fish caught</u>	<u>Catch per hook (lbs.)</u>	<u>General area fished Loran C</u>
1	2	Apr. 4-7	6	1,641	123	2,029	1.24	45110.0 60810.0
2	4	Apr. 14-18	10	6,478	450	5,281	0.82	45090.0 60800.0
3	2	Apr. 20-23	12	4,792	166	4,229	0.88	45080.0 60770.0
4	5	Apr. 25 - May 1	28	10,759	373	5,913	0.55	45100.0 60810.0
5	3	June 19-23	12	4,643	136	1,379	0.30	45080.0 60780.0
Totals	16		68	28,313	1,248	18,831		

¹ Calculated from the amount of gutted fish sent to market

Table 3. Trip expenses and income generated for the M/V BLACKBEARD (rounded to nearest dollar)

Trip No.	Itemized Trip Expenses						Total trip expenses	Gross income from fish sales	Net trip recovery
	Fuel/Oil	Ice	Bait	Groceries	Packing	Freight			
1	\$ 720	\$100	\$565	\$100	\$ 205	None	\$1,690	\$2,629	(+) \$ 939
2	776	200	Used left-overs from 1st trip	96	660	None	1,733	6,378	(+) 4,645
3	594	75	565	80	507	None	1,821	5,562	(+) 3,741
4	693	100	Used left-overs from 3rd trip	80	711	None	1,583	6,573	(+) 4,990
5	665	125	Used by-catch from shrimping	85	165	None	1,040	1,448	(+) 408
Totals	\$3,448	\$600	\$1,130	\$441	\$2,248		\$7,867	\$22,590	(+) \$14,723

Table 4. Catch summary before packing and freight
for the M/V BLACKBEARD

<u>Trip No.</u>	<u>Catch (lbs.)</u>	<u>Price per pound</u>	<u>Total amount (rounded)</u>	<u>Species & grade</u>	<u>Sold to</u>
1	66	\$0.65	\$ 43	Grey tilefish	Michael's Seafood, Jacksonville, FL
	800	1.30	1,040	Golden tilefish (0-8 lbs.)	"
	341	1.30	443	Golden tilefish (8-12 lbs.)	"
	593	1.30	771	Golden tilefish (12 lbs. +)	"
	<u>229</u>	1.45	<u>332</u>	Snowy grouper	"
Totals	2,029		\$2,629		
2	2,500	\$1.35	\$3,375	Snowy grouper (15 lbs. +)	Cook's Seafood, Murrell Inlet, SC
	670	1.35	905	Snowy grouper (8-15 lbs.)	"
	141	1.35	190	Snowy grouper (0-8 lbs.)	"
	714	1.10	785	Golden tilefish (8-15 lbs.)	"
	1,100	.95	1,045	Golden tilefish (4-8 lbs.)	"
	156	.50	78	Grey tilefish (0-8 lbs.)	"
Totals	5,281		\$6,378		

Table 4. Catch summary before packing and freight
for the M/V BLACKBEARD (cont'd.)

<u>Trip No.</u>	<u>Catch (lbs.)</u>	<u>Price per pound</u>	<u>Total amount (rounded)</u>	<u>Species & grade</u>	<u>Sold to</u>
3	3,709	\$1.35	\$5,007	Snowy grouper	Michael's Seafood, Jacksonville, FL
	404	1.10	444	Golden tilefish (8-12 lbs.)	"
	116	.95	110	Golden tilefish (4-8 lbs.)	"
Totals	<u>4,229</u>		<u>\$5,561</u>		
4	240	\$0.80	\$ 192	Golden tilefish (6-8 lbs.)	Cook's Seafood, Murrell Inlet, SC
	1,421	.90	1,279	Golden tilefish (8 lbs. +)	"
	4,252	1.20	5,102	Snowy grouper (mixed sizes)	"
Totals	<u>5,913</u>		<u>\$6,573</u>		
5	716	\$1.05	\$ 752	Snowy grouper (0-8 lbs.)	Cook's Seafood, Murrell Inlet, SC
	200	1.10	220	Snowy grouper (8 lbs. +)	"
	101	.95	96	Golden tilefish (0-8 lbs.)	"
	362	1.05	380	Golden tilefish (8 lbs. +)	"
Totals	<u>1,379</u>		<u>\$1,448</u>		

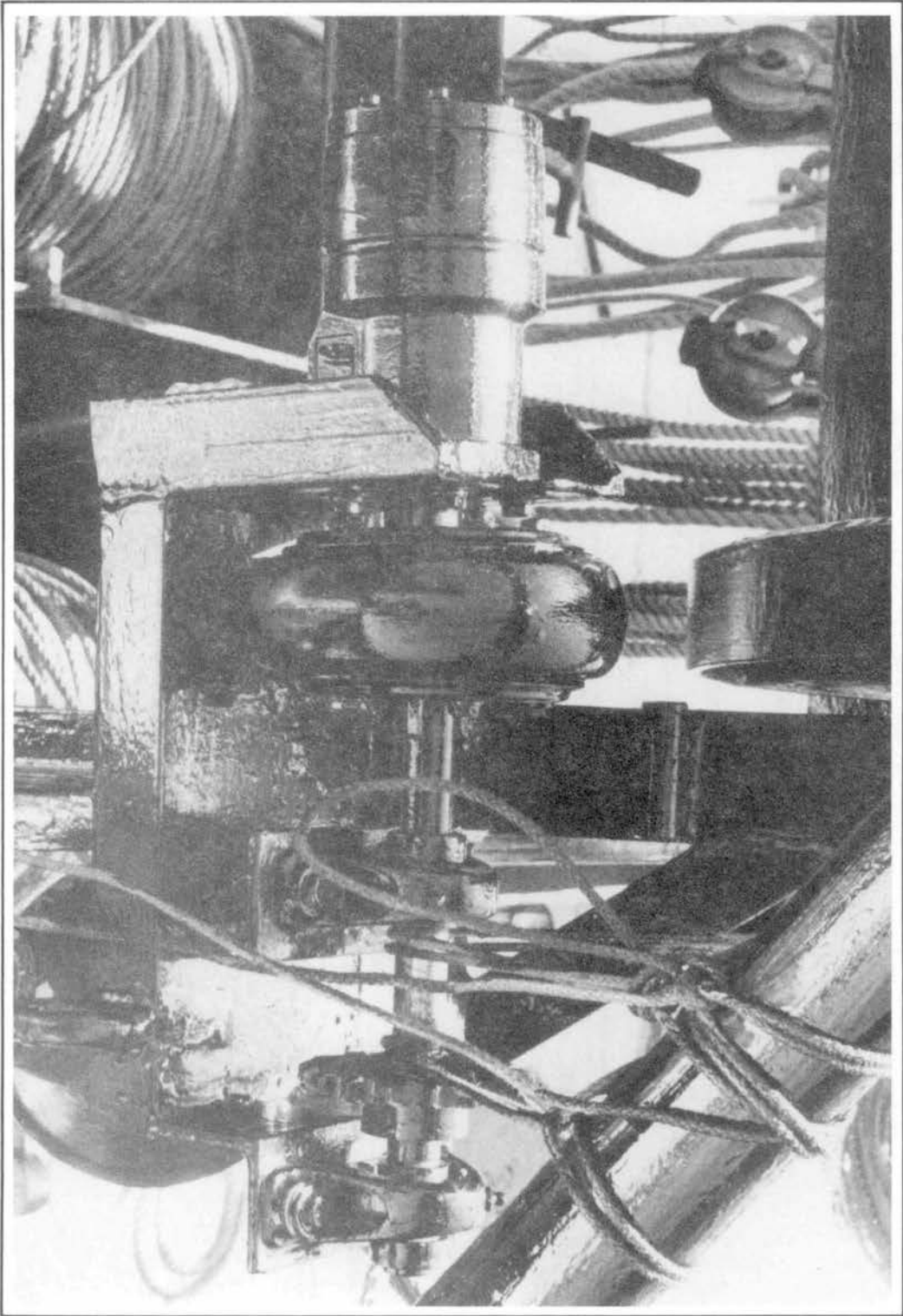

Figure 6. Star coupler or lovejoy connector, originally purchased

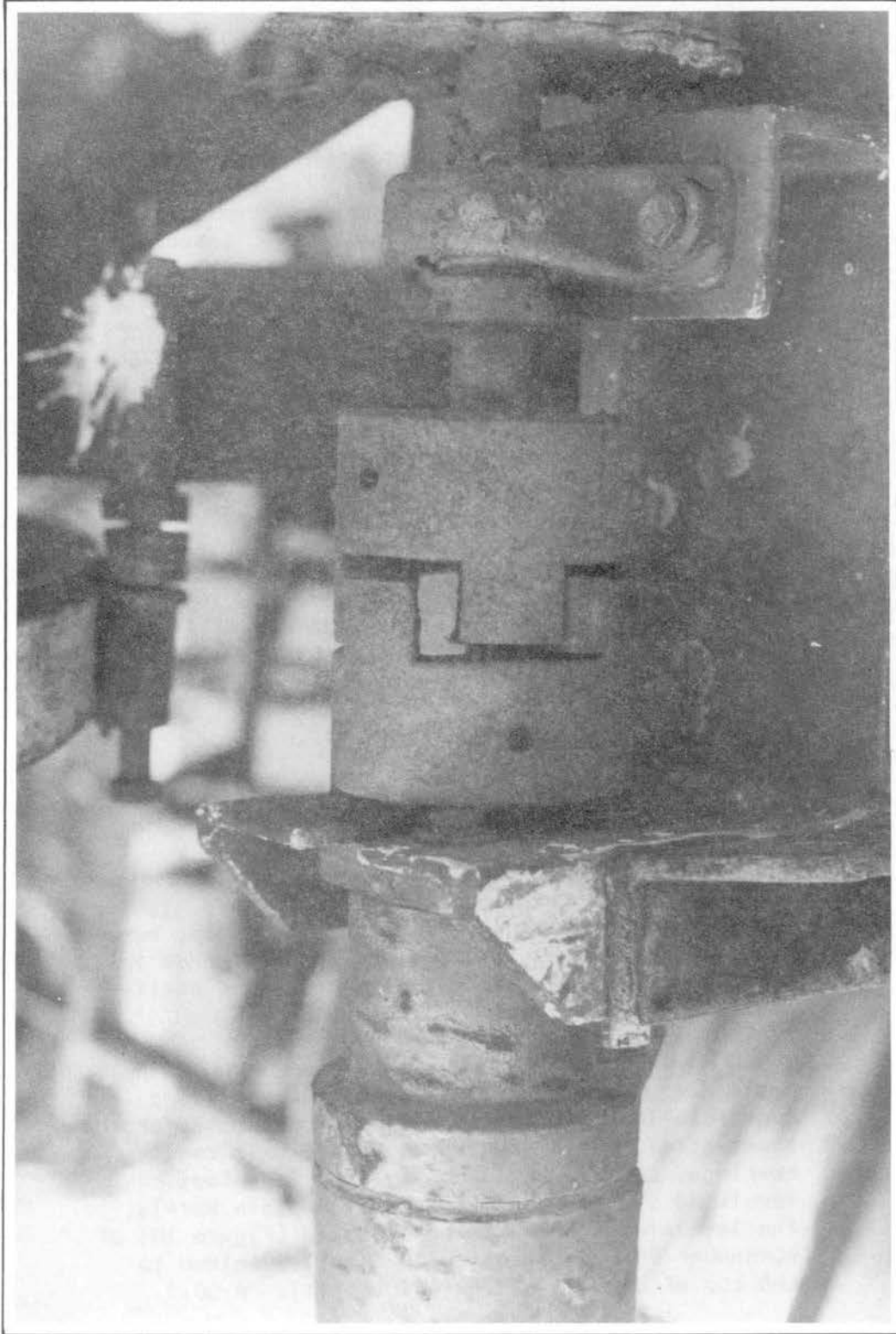

Figure 7. Replacement star coupler or lovejoy of heavier, stronger construction

II. BOTTOM LONGLINING - M/V CREDIT - Captain Roy Purvis

A. Conversion expenses for the M/V CREDIT

1. Longline reel: With the help of a local welder, Captain Roy Purvis built his longline reel. He bought the parts for the hydraulic system for \$1,502.79, assembled and installed it. Labor costs paid to the welder were \$350. The total cost for his hydraulic powered longline reel was \$1,852.79. For an itemized breakdown of expenses, see Table 5.
2. Bottom longline cable: 16,000 feet of 7/32" used galvanized electrode cable was purchased from Dawson Pipe and Cable Co., Portland, Texas, at a cost of \$577.50 plus shipping costs of \$173.85, for a total of \$751.35.
3. Branch lines or snoods: Materials for construction of 1,200 snoods were purchased from Jacksonville Fishermen's Supply, Jacksonville, Florida, at a cost of \$1,706.94. Figure 8 shows Captain Purvis' snood design.
4. Total conversion costs: \$4,311.08.

B. Description and method of deployment gear for the M/V CREDIT

1. Location of reel: Captain Roy Purvis mounted his longline reel like Captain Phillips (Figure 9), just above the main winches, aft of the wheelhouse between the A-frame design pipe rigging. He preferred this location because it was out of the way and easily accessible for repair.
2. Description of longline reel and levelwind: The basic design of the reel is similar to existing commercially built units. It was constructed of sheet steel, angle iron, steel pipe, axle rod, bearings, chain, and sprockets. An ingenious levelwind system was developed by Captain Purvis. The levelwind system was constructed (Figure 10) of RC-Number 80 width chain with a swivel welded to the top of one chain link (Figure 11). A 60:1

Table 5. Expenditures from the addition of a bottom longline reel to the M/V CREDIT

Materials for longline reel and hydraulic tank	\$ 750.00
Chain, valves, seals, bearings, sprockets, etc.	350.87
Paint (rust-resistant)	41.88
Hydraulic fluid	40.04
Hoses and hydraulic pipe	320.00
Labor for welding	<u>350.00</u>
Total	\$1,852.79

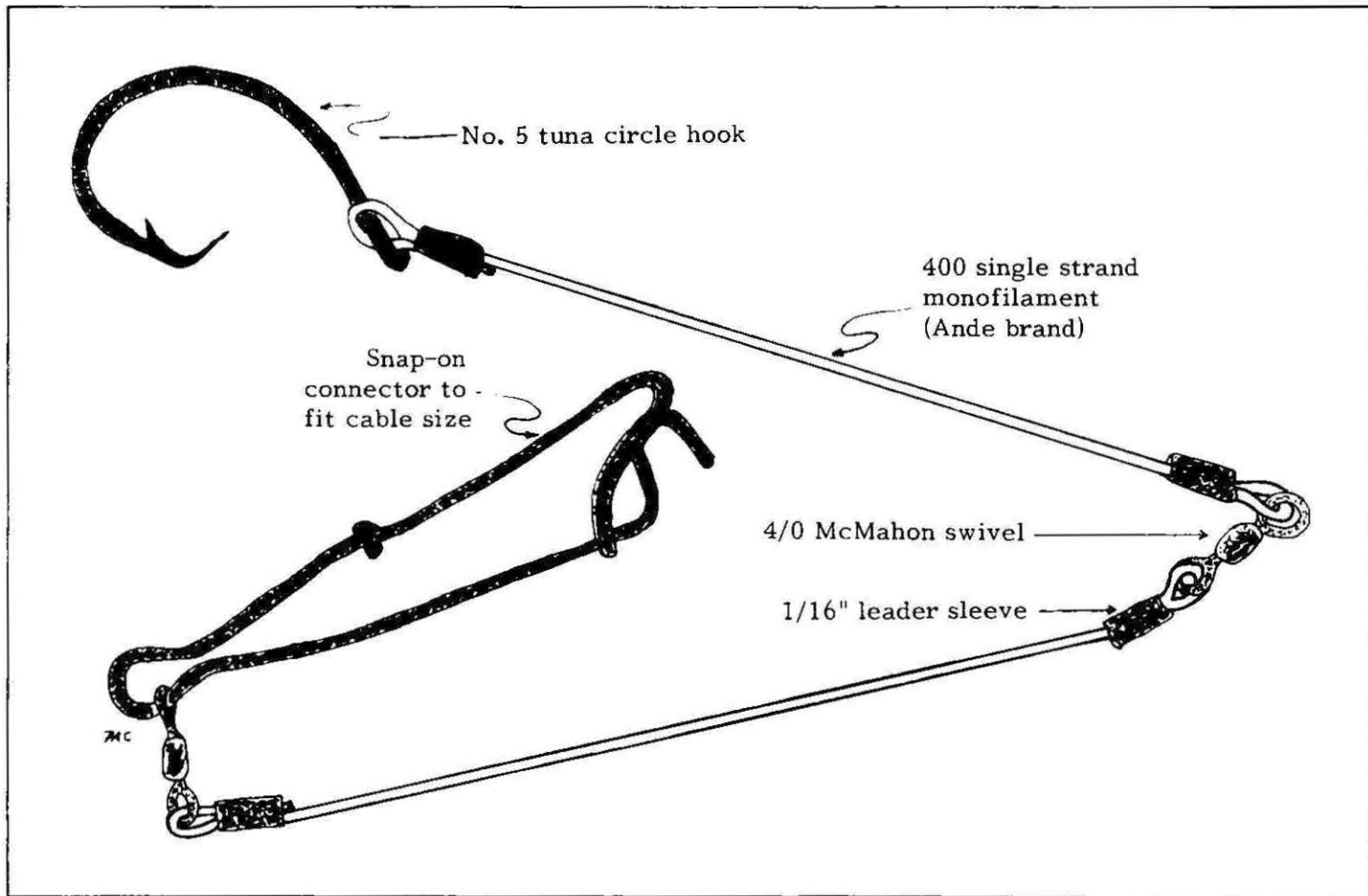

Figure 8. Snood design used by Captain Roy Purvis

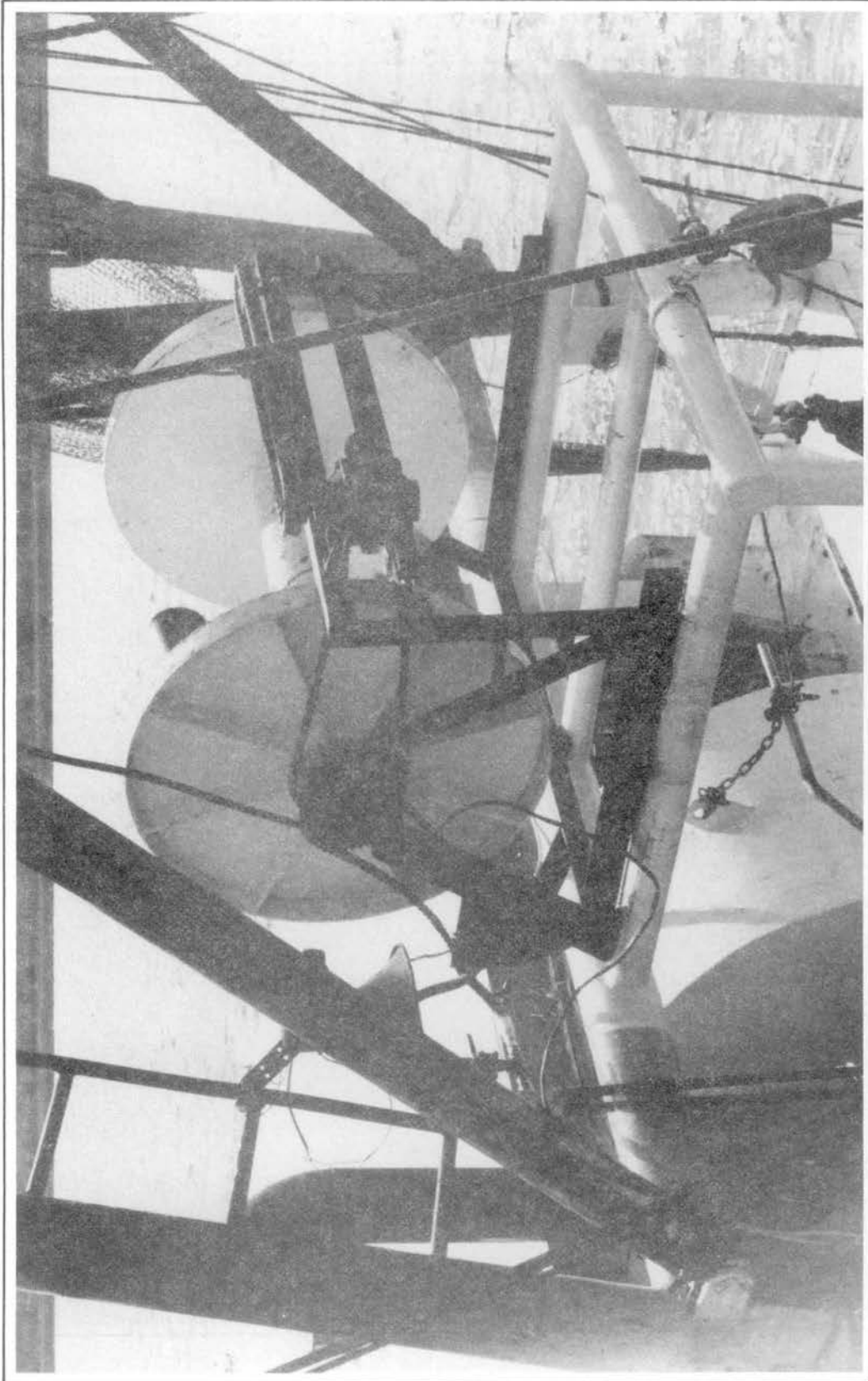

Figure 9. Location of Captain Roy Purvis' longline reel

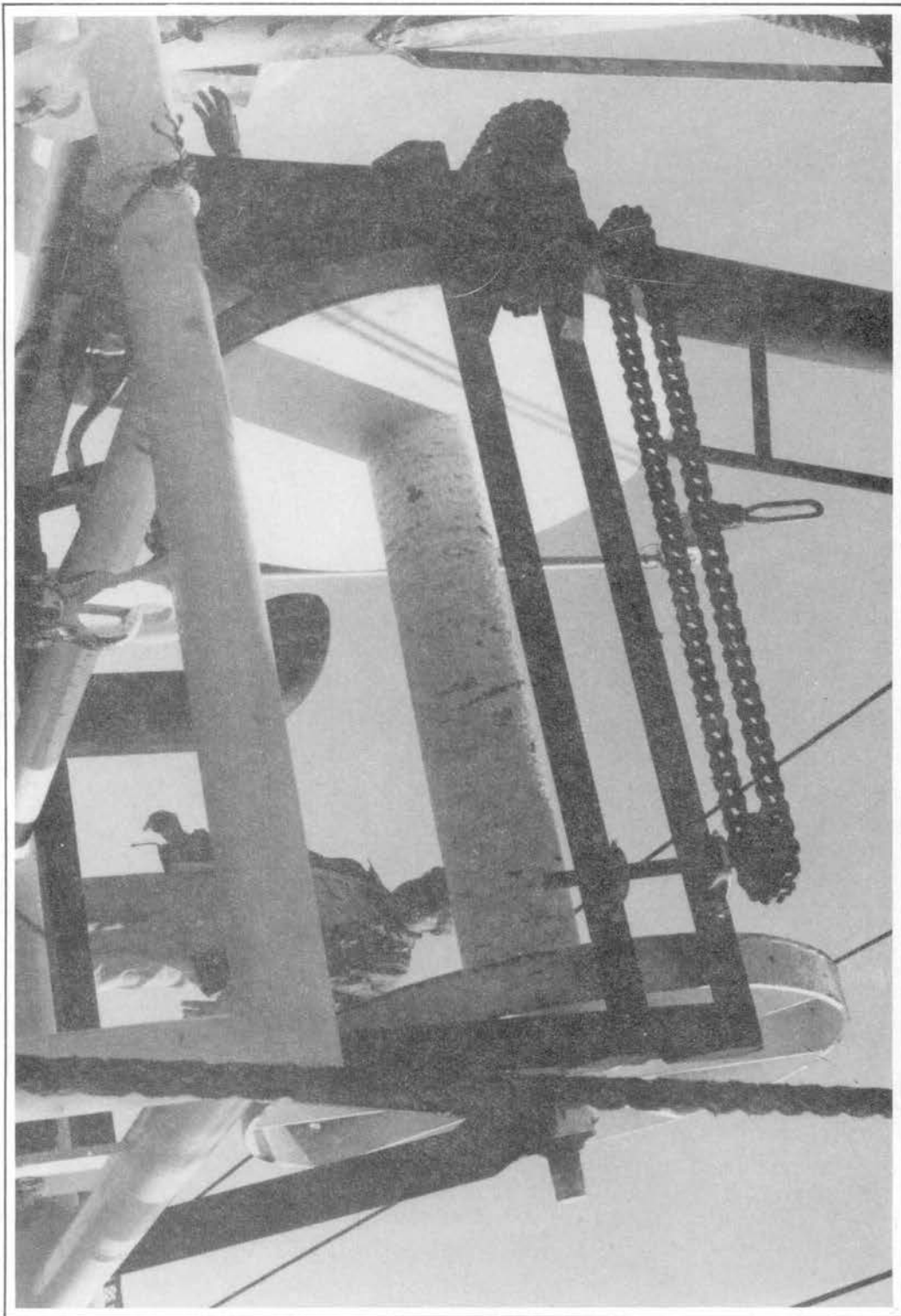

Figure 10. Longline reel from the M/V CREDIT showing homemade chain-driven levelwind

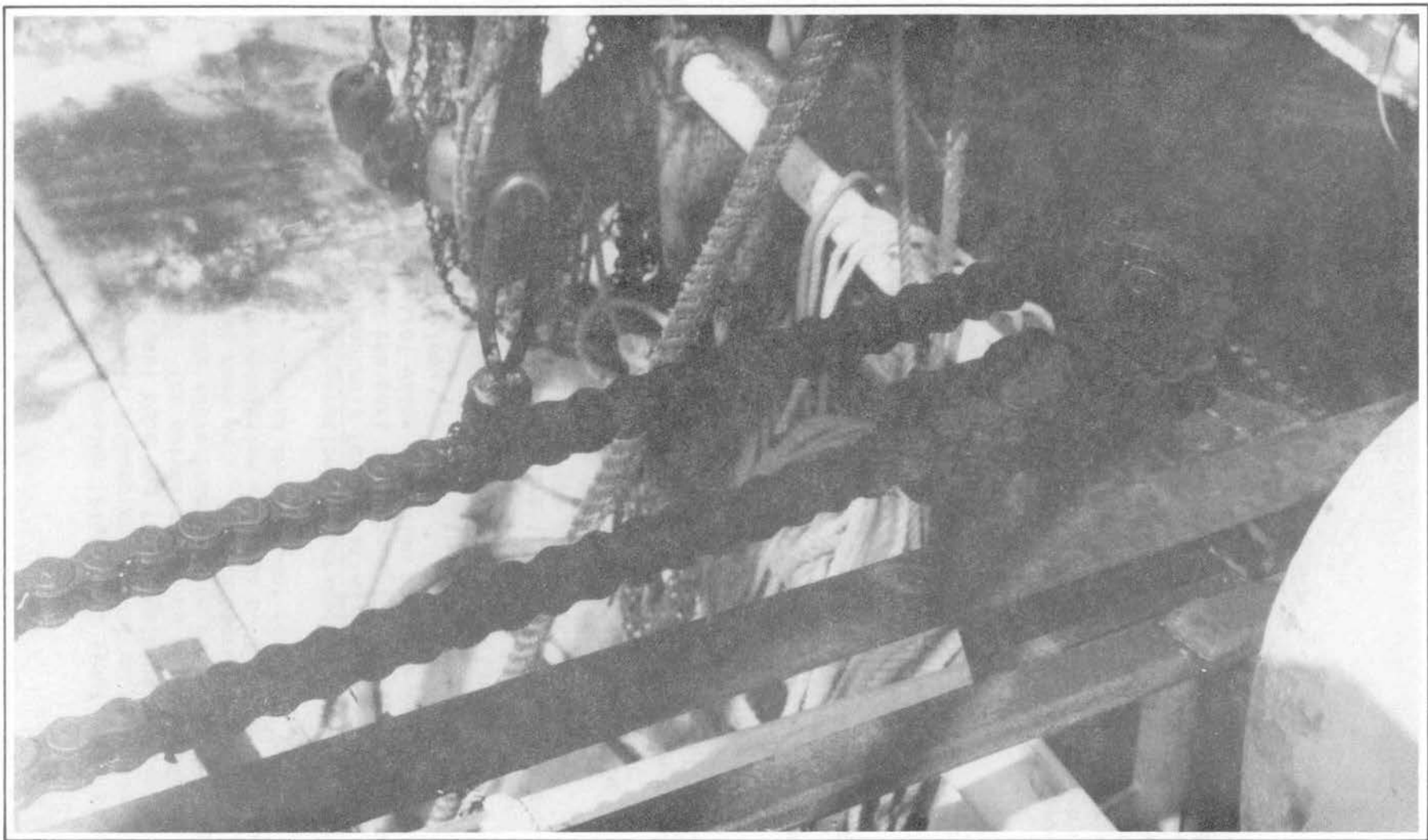

Figure 11. Detail of swivel guide welded to the top of one chain link, M/V CREDIT

reduction transmission (Figure 12) slowly propelled the chain. This allowed the swivel action cable guide to travel back and forth, guiding the cable as it moved. The swiveling action of the cable guide kept the cable from binding as it rounded the sprockets at each end. The winch drum and the reduction transmission were run by a hydraulic motor (Figure 12) mounted on the spool frame.

3. Location and operation of hydraulic controls: The hydraulic controls for operating the winch were mounted on the port side about 15 feet back from the bow. Control valve operation was done by the operator's leg.
4. Setting and retrieving operations: Setting and retrieving procedures of the bottom longline gear on the M/V CREDIT (Figure 13) were essentially the same as described for the M/V BLACKBEARD.

Fairleading the main line cable on the M/V CREDIT was done somewhat differently, however. Instead of hauling back off the outrigger, Captain Roy Purvis mounted a davit on the port bow quarter. When setting out, the cable doubled back from the bow station to a davit at the port stern quarter, which was equipped with an open face block. Take up procedures were similar to those used by Captain Phillips, except that the retrieval station was at the port bow quarter. Captain Purvis felt he could control his boat better and take up more directly over the cable with the retrieval station located forward.

C. Trip information, M/V CREDIT

Six bottom longlining trips were made on the M/V CREDIT for a total of 18 fishing days. Summary information for these trips is presented in Tables 6 through 8. Catch information, total number of sets, total number of hooks set, and general areas fished are presented by trip number in Table 6. Trip recovery and expenses for each trip are summarized in Table 7. Table 8 gives a summary of the packing slips for each trip and the markets chosen. A summary of Captain Roy Purvis' logs is in Appendix B.

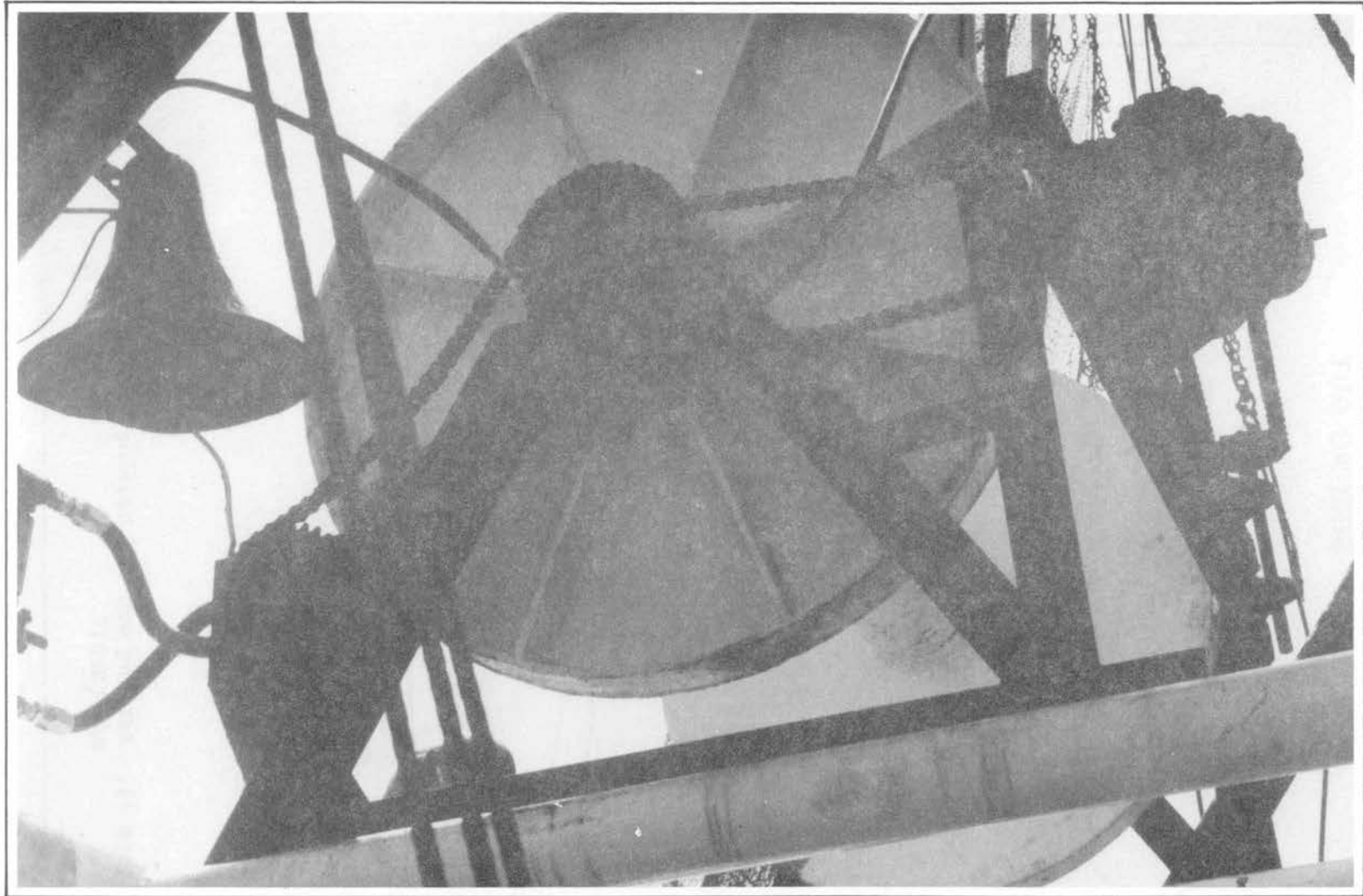

Figure 12. Detail of hydraulic motor drive systems and 60:1 reduction transmission,
M/V CREDIT

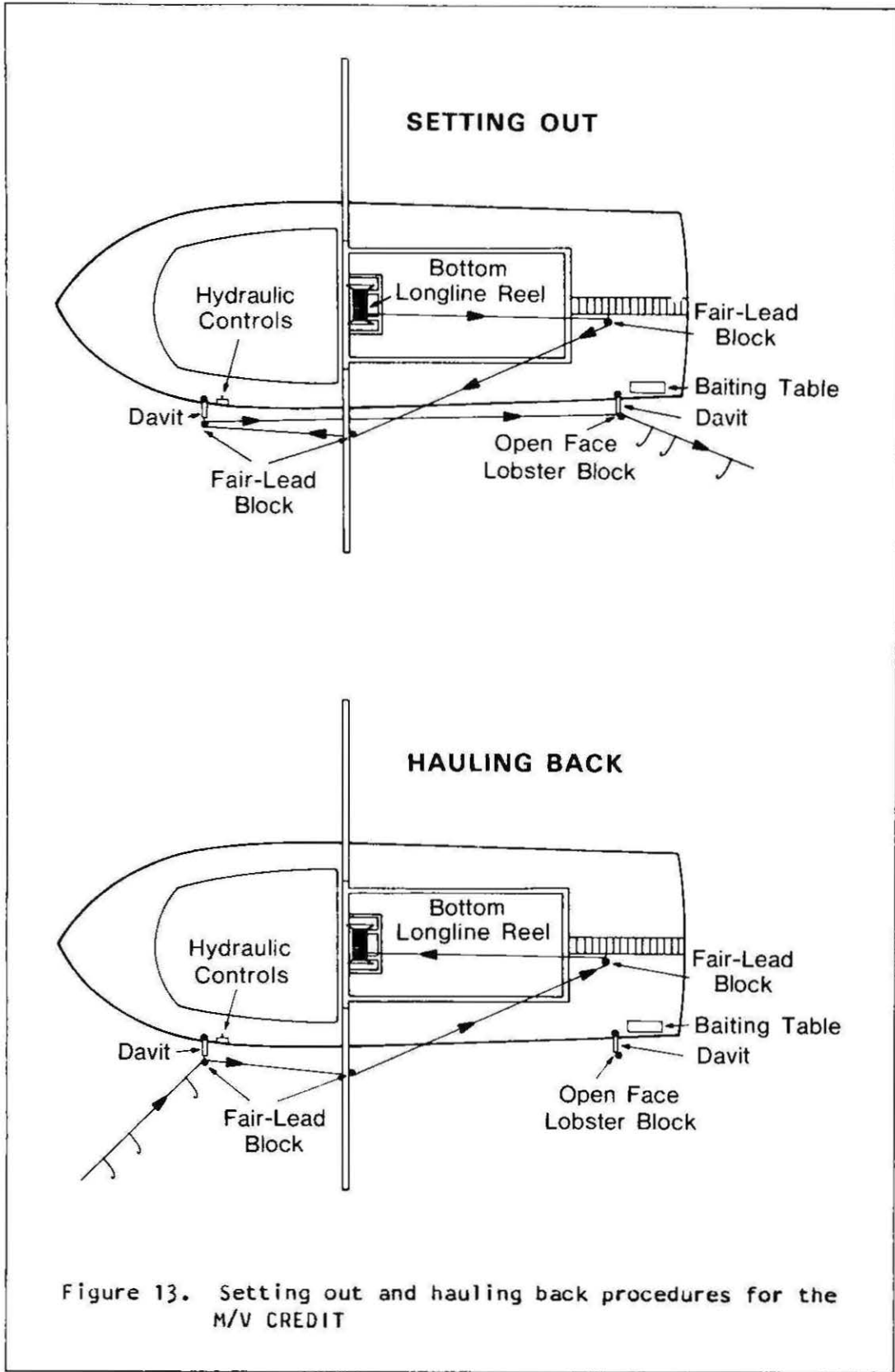

Table 6. Trip summary for the M/V CREDIT, 1983

Trip No.	No. of days fished	Trip dates	No. of sets	No. of hooks set	No. of fish caught	Lbs. ¹ of fish caught	Catch per hook (lbs.)	General area fished Loran C
1	1	Mar. 14-16	3	1,309	82	673	0.51	45100.0 60800.0
2	3	Mar. 27-31	14	7,911	348	2,091	0.26	45100.0 60800.0
3	4	Apr. 4-9	13	8,825	483	3,608	0.41	45090.0 60750.0
4	3	Apr. 12-16	8	6,300	309	2,163	0.34	45100.0 60800.0
5	3	Apr. 19-23	11	7,945	227	1,550	0.20	45095.0 60700.0
6	4	Apr. 26 - May 1	25	11,939	263	1,752	0.15	45100.0 60850.0
Totals	18		74	44,229	1,712	11,837		

¹ Calculated from the amount of gutted fish sent to market

Table 7. Trip expenses and income generated for the
M/V CREDIT (rounded to nearest dollar)

Trip No.	Itemized Trip Expenses						Total trip expenses	Gross income from fish sales	Net trip recovery
	Fuel/Oil	Ice	Bait	Groceries	Packing	Freight			
1	\$ 768	\$140	N/C	\$ 60	None	None	\$ 968	\$ 995	(+) \$ 27
2	None	49	N/C	80	None	21	150	3,090	(+) 2,940
3	980	150	346	100	46	None	1,622	4,946	(+) 3,324
4	980	150	N/C	130	61	165	1,486	2,133	(+) 647
5	None	150	N/C	115	None	None	265	1,520	(+) 1,255
6	985	None	346	80	None	None	1,411	1,768	(+) 357
Totals	\$3,713	\$639	\$692	\$565	\$107	\$186	\$5,902	\$14,452	(+) \$8,550

Table 8. Catch summary before packing and freight
for the M/V CREDIT

Trip No.	Catch (lbs.)	Price per pound	Total amount (rounded)	Species & grade	Sold to
1	96	\$1.80	\$ 173	Snowy grouper	Captain's Table Restaurant, Brunswick, GA
	85	.90	77	Grey tilefish	
	<u>181</u>		<u>250</u>		
	186	1.80	335	Snowy grouper	
	150	1.80	270	Snowy grouper	Jekyll Seafood, Jekyll Island, GA
	152	.90	137	Grey tilefish	
	4	1.50	6	Yellowfin grouper	
	<u>306</u>		<u>413</u>		
Totals	673		\$ 998		
<hr/>					
2	190	\$0.90	\$ 171	Golden tilefish (0-8 lbs.)	Behrens Seafood, New York, NY
	896	1.90	1,702	Snowy grouper	Jimmy's Seafood, Brunswick, GA
	<u>781</u>	1.00	<u>781</u>	Golden tilefish	
	<u>1,677</u>		<u>2,483</u>		
	102	2.00	204	Golden tilefish	Jekyll Seafood, Jekyll Island, GA
	<u>122</u>	1.90	<u>232</u>	Snowy grouper	
	<u>224</u>		<u>436</u>		
Totals	2,091		\$3,090		

Table 8. Catch summary before packing and freight
for the M/V CREDIT (cont'd.)

<u>Trip No.</u>	<u>Catch (lbs.)</u>	<u>Price per pound</u>	<u>Total amount (rounded)</u>	<u>Species & grade</u>	<u>Sold to</u>
3	2,218	\$1.30	\$2,883	Golden tilefish (8 lbs. +)	McCoy Brothers Seafood, Jacksonville, FL
	1,316	1.50	1,974	Snowy grouper (8 lbs. +)	Jimmy's Seafood, Brunswick, GA
	74	1.20	89	Grey tilefish	
	<u>1,390</u>		<u>2,063</u>		
Totals	3,608		\$4,946		
<hr/>					
4	640	\$1.00	\$ 640	Golden tilefish (8 lbs. +)	M. Slavin & Sons, LTD. New York, NY
	859	.85	730	Golden tilefish (0-8 lbs.)	
	<u>1,499</u>		<u>1,370</u>		
	127	1.20	153	Golden tilefish	Captain's Table Restaurant, Brunswick, GA
	200	1.45	291	Golden tilefish	Jekyll Seafood, Jekyll Island, GA
	140	1.30	182	Snowy grouper	Jimmy's Seafood, Brunswick, GA
	197	.70	138	Grey tilefish	
	<u>337</u>		<u>320</u>		
Totals	2,163		\$2,134		

Table 8. Catch summary before packing and freight
for the M/V CREDIT (cont'd.)

<u>Trip No.</u>	<u>Catch (lbs.)</u>	<u>Price per pound</u>	<u>Total amount (rounded)</u>	<u>Species & grade</u>	<u>Sold to</u>
5	158	\$1.20	\$ 190	Golden tilefish (8 lbs. +)	Feger's Seafood Co., New Smyrna Beach, FL
	38	1.20	46	Golden tilefish (0-8 lbs.)	
	<u>196</u>		<u>236</u>		
	1,050	.85	893	Golden tilefish	Jimmy's Seafood, Brunswick, GA
	29	.60	17	Grey tilefish	
	<u>1,079</u>		<u>910</u>		
	100	1.50	150	Snowy grouper	Jekyll Seafood, Jekyll Island, GA
	50	2.00	100	Golden tilefish	Lester Drawdy, Jr., Brunswick, GA
	125	1.00	125	Golden tilefish	Captain's Table Restaurant, Brunswick, GA
Totals	<u>1,550</u>		<u>\$1,521</u>		
6	823	\$0.85	\$ 700	Golden tilefish	Jimmy's Seafood, Brunswick, GA
	929	1.15	1,068	Snowy grouper	
Totals	<u>1,752</u>		<u>\$1,768</u>		

It contains the following information on a set basis: Loran C coordinates, number of hooks fished, and catch.

D. Type of bait used, M/V CREDIT

Captain Roy Purvis experimented with different types of bait. He felt squid was the best bait, but rather expensive. On his fourth trip, 300 pounds of shark cut into chunks about 5" x 3" x 3" were tried. This was considered an excellent bait but created much work for the crew. On his fifth trip, buck shad was tried. The fish was cut into strips about the same size as the shark and soaked in brine to toughen the flesh. The results were poor because the fish was too soft and fell off the hook. Captain Purvis concluded that squid and shark were the best bottom longline baits.

E. Problems encountered, M/V CREDIT

The main problems were bad weather and damage to the vessel. On the fifth trip, the weather was so severe that it broke out two wheelhouse windows, tore off one stabilizer, an anchor, and 1,000 feet of anchor line. The only other non-weather-related repair was to replace the hydraulic drive motor on the bottom longline winch. The new motor cost \$250. Total repair costs attributed to bottom longlining for the M/V CREDIT were estimated at \$800.

III. BOTTOM LONGLINING - M/V WAR HORSE - Captain Raleigh Purvis

A. Conversion expenses for the M/V WAR HORSE

1. Longline reel: Captain Raleigh Purvis borrowed a used longline reel with an estimated value of \$800. This reel was a typical surface longline reel with no levelwind and was geared for speed, not power. Therefore, the gear ratio was reduced to provide more power. Captain Purvis spent approximately \$500 modifying the reel. These expenses included a new hydraulic motor, gears, sprockets, and chain.
2. Hydraulic set-up: Pipes, main drive pump, drive system, belts, hydraulic lines, fluid reservoir tank,

valves, and labor for the welder to install the pump bracket cost \$1,300.

3. Bottom longline cable: 16,000 feet of 3/16" cable with stops every 20 feet was borrowed. Value of the cable was \$1,280.
4. Branch lines or snoods: 800 snoods were borrowed. If purchased, these would have cost approximately \$1,000.
5. Miscellaneous expenses: Various blocks and extra parts for the hydraulic system were estimated by Captain Purvis to be \$200.
6. Total conversion costs: \$2,000 plus \$3,080 for the borrowed gear, for a total of \$5,080.

B. Description and methods of gear deployment for the M/V WAR HORSE

1. Location of reel: The longline reel was mounted directly over the entrance to the ice hold. Captain Purvis stated that it was much easier to mount the reel on deck, and he felt safer with the reel closer to the vessel's center of buoyancy.
2. Location and operations of the hydraulic controls and setting and retrieving operations: Captain Raleigh Purvis set up his boat similar to Captain Roy Purvis' rig. Setting and retrieving operations and location of hydraulic controls were essentially the same as for the M/V CREDIT.

C. Trip information, M/V WAR HORSE

Captain Raleigh Purvis made only two bottom longline trips in the spring of 1983. Summary information for the above two trips is presented in Tables 9 and 10. Catch information, total number of sets, total number of hooks set, and general areas fished are presented by trip number in Table 9. Table 10 presents a summary of the packing slips and the markets chosen. Trip logs for Captain Raleigh Purvis' two bottom longline trips are presented in Appendix C.

Table 9. Trip summary for the M/V WAR HORSE, 1983

<u>Trip No.</u>	<u>No. of days fished</u>	<u>Trip dates</u>	<u>No. of sets</u>	<u>No. of hooks set</u>	<u>Lbs.¹ of fish caught</u>	<u>Catch per hook (lbs.)</u>	<u>General area fished Loran C</u>
1	1	Apr. 19-21	3	1,100	600	0.55	Between 45088-45095, No Loran 60 chain information given.
2	3	Apr. 26-30	10	3,000	1,310	0.44	45100.0 60850.0
Totals	4		13	4,100	1,910		

¹ Calculated from the amount of gutted fish sent to market

Table 10. Catch summary before packing and freight
for the M/V WAR HORSE

<u>Trip No.</u>	<u>Catch (lbs.)</u>	<u>Price per pound</u>	<u>Total amount (rounded)</u>	<u>Species & grade</u>	<u>Sold to</u>
1	200	\$1.00	\$ 200	Grey tilefish	Feger's Seafood Co., New Smyrna Beach, FL
	<u>400</u>	1.25	<u>500</u>	Golden tilefish	"
Totals	600		\$ 700		
<hr/>					
2	1,200	\$1.18	\$1,416	Snowy grouper	Jimmy's Seafood, Brunswick, GA
	<u>110</u>	.80	<u>88</u>	Grey tilefish	"
Totals	1,310		\$1,504		

D. Type of bait used, M/V WAR HORSE

Captain Raleigh Purvis tried squid, shark pieces, and salted buck shad. After the second trip, he felt squid and shark were the best bait and were approximately equal in catch effort.

E. Problems encountered, M/V WAR HORSE

On trip number one, a \$3.50 seal in his main hydraulic drive engine blew out. He did not have a spare seal on the boat, nor did anyone within a 90-mile radius. After the trip, he stocked up with spare parts. No problems arose on his second trip.

IV. FISH TRAWLING - M/V PO BOY - Captain Joe Webster

Captain Joe Webster's part in the project was strictly experimental. He tested the feasibility of towing a fish trawl with a rock hopper sweep (Figure 14), with bracket-mounted shrimp trawl doors, off one outrigger.

A. Conversion expenses for the M/V PO BOY

1. Outrigger supports: Four additional staywires were added to the outriggers for support, two from the bow to the center of the outriggers and two from the mast to the center of the outriggers. All four stays were made from 3/4" galvanized rod attached by a 1" turnbuckle and 3/4" galvanized shackle. Total cost for four stays was \$251.40.
2. Tow block: A 10-ton towing block was mounted midway the length of the outrigger. The cost of the block was \$300.
3. Chafing plates: These were added to the stern of the boat to keep the tow cable from rubbing against the stern caprail while turning. The cost of these chafing plates, constructed of stainless steel, was estimated at \$50.
4. Trawl doors: Two standard 10' x 44" wooden shrimp doors were modified by adding a bracket constructed of 1-1/2" cold rolled black iron rod and 1/2" plate

ROCK HOPPER TRAWLING GEAR

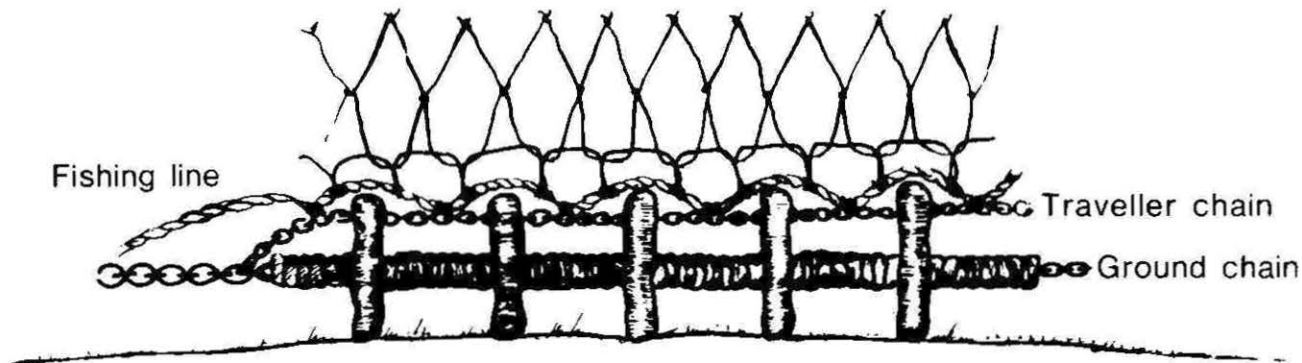

-39-

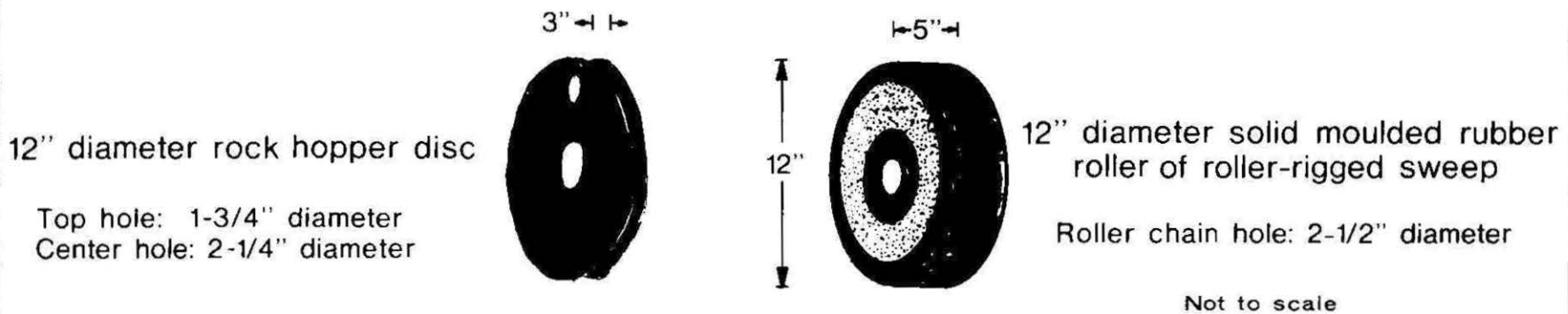

Figure 14. Diagram comparing rock hopper sweep to a roller-rigged sweep

steel (Figure 15). Total cost for modifying two doors was \$160 with no labor cost added.

5. Bridles: Three 300-foot bridles of 1/2" cable were made up at a cost of \$691.82.
6. Nets: Captain Webster fished with two experimental nets provided by the University of Georgia. The nets were a 4-seam high opening fish trawl (Figure 16) and a mongoose fish trawl (Figure 17), each rock hopper-rigged. Specifications for the 4-seam net are as follows:

- a. Four-seam high opening fish trawl

Headrope: 1 length, 7/8" diameter, 3-strand poly-dac rope, 65' long, with permanent markings at quarters (22-1/2' + 20' + 22-1/2').

Hangings: Dog ears at 6-3/4" ties, Bosom meshes at 5-1/2" ties.

Fishing line: 1 length, 5/8" diameter, 3-strand poly-dac line, 90' long (17' + 17' + 22' + 17' + 17'), with permanent markings at quarters and mid-wing.

Wingrope: 1 length, 3-strand poly-dac rope, 18' long.

Hangings: Dog ears at 6-3/4", Bosom meshes at 6" ties.

Roller wires: 5 sections of 3/8" diameter "Trawlex" chain. Two wing sections (15' each) and 1-bosom section (20') totaling 80' overall. All sections were completely covered with 4" diameter rubber discs (cookies) and hanging chains spaced at 24" apart.

Floats: 25-8" diameter plastic floats.

Bridles: Top - 30' long, 3/8" diameter wire, bottom - 30' long, 1/2" diameter wire.

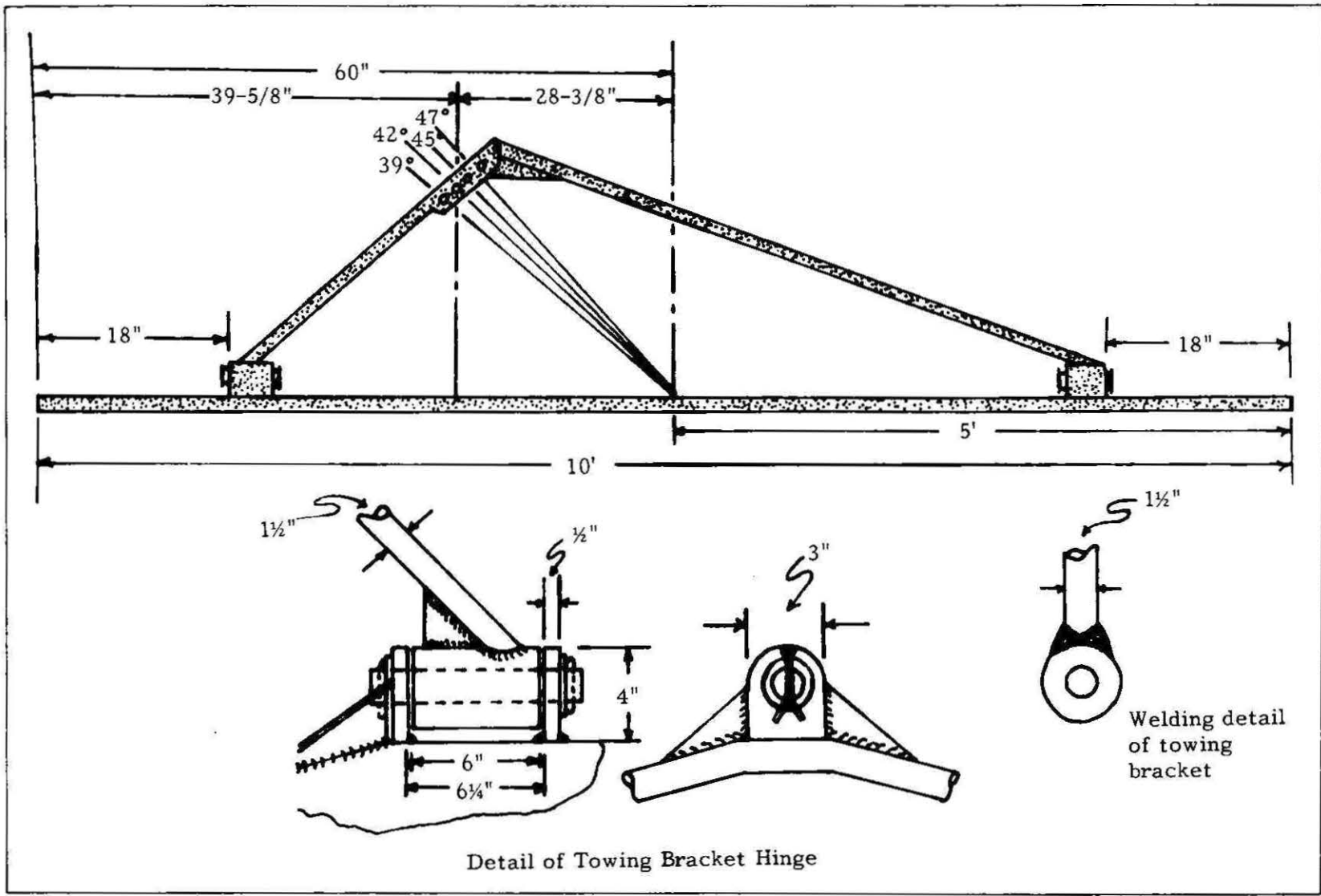

Figure 15. Diagram of bracket used on 10-foot wooden shrimp doors by Captain Joe Webster

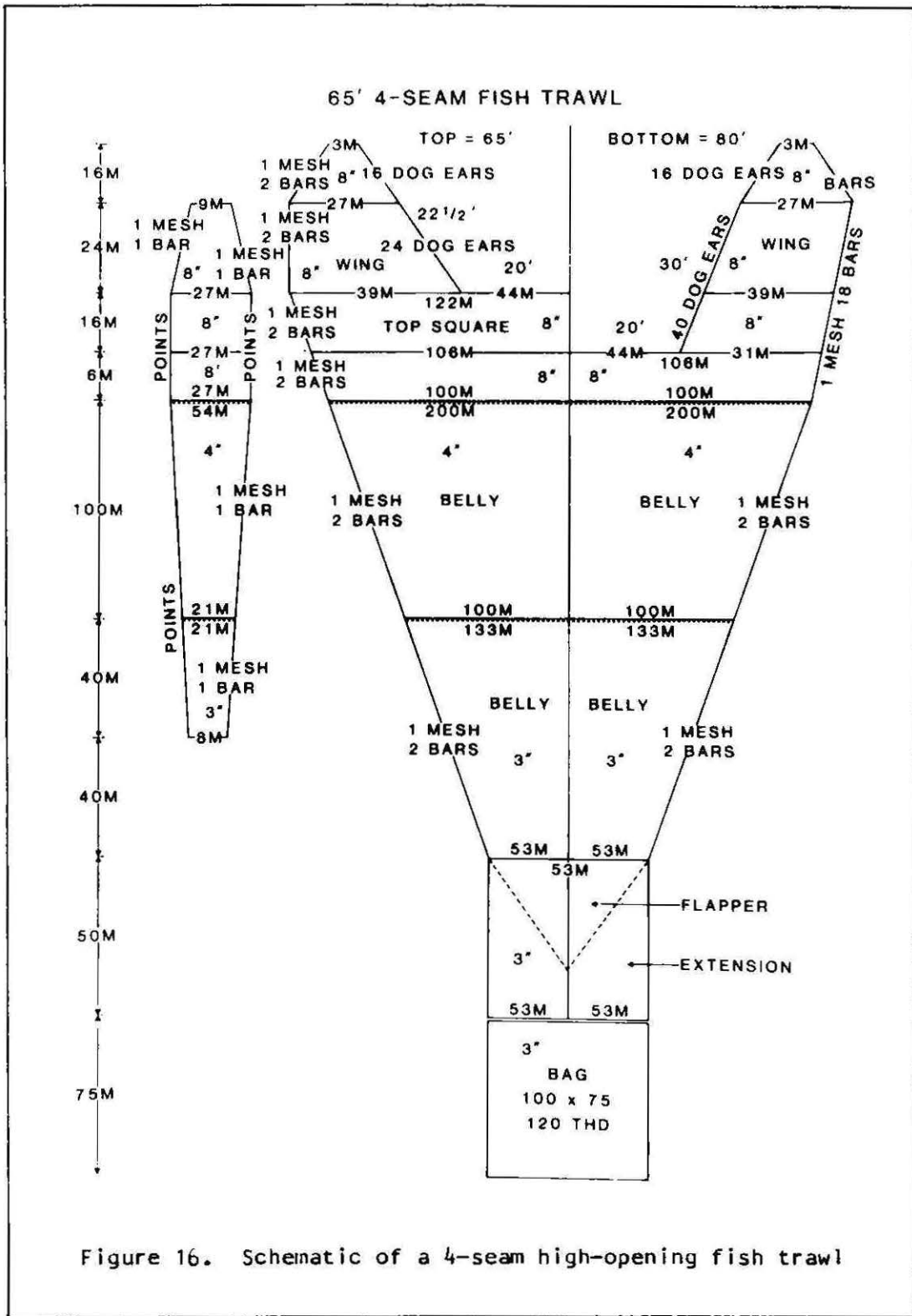

Figure 16. Schematic of a 4-seam high-opening fish trawl

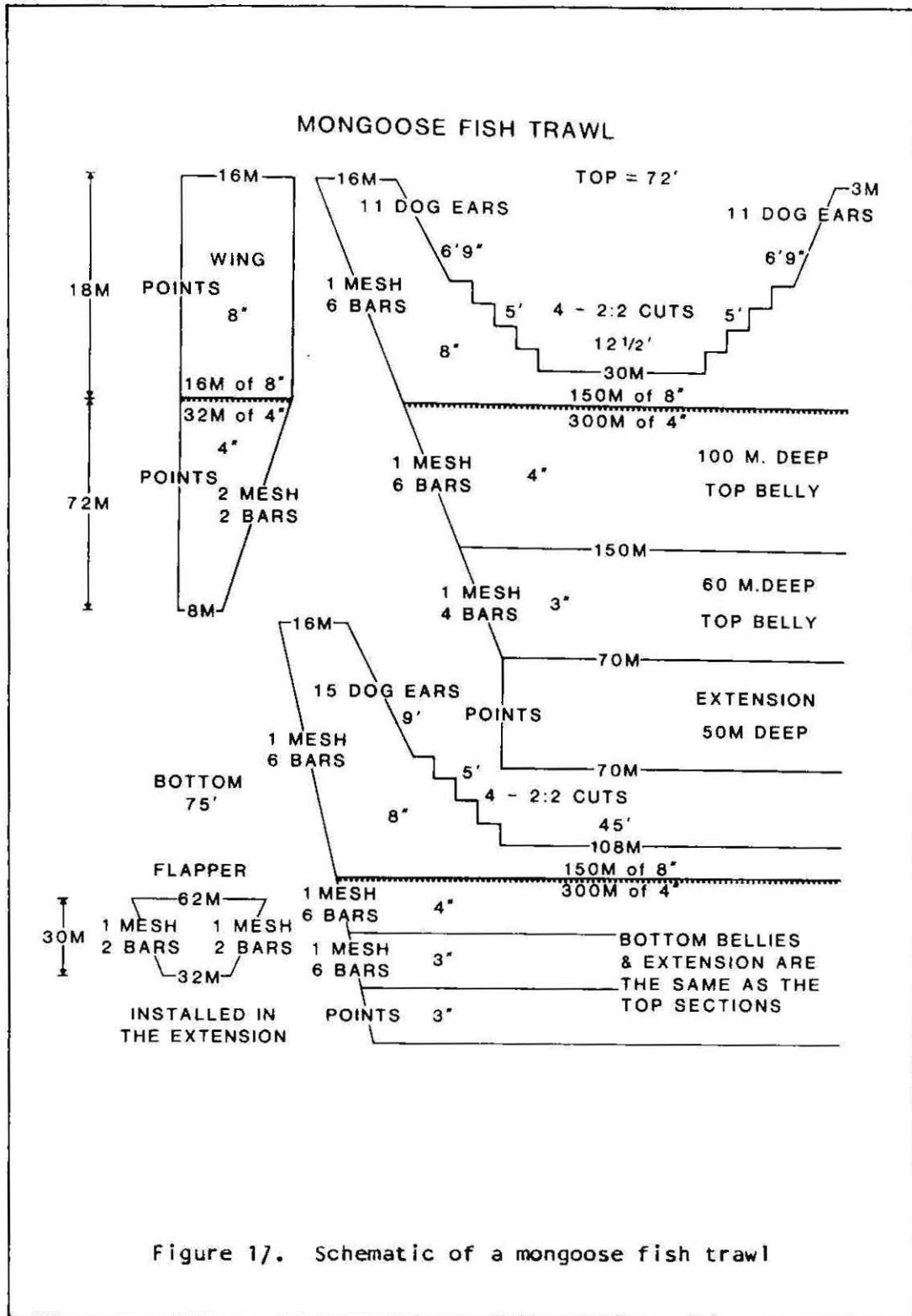

Figure 17. Schematic of a mongoose fish trawl

b. Mongoose fish trawl

Headrope: 1 length of 9/16" diameter, combination netrope, 72' long with thimble eye on each end.

Fishing line: 3 lengths of 5/8" diameter, 3-strand poly-dac rope, overall length of 79' long (16' + 45' + 16').

Ground sweep: 3 sections of 3/8" diameter "Trawlex" steel chain, two 14' sections and one 45' bosom section totaling 73'. All sections were covered with 3" diameter rubber discs (cookies) and 12" diameter rock hopper discs spaced 18" apart.

Floats: 18 each, 8" diameter deep sea plastic floats.

Bridles: (between trawl and boards) Top leg 30' of 3/8" diameter wire rope and bottom leg 30' of 1/2" diameter wire rope.

Hangings: Headrope - dog ears on 7-1/2" ties, points/meshes on 5" ties; Fishing line - dog ears on 8" ties, points/meshes on 5-1/4" ties.

Codend/Bag: 80M x 50M, 120 trd., 4" stretched mesh. Complete with 1" diameter, 3-strand nylon rope.

7. Rock hopper trawling gear: A rock hopper rig differs from the standard roller gear in that the large rollers do not roll on the ground chain; they are held stationary by a traveller chain (Figure 14). Instead of rolling over a bottom obstruction as would a roller-rigged net, rock hopper-rigged nets bounce over bottom obstructions. This type of net sweep was developed by European bottom draggers and seems to offer promise.
8. Total conversion costs: \$1,453, plus \$2,500 estimated value of one borrowed net, for a total of \$3,953.

B. Descriptions and methods of gear deployment for the M/V PO BOY

Captain Webster did not have a cut-out stern on his boat or gallows. Therefore, taking the net from the deck to the water proved difficult and dangerous, especially in a rough sea. The procedure used was similar to that in shrimping. It consisted of whipping the net up and pulling it overboard with the winch. The roller gear added considerable weight to the net. In rough seas the net swung back and forth with enough force that it knocked down one of his crew. An additional disadvantage developed because the independent tow blocks were mounted halfway out on the outrigger, which reduced the amount of net that could be pulled off the deck.

Handling the codend to dump the bag after each tow was done like a shrimping net by using a lazy line and pulling the bag over the rail. A disadvantage to this method was that if the net were ripped in the belly section or wing, it would go unnoticed until the net was decked again.

Captain Webster towed his nets with 10' x 44" wooden shrimp doors with iron brackets (Figure 18). Decking these doors proved no more difficult than standard chain-rigged doors. The best tow speed was 2.8 knots. Scope for the tow wires (ratio between length of wire and depth of water) was 4:1.

C. Trip Information, M/V PO BOY

Captain Webster made three fish trawling trips in the spring of 1983. Summary information for these trips is presented in Tables 11 through 13. Table 11 gives trip information such as number of sets per trip, total catch, average catch per tow, and general area fished. Net trip recovery with itemized trip expenses and income is presented in Table 12. Table 13 presents a summary of the packing slips for each trip. For a complete trip log of Captain Webster's three trawling trips giving Loran C set and haul locations, trawl time, and catch per tow, see Appendix D.

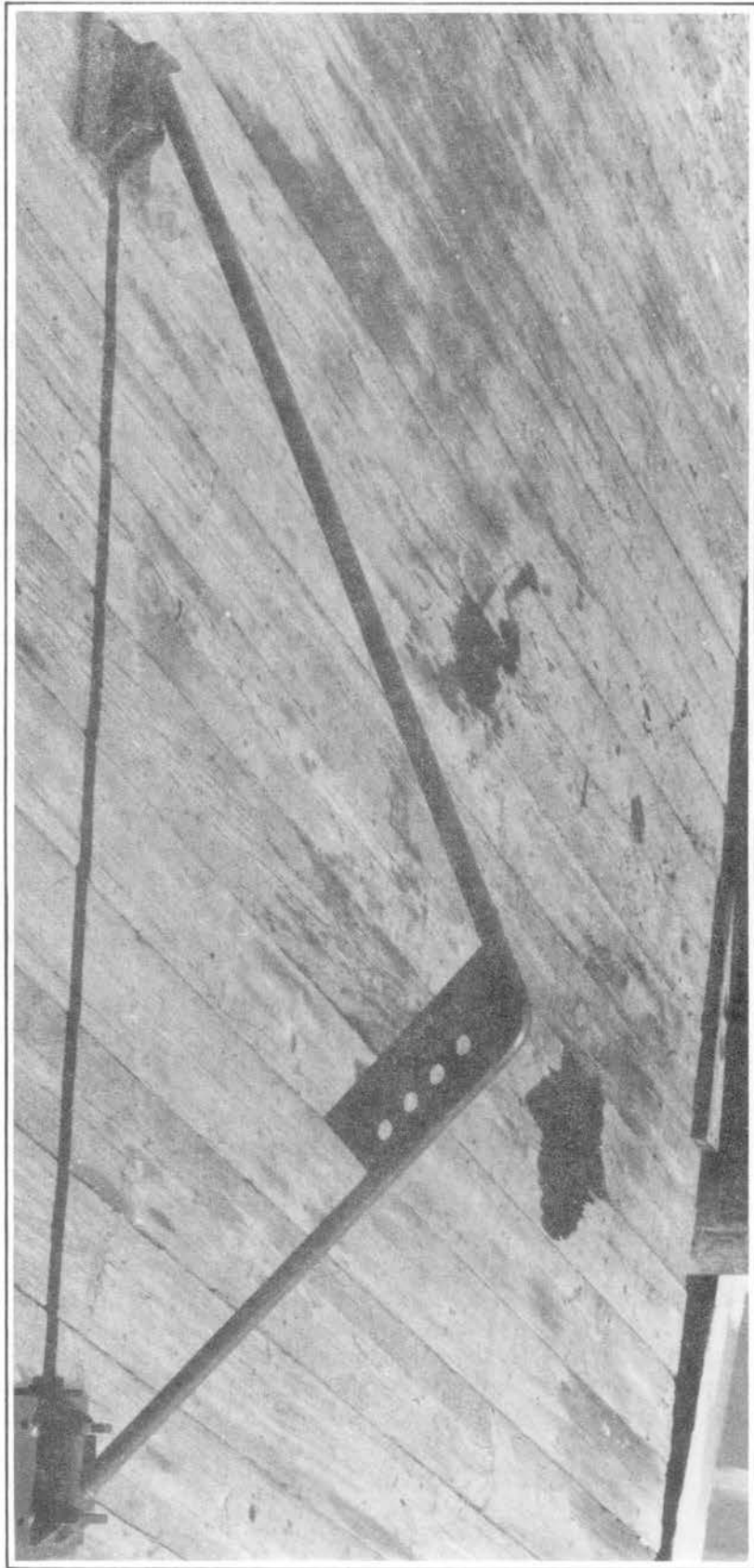

Figure 18. Bracket used on standard 10' x 44" wooden shrimp door

Table 11. Trip summary for the M/V PO BOY, 1983

<u>Trip No.</u>	<u>No. of days fished</u>	<u>Trip dates</u>	<u>No. of sets</u>	<u>Lbs.¹ of saleable fish</u>	<u>Catch per set (lbs.)</u>	<u>General area fished Loran C</u>
1	4	Mar. 29 - Apr. 2	13	802	61.7	45120.0 60875.0
2	5	Apr. 5-9	17	3,035	182.3	45150.0 45900.0
3	2	Apr. 12-15	5	745	125.4	45130.0 45860.0
Totals	11		35	4,582		

¹ Calculated from the amount of gutted fish sent to market

Table 12. Trip expenses and income generated for the M/V PO BOY (rounded to nearest dollar)

Trip No.	Itemized Trip Expenses				Total trip expenses	Gross income from fish sales	Net trip recovery
	Fuel/Oil	Ice	Groceries	Packing & freight			
1	\$1,260	\$260	\$125	\$176	\$1,822	\$1,354	(-) \$ 468
2	657	Used left-overs from 1st trip	100	668	1,425	2,943	(+) 1,518
3	630	195	95	138	1,058	723	(-) 335
Totals	\$2,547	\$455	\$320	\$982	\$4,305	\$5,020	(+) \$ 715

Table 13. Catch summary before packing and freight for the M/V PO BOY

<u>Trip No.</u>	<u>Catch (lbs.)</u>	<u>Price per pound</u>	<u>Total amount (rounded)</u>	<u>Species & grade</u>	<u>Sold to</u>
1	150	\$0.50	\$ 75	Silver snapper (mixed grade)	Behrens Seafood, New York, NY
	395	1.80	711	Gag grouper	"
	62	1.90	118	Scamp grouper	"
	96	3.00	288	Red snapper (0-8 lbs.)	"
	45	3.00	135	Red snapper (8 lbs. +)	"
	12	.40	5	Black sea bass	"
	32	.40	13	Grey triggerfish	"
	10	1.00	10	B-line snapper (1 lb. +)	"
Totals	802		\$1,355		
2	1,170	\$0.25	\$ 293	Greater amberjacks	Behrens Seafood, New York, NY
	239	1.20	287	B-liners (small)	"
	55	2.00	110	B-liners (1-2 lbs.)	"

Table 13. Catch summary before packing and freight for the
M/V PO BOY (cont'd.)

<u>Trip No.</u>	<u>Catch (lbs.)</u>	<u>Price per pound</u>	<u>Total amount (rounded)</u>	<u>Species & grade</u>	<u>Sold to</u>
2	367	\$0.90	\$ 330	Pink snapper (1-2 lbs.)	Behrens Seafood, New York, NY
	385	.30	116	Silver snapper (1-2 lbs.)	"
	522	1.75	914	Gag grouper	"
	191	3.25	621	Red snapper (1g)	"
	45	3.50	158	Red snapper (2-4 lbs.)	"
	<u>61</u>	1.90	<u>116</u>	Scamp grouper	"
Totals	3,035		\$2,945		
<hr/>					
3	78	\$1.10	\$ 86	B-liners (small)	Behrens Seafood, New York, NY
	84	2.00	168	B-liners (1-2 lbs.)	"
	227	.85	193	Pink snapper (1-2 lbs.)	"
	186	.30	56	Silver snapper	"
	118	1.65	195	Gag grouper	"
	<u>52</u>	.50	<u>26</u>	Cobia	"
Totals	745		\$ 724		

D. Problems encountered, M/V PO BOY

In addition to the handling problems mentioned above, Captain Joe Webster also had a problem with the net and door match up. Throughout his trips, he would mark good fish marks on the echosounder, but had poor catch results. He thought that the doors were overspreading the net, causing the headrope to collapse. Switching towing positions on the bracket did not seem to help as the net would not tend bottom, even though the doors were shining properly. Pulling ahead on the tongue caused the doors to nose down. Putting drop back on the tongue seemed to produce a condition where fish were getting gilled in the tongue. Catches were not increased, regardless of the changes Captain Webster tried. It is felt that not enough scope ratio was used (4:1). Possibly a 6:1 or 8:1 scope ratio would have been more efficient.

V. FISH TRAWLING - M/V CAPT. MERRITT - Capt. Jimmy Moore

A. Conversion expenses for the M/V CAPT. MERRITT

1. Outrigger supports: Four additional staywires were added to the outriggers for strength, two from the bow to the center, and two from the mast to the center of the outriggers. The staywires were constructed of 3/4" galvanized rod and 3/4" chain, tightened with 1" turnbuckles. Total cost for four additional staywires was approximately \$260.
2. Gallows: An "H"-shaped frame was installed by Captain Moore. He constructed the frame from 8" x 1/2" square stock steel pipe, so labor was not included in the cost. Captain Moore estimated the cost of the materials for the gallows and two towing blocks at \$2,650.
3. Doors, net bridles, and tow cable: Captain Moore constructed a pair of steel "V" doors 8' x 50", similar to those available on the market. His net was a Burbank 105 bottom fish trawl built by Billy Burbank, Standard Marine Hardware, Fernandina, Florida. The net was 105' on the topline and 124' on the bottomline. The sweep (Figure 19) was 124' long, constructed of 3/8" chain with 6" cookies. The net's

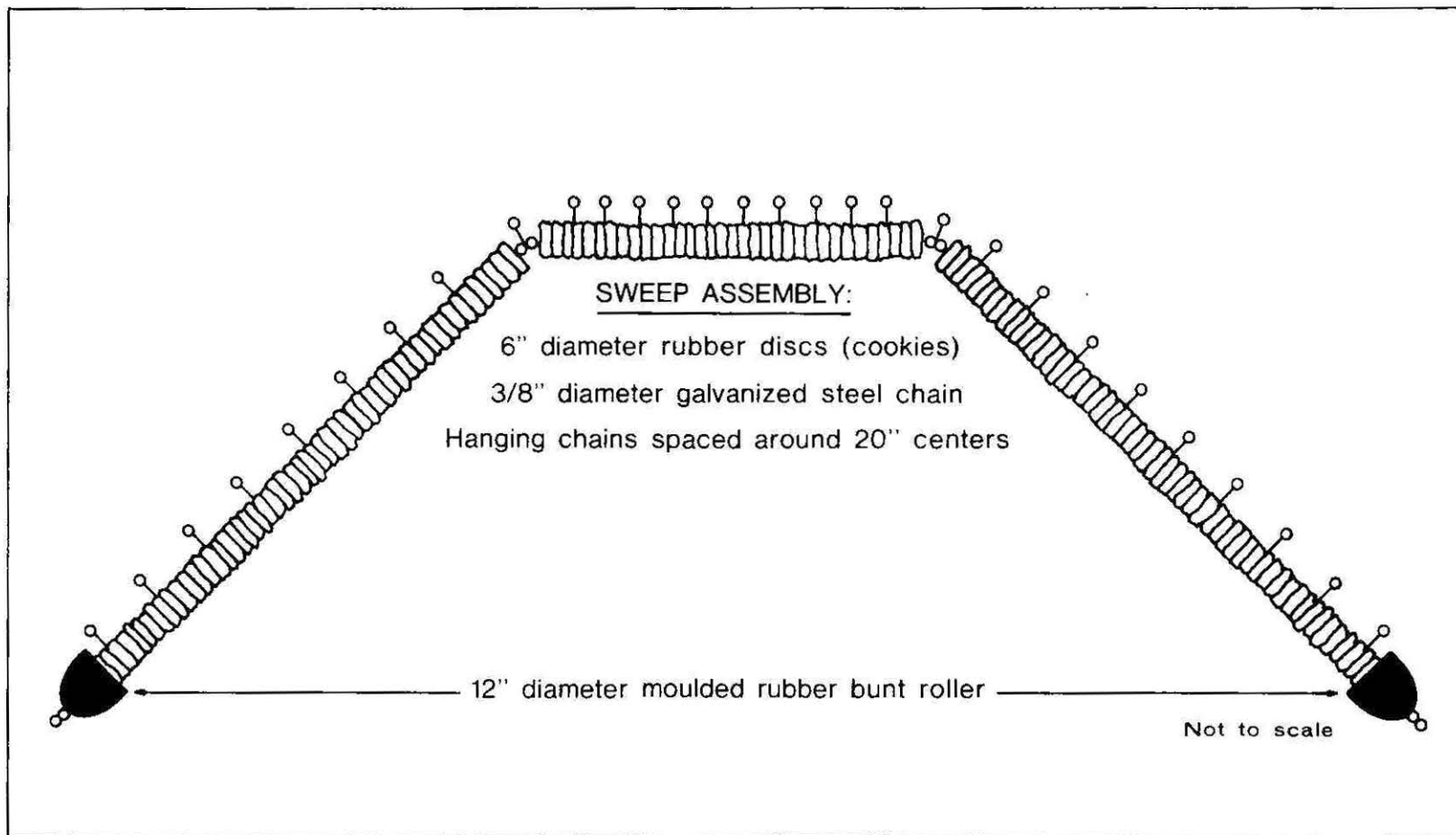

Figure 19. Cookie Sweep construction used on Billy Burbank 105' fish trawl

webbing tapered from 8" webbing to 4" to 3" with a double-stitched 2-1/2" bay section. Tow cables were 1,200 feet per side and made of 1/2" Rochester brand cable. Scissor bridles, 100 feet each, were constructed of 7/16" and 3/8" cable and were hooked from the doors to the wings of the net. The topline had 32 8" hard plastic fish floats. Total cost for the above gear was \$8,200.

4. Total Conversion Costs: \$11,110.

B. Description and methods of gear deployment for the M/V CAPT. MERRITT

1. Undecking the net: The roller gear was laid across the stern caprail similar to the way shrimpers put tickler chains on the caprail. The captain would then steam forward at about 4 knots while the crew threw the codend overboard. The water pressure helped pull the rest of the net into the water, including the roller gear. The net was now trailing behind the boat, hanging from the gallows by the scissor bridles which were attached to the main tow cable. At this time the doors were not attached to the net.
2. Setting the net: With the net in the water, the 100-foot scissor bridles were run back and the doors were hooked up to the main tow cable with the scissor bridles now attached to the doors (Figure 20). One door hung from each gallow. When the net was set out, caution had to be used to keep the length of the tow cable on each side the same. Good cable markers were a necessity. A 4:1 scope was used.
3. Dumping the bag: During haul back the doors were brought up to the gallows, chained off, and left hanging from the gallows rig. The main tow cable was then slacked off enough to unhook the doors from the main cable. Then the scissor bridles were wound up on the winch. When the wings of the net reached the gallow's block, the port wing was tied off to the gallows and the starboard wing slacked off. This allowed the net to fall off to the port side. The lazy line was attached to the net's wing with a "G" hook. It was unclipped and hooked to another "G"

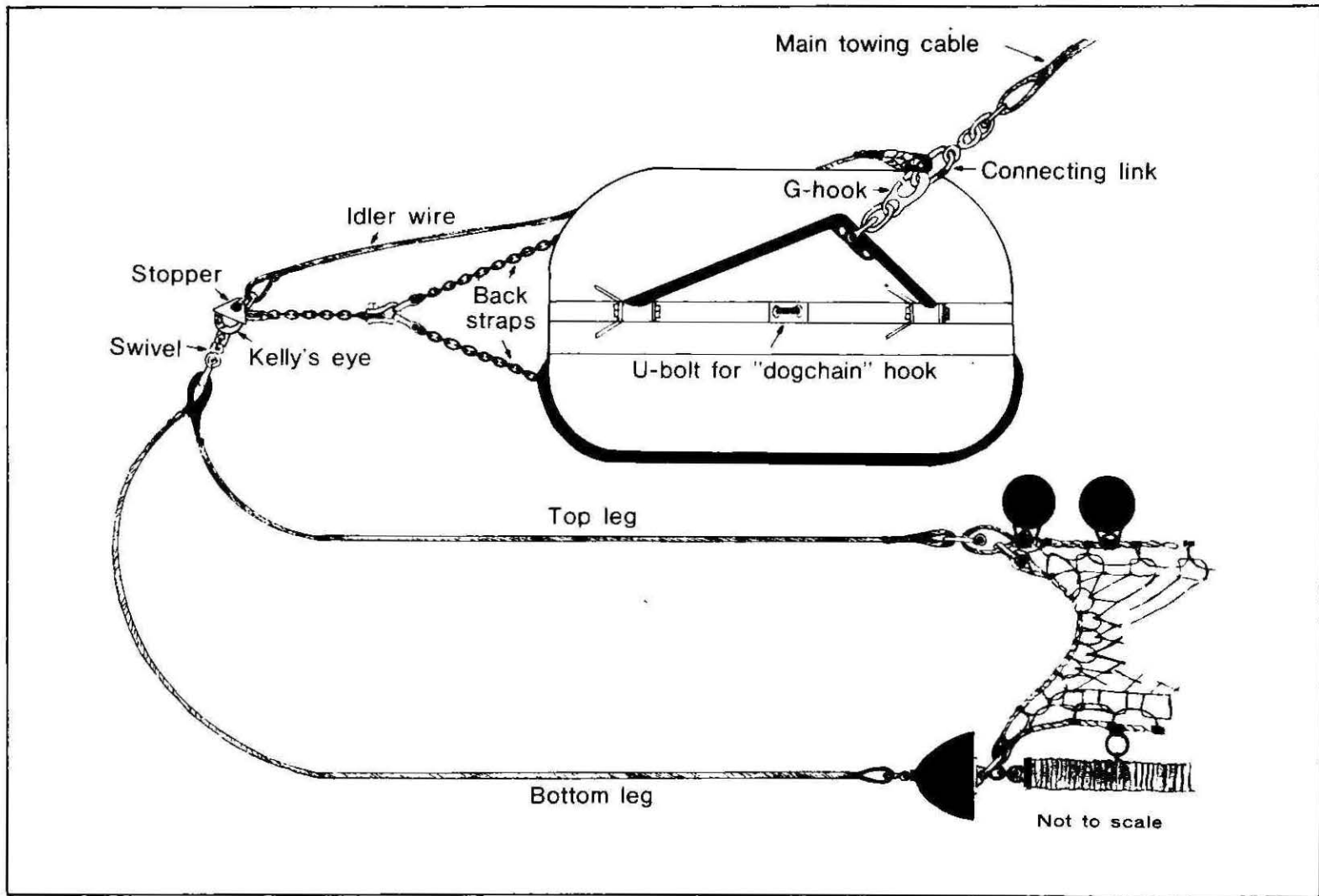

Figure 20. Schematic of door-to-net arrangement used by Captain Moore

hook attached to the trynet cable. The trynet cable ran from the winch to a block on the outrigger and back through a block on the boom, centered over the stern deck. The bag was brought onboard over the stern rail by taking up on the trynet winch and winding up the lazy line until the bag reached the top of the boom. The fish were then dumped, the bag retied, thrown overboard, and the trynet winch slacked off. The lazy line was unclipped from the trynet winch cable and reattached to the wing of the net. The net was then ready to be set again.

C. Trip Information, M/V CAPT. MERRITT

Captain Jimmy Moore made five roller-rigged fish trawling trips in the spring of 1983. Summary information for these trips is presented in Tables 14 and 15. Table 14 gives trip information such as number of sets per trip, total catch, average catch per tow, and general area fished. Table 15 presents a summary of the packing slips for several of the trips. A complete trip log for four trawling trips, giving Loran C set and haul locations, tow time, and catch per tow, is summarized in Appendix E.

D. Problems encountered, M/V CAPT. MERRITT

Captain Moore stated that his only major problems were lack of experience and poor weather.

SUMMARY

The efforts of the five captains involved in this year's project must be highly commended. The three bottom longlining boats produced a combined catch of 32,578 pounds of snowy grouper, grey tilefish, and golden tilefish with an ex-vessel value of \$38,547. This represented a total effort of only 38 actual fishing days and 155 bottom longline sets with an average of 210 pounds of fish per set. Prices for snowy grouper, grey tilefish, and golden tilefish ranged from \$1.00 to \$1.90, \$.50 to \$1.00, and \$.80 to \$2.00, respectively. Local markets usually paid more for the fish than larger establishments, but could only handle small amounts of fish at one time. Panhandling (retailing) some of the

Table 14. Trip summary for the M/V CAPT. MERRITT, 1983

<u>Trip No.</u>	<u>No. of days fished</u>	<u>Trip dates</u>	<u>No. of sets</u>	<u>Lbs.¹ of saleable fish</u>	<u>Catch per set (lbs.)</u>	<u>General area fished Loran C</u>
1	2	Mar. 28-31	5	814	163.0	45115.0 60910.0
2	4	Apr. 5-10	20	4,995	249.8	45120.0 60900.0
3	2	Apr. 12-15	8	2,311	288.9	45140.0 60830.0
4	5	Apr. 25-30	24	8,317	346.5	45120.0 & 45290.0 60900.0 & 61230.0
5	4	May 10-14	16	5,512	344.5	Not given
Totals	17		73	21,949		

¹ Calculated from the amount of gutted fish sent to market

Table 15. Catch summary before packing and freight for the M/V CAPT. MERRITT

<u>Trip No.</u>	<u>Catch (lbs.)</u>	<u>Price per pound</u>	<u>Total amount (rounded)</u>	<u>Species & grade</u>	<u>Sold to</u>
3	1,293	\$1.35	\$1,746	Gag grouper	Behrens Seafood, New York, NY
	182	1.49	271	Scamp grouper	"
	137	2.84	389	Red snapper (1g)	"
	52	1.59	83	B-liners (3/4 - 2 lbs.)	"
	37	No sale	0	Black drum	"
	14	No sale	0	Bigeye	"
	154	.60	92	Pink snapper (2 lbs. +)	"
	100	.40	40	Pink snapper (Under 2 lbs.)	"
	150	.15	23	Silver snapper (Under 2 lbs.)	"
	192	.15	29	Silver snapper (2 lbs. +)	"
Totals	2,311		\$2,673		

Table 15. Catch summary before packing and freight for the
M/V CAPT. MERRITT (cont'd.)

<u>Trip No.</u>	<u>Catch (lbs.)</u>	<u>Price per pound</u>	<u>Total amount (rounded)</u>	<u>Species & grade</u>	<u>Sold to</u>
4	93	\$1.00	\$ 93	Pink snapper	Jekyll Seafood, Jekyll Island, GA
	84	1.00	84	King mackerel	"
	99	.70	69	Cobia	Captain's Table Restaurant, Brunswick, GA
	165	.60	99	Silver snapper (lg)	"
	137	.60	82	Silver snapper (sm)	"
	32	1.50	48	B-liners (3/4 - 1 lb.)	Behrens Seafood, New York, NY
	5,794	.85	4,925	B-liners	"
	347	1.10	382	Pink snapper (lg)	"
	214	.90	193	Pink snapper (sm)	"
	399	.75	299	Black fish	"

Table 15. Catch summary before packing and freight for the
M/V CAPT. MERRITT (cont'd.)

<u>Trip No.</u>	<u>Catch (lbs.)</u>	<u>Price per pound</u>	<u>Total amount (rounded)</u>	<u>Species & grade</u>	<u>Sold to</u>
4	79	\$0.35	\$ 28	Bigeye	Behrens Seafood, New York, NY
	438	1.35	591	Gag grouper	"
	118	1.45	171	Scamp grouper	"
	210	2.25	473	Red snapper (1g)	"
	52	2.85	148	Red snapper (2-3 lbs.)	"
	42	2.65	111	Red snapper (1-1½ lbs.)	"
	<u>14</u>	1.35	<u>19</u>	Strawberry grouper	"
Totals	8,317		\$7,815		

catch and shipping the excess to New York seemed to be the most profitable way of marketing.

The three bottom longlining vessels together set 76,642 hooks, for an average catch per hook of 0.43 lbs. Catch per hook in pounds ranged from 0.15 to 1.24, with the highest rate for one trip from the M/V BLACKBEARD.

Trip expenses varied considerably between the three boats, ranging from \$149.90 to \$1,821.05, with an average expense of \$1,251.72.

The roller-rigged fish trawling boats together produced a gross stock of 26,531 pounds of fish, predominantly red snapper, scamp, gay grouper, vermillion snapper, red pogy, and whitebone pogy with an ex-vessel value of \$28,562. This represented a combined effort of 28 fishing days and 108 dragging sets with an average of 245 pounds of fish per tow.

Prices for the fish caught by dragging are highly variable. Red snapper, the most valuable component of the trawl catch, had a price range from \$2.25/lb. to \$3.50/lb., with an average price of about \$3.00/lb. Grouper averaged around \$1.75/lb., with pink porgies (pink snapper) and whitebone porgies (silver snapper) bringing an average of approximately \$.90/lb. and \$.50/lb., respectively. The largest component of trawl catches were vermillion snapper (8-liners). These fish have a price range that is dependent on size. Small fish (less than 3/4 lb.) sold for about \$1.00/lb. Medium-sized fish (3/4 to 2 lbs.) commanded about \$1.35/lb. and large vermillion snapper (greater than 2 lbs.) averaged about \$2.00/lb.

Considering the fact that the bottom longlining captains or crews had no previous bottom longlining experience, and only one of the fish dragging vessel captains (Joe Webster) had offshore dragging experience, the results were excellent for so few fishing days. Moreover, considerable time was devoted to searching for new fishing grounds, gear modifications, and improvement of fishing methods.

APPENDICES

THIS PAGE LEFT INTENTIONALLY BLANK

APPENDIX A

Trip Logs for Captain Charlie Phillips,
M/V BLACKBEARD, Bottom Longlining

Appendix A. M/V BLACKBEARD Log, Trip No. 1
Bottom Longlining

<u>Date</u>	<u>Set No.</u>	<u>No. of hooks</u>	<u>Set location</u>	<u>Haul location</u>	<u>Catch</u>	<u>Notes</u>
4-5-83	1	200	-----	-----	1 Snowy grouper	-----
	2	150	-----	-----	26 Snowy grouper	-----
	3	150	45107.8 60822.2	45108.9 60794.8	11 Grey tilefish	-----
4-6-83	1	240	45132.7 60857.5	45134.4 60840.7	1 Snowy grouper	240 ft. deep
	2	254	45109.7 60849.8	45110.5 60836.7	1 Grey tilefish	325 ft. deep
	3	647	45090.1 60756.8	45093.3 60725.0	83 Golden tilefish	656 ft. deep

Appendix A. M/V BLACKBEARD Log, Trip No. 2
Bottom Longlining

<u>Date</u>	<u>Set No.</u>	<u>No. of hooks</u>	<u>Set location</u>	<u>Haul location</u>	<u>Catch</u>	<u>Notes</u>
4-14-83	1	714	45089.6 60759.3	45093.1 60718.0	54 Golden tilefish	-----
	2	946	45087.4 60765.3	45096.1 60724.2	84 Golden tilefish 1 Snowy grouper	-----
4-15-83	Ran almost all the way home, then weather changed, ran back to grounds (14 hrs. running)					
4-16-83	1	700	45110.1 60845.5	-----	24 Snowy grouper	-----
	2	743	45107.9 60842.1	45110.9 60814.8	25 Snowy grouper 14 Grey tilefish	370 ft. deep
	3	625	45088.3 60772.3	-----	41 Golden tilefish 48 Snowy grouper	Good spot
4-17-83	1	625	45088.9 60772.4	-----	65 Snowy grouper 24 Golden tilefish	Good spot
	2	550	45088.3 60772.0	-----	14 Snowy grouper 21 Golden tilefish	Good spot
	3	525	45088.4 60770.8	-----	18 Snowy grouper 15 Golden tilefish	Good spot
4-18-83	1	525	45088.0 60770.0	-----	1 Golden tilefish	-----
	2	525	45088.0 60770.0	-----	1 Snowy grouper	-----

Appendix A. M/V BLACKBEARD Log, Trip No. 3
Bottom Longlining

<u>Date</u>	<u>Set No.</u>	<u>No. of hooks</u>	<u>Set location</u>	<u>Haul location</u>	<u>Catch</u>	<u>Notes</u>
4-21-83	1	450	45089.0 60768.6	-----	7 Golden tilefish	-----
	2	600	45087.5 60783.5	45088.3 60760.1	21 Golden tilefish	-----
	3	603	45088.1 60773.4	45089.0 60775.0	24 Golden tilefish 4 Snowy grouper	-----
	4	475	45088.8 60772.6	45089.2 60756.8	36 Golden tilefish 23 Snowy grouper	-----
	5	350	45089.7 60771.2	45089.3 60761.5	3 Golden tilefish 14 Snowy grouper	-----
4-22-83	1	340	45090.0 60770.8	45089.3 60770.8	2 Golden tilefish 29 Snowy grouper	-----
	2	350	45090.5 60770.6	45089.8 60760.8	8 Golden tilefish	-----
	3	355	45089.7 60768.5	45090.1 60757.3	4 Golden tilefish 21 Snowy grouper	-----
	4	300	45088.8 60769.6	45090.3 60758.7	1 Golden tilefish 34 Snowy grouper	-----
	5	300	45087.8 60769.7	45089.8 60761.1	3 Golden tilefish 58 Snowy grouper	-----
	6	344	45088.0 60770.2	45089.6 60760.7	3 Golden tilefish 1 Snowy grouper	-----
	7	325	45088.7 60769.7	45089.6 60758.9	2 Snowy grouper	-----

Appendix A. M/V BLACKBEARD Log, Trip No. 4
Bottom Longlining

<u>Date</u>	<u>Set No.</u>	<u>No. of hooks</u>	<u>Set location</u>	<u>Haul location</u>	<u>Catch</u>	<u>Notes</u>
4-26-83	1	400	45337.1 61199.5	45337.9 61191.5	32 Black sea bass	Small fish
4-27-83	1	340	45087.8 60771.1	45089.6 60761.2	2 Snowy grouper	-----
	2	325	45087.6 60770.8	45084.5 60761.7	1 Grey tilefish 2 Golden tilefish	-----
	3	375	45088.0 60771.7	45089.9 60761.4	4 Golden tilefish 7 Snowy grouper	-----
	4	337	45088.7 60771.3	-----	23 Snowy grouper	-----
	5	365	45088.7 60770.1	45090.1 60760.8	1 Golden tilefish 8 Snowy grouper	-----
	6	350	45089.0 60771.4	45089.1 60761.4	6 Golden tilefish	-----
	7	302	45070.5 60750.1	45073.2 60744.6	No commercial catch	-----

Appendix A. M/V BLACKBEARD Log, Trip No. 4
 Bottom Longlining (cont'd.)

<u>Date</u>	<u>Set No.</u>	<u>No. of hooks</u>	<u>Set location</u>	<u>Haul location</u>	<u>Catch</u>	<u>Notes</u>
4-28-83	1	400	45087.7 60770.4	45090.0 60761.2	2 Golden tilefish 23 Snowy grouper	-----
	2	350	45087.6 60770.6	45090.0 60760.9	47 Snowy grouper	-----
	3	370	45087.5 60769.3	45089.9 60751.4	1 Golden tilefish	-----
	4	390	45087.1 60770.4	45089.6 60761.5	2 Golden tilefish 33 Snowy grouper	-----
	5	425	45087.9 60770.6	45089.8 60761.5	2 Golden tilefish 7 Snowy grouper	-----
	6	303	45087.3 60768.5	45089.6 60761.1	2 Golden tilefish 7 Snowy grouper	-----
	7	200	45088.0 60766.4	45089.5 60761.8	4 Snowy grouper	-----
4-29-83	1	528	45087.7 60771.1	45089.3 60763.0	4 Golden tilefish 23 Snowy grouper	-----
	2	275	45088.1 60765.9	45088.7 60765.9	1 Golden tilefish 1 Snowy grouper	-----
	3	300	45088.8 60766.6	45089.7 60761.2	3 Snowy grouper	-----
	4	275	45089.3 60767.1	45089.6 60760.9	11 Snowy grouper	-----

Appendix A. M/V BLACKBEARD Log, Trip No. 4
Bottom Longlining (cont'd.)

<u>Date</u>	<u>Set No.</u>	<u>No. of hooks</u>	<u>Set location</u>	<u>Haul location</u>	<u>Catch</u>	<u>Notes</u>
4-29-83	5	143	45088.8 60763.1	45089.8 60762.3	No commercial catch	-----
	6	600	45108.0 60792.7	45108.0 60792.7	No commercial catch	-----
4-30-83	1	225	45087.4 60766.8	45090.0 60761.0	No commercial catch	-----
	2	400	45086.6 60769.6	45090.0 60761.5	2 Golden tilefish	-----
	3	600	45081.9 60748.1	-----	31 Golden tilefish	780 ft. deep
	4	740	-----	45082.5 60740.2	56 Golden tilefish	-----
	5	137	45085.2 60731.3	45085.4 60725.6	15 Golden tilefish	-----
5-1-83	1	400	45086.9 60768.0	45089.7 60762.1	9 Snowy grouper 4 Golden tilefish	-----
	2	450	45087.1 60768.4	45090.2 60761.1	2 Snowy grouper 1 Golden tilefish	-----
	3	787	45080.6 60748.7	45084.1 60730.7	23 Golden tilefish	-----

Appendix A. M/V BLACKBEARD Log, Trip No. 5
Bottom Longlining

<u>Date</u>	<u>Set No.</u>	<u>No. of hooks</u>	<u>Set location</u>	<u>Haul location</u>	<u>Catch</u>	<u>Notes</u>
6-20-83	1	330	45087.6	45090.2	6 Golden tilefish	-----
			60770.5	60760.8	5 Snowy grouper	
	2	300	45087.8	45090.2	3 Golden tilefish	-----
			60768.6	60761.1	16 Snowy grouper	
	3	300	45086.5	45086.5	7 Golden tilefish	-----
60766.5			60776.6	9 Snowy grouper		
4	400	45087.9	45090.0	3 Golden tilefish	-----	
		60768.4	60761.5	9 Snowy grouper		
5	375	45086.4	45089.6	5 Golden tilefish	-----	
		60766.2	60761.5	2 Snowy grouper		
6-21-83	1	300	45087.8	45089.6	3 Golden tilefish	-----
			60767.6	60760.5		
	2	300	45089.3	45089.8	1 Golden tilefish	-----
			60767.1	60761.4	10 Snowy grouper	
	3	330	45088.5	45090.1	1 Snowy grouper	-----
60766.3			60760.9			
4	650	45089.3	45091.7	30 Golden tilefish	-----	
		60756.2	60738.8			
5	675	45087.1	45090.0	24 Golden tilefish	-----	
		60749.5	60733.5			
6-22-83	1	333	45088.1	45090.1	6 Golden tilefish	-----
			60767.3	60759.5		
2	350	45060.3	45062.7	No commercial catch	-----	
		60848.7	60841.0			

APPENDIX B

Trip Logs for Captain Roy Purvis,
M/V CREDIT, Bottom Longlining

Appendix B. M/V CREDIT Log, Trip No. 1
Bottom Longlining

<u>Date</u>	<u>Set No.</u>	<u>No. of hooks</u>	<u>Set location</u>	<u>Haul location</u>	<u>Catch</u>	<u>Notes</u>
3-15-83	1	250	45109.0 60828.0	45110.5 60808.7	Total for 3 sets:	Squid for bait
	2	509	45110.8 60834.0	45110.8 60809.6	431 lbs. Snowy grouper	Squid for bait
	3	550	45109.2 60838.0	45111.3 60820.2	237 lbs. Grey tilefish	Squid for bait
					82 total fish	

Appendix B. M/V CREDIT Log, Trip No. 2
Bottom Longlining

<u>Date</u>	<u>Set No.</u>	<u>No. of hooks</u>	<u>Set location</u>	<u>Set times (EST)</u>	<u>Haul location</u>	<u>Haul times (EST)</u>	<u>Catch</u>	<u>Notes</u>
3-28-83	1	630	45109.2 60830.0	0845- 0935	45109.3 60810.7	0950- 1100	2 Snowy grouper 34 Grey tilefish	342 ft. deep
	2	489	45109.2 60827.6	1105- 1150	45109.6 60810.1	1210- 1150	7 Snowy grouper 19 Grey tilefish	Squid and shark bait 318 ft. deep
	3	750	45109.7 60827.6	1330- 1430	45111.3 60806.6	1515- 1630	10 Snowy grouper 21 Grey tilefish	-----
	4	350	45109.0 60826.0	1635- 1700	45108.8 60814.7	1730- 1845	6 Grey tilefish	-----
3-29-83	1	700	45109.2 60830.2	0800- 0900	45110.0 60816.0	0920- 1030	39 Snowy grouper 18 Grey tilefish	-----
	2	550	45109.2 60830.2	1030- 1110	45109.0 60820.0	1140- 1230	11 Snowy grouper 32 Grey tilefish	-----
	3	770	45109.2 60830.2	1240- 1330	45109.7 60816.3	1425- 1500	5 Snowy grouper 5 Grey tilefish	-----
	4	255	45114.0 60829.9	1500- ?	----- -----	? 1630	No commercial catch	288 ft. deep
	5	617	45109.2 60829.0	1645- 1700	45109.4 60816.2	1730- 1830	27 Snowy grouper 7 Grey tilefish	-----

Appendix B. M/V CREDIT Log, Trip No. 2
Bottom Longlining (cont'd.)

<u>Date</u>	<u>Set No.</u>	<u>No. of hooks</u>	<u>Set location</u>	<u>Set times (EST)</u>	<u>Haul location</u>	<u>Haul times (EST)</u>	<u>Catch</u>	<u>Notes</u>
3-29-83	6	250	45109.2 60829.0	1830- 1845	45109.4 60816.2	1900- 1930	2 Snowy grouper 1 Grey tilefish	-----
3-30-83	1	700	45109.2 60830.4	0700- 0730	45109.4 60815.0	0800- 0900	27 Snowy grouper 16 Grey tilefish 1 Shark	-----
	2	700	45081.4 60744.1	1030- 1100	45081.4 60732.7	---- ----	8 Golden tilefish	720 ft. deep
	3	500	45093.2 60729.0	---- ----	45093.0 60742.0	---- ----	32 Golden tilefish	-----
	4	650	45094.2 60718.0	---- ----	45093.6 60735.0	---- ----	19 Golden tilefish 3 Hammerhead sharks	-----

Appendix B. M/V CREDIT Log, Trip No. 3
Bottom Longlining

<u>Date</u>	<u>Set No.</u>	<u>No. of hooks</u>	<u>Set location</u>	<u>Haul location</u>	<u>Catch</u>	<u>Notes</u>
4-5-83	1	600	45109.0	45109.4	6 Grey tilefish	-----
			60830.0	60800.1	2 Snowy grouper	
	2	600	45109.0	45110.1	25 Grey tilefish	-----
			60830.0	60815.0	60 Snowy grouper	
	3	630	45109.0	45110.1	11 Grey tilefish	-----
			60830.0	60815.0	18 Snowy grouper	
4-6-83	1	575	45109.0	45110.1	12 Grey tilefish	Poor weather
			60830.0	60815.0	49 Snowy grouper	
4-7-83	1	500	45109.0	45110.1	4 Grey tilefish	-----
			60830.0	60815.0	19 Snowy grouper	
	2	750	45109.2	45109.6	14 Grey tilefish	-----
			60803.0	60820.0	23 Snowy grouper	
	3	600	45109.2	45109.6	14 Grey tilefish	-----
			60803.0	60820.0	7 Snowy grouper	
4-8-83	1	600	45083.5	45084.5	39 Golden tilefish	-----
			60845.0	60731.1		
	2	720	45081.5	45084.5	31 Golden tilefish	-----
			60846.5	60731.1		
	3	900	45097.2	45097.8	18 Golden tilefish	-----
			60760.0	60733.4		
	4	850	45086.0	45086.7	47 Golden tilefish	-----
			60745.2	60732.5		
	5	900	45087.1	45088.6	65 Golden tilefish	-----
			60747.6	60731.0		
	6	600	45086.6	45088.5	19 Golden tilefish	-----
			60745.0	60727.3		

Appendix B. M/V CREDIT Log, Trip No. 4
Bottom Longlining

<u>Date</u>	<u>Set No.</u>	<u>No. of hooks</u>	<u>Set location</u>	<u>Haul location</u>	<u>Catch</u>	<u>Notes</u>
4-13-83	1	600	45090.8 60733.4	45089.3 60741.1	13 Golden tilefish	-----
	2	900	45091.0 60753.0	45095.0 60740.0	55 Golden tilefish	-----
	3	900	45091.0 60755.0	45094.2 60739.6	56 Golden tilefish	-----
	4	900	45090.0 60753.0	45096.4 60741.3	48 Golden tilefish	-----
4-14-83	1	700	45109.0 60817.1	45109.2 60831.0	30 Grey tilefish 24 Snowy grouper	-----
	2	700	45109.0 60817.1	45109.2 60831.0	11 Grey tilefish 8 Snowy grouper	-----
	3	700	45109.0 60817.1	45109.2 60831.0	4 Grey tilefish 11 Snowy grouper	-----
4-15-83	1	900	45090.6 60732.6	45088.0 60747.0	49 Golden tilefish	Weather began to get bad, left for home

Appendix B. M/V CREDIT Log, Trip No. 5
Bottom Longlining

<u>Date</u>	<u>Set No.</u>	<u>No. of hooks</u>	<u>Set location</u>	<u>Haul location</u>	<u>Catch</u>	<u>Notes</u>
4-18-83	1	850	45109.0 60835.0	45109.6 60820.0	12 Grey tilefish 18 Snowy grouper	-----
	2	945	45088.0 60760.0	45090.5 60742.0	30 Golden tilefish	-----
	3	600	45083.0 60750.0	45082.0 60730.0	19 Golden tilefish	Buck shad for bait with some squid
	4	600	45088.7 60755.0	45089.0 60740.0	12 Golden tilefish	Buck shad for bait with some squid
4-19-83	1	700	45093.0 60760.0	45091.8 60739.7	25 Golden tilefish	-----
	2	850	45094.4 60760.0	45094.0 60740.0	23 Golden tilefish	-----
	3	650	45109.4 60730.4	45109.6 60816.0	6 Grey tilefish 8 Snowy grouper	Poor weather
4-20-83	1	800	45090.0 60760.0	45090.0 60742.0	18 Golden tilefish	-----
	2	550	45088.0 60768.0	45088.0 60761.0	3 Golden tilefish	-----
	3	700	45101.6 60554.2	45102.8 60541.6	23 Golden tilefish	-----
	4	700	45098.3 60554.2	45097.9 60536.3	30 Golden tilefish	-----

Appendix B. M/V CREDIT Log, Trip No. 6
Bottom Longlining

<u>Date</u>	<u>Set No.</u>	<u>No. of hooks</u>	<u>Set location</u>	<u>Haul location</u>	<u>Catch</u>	<u>Notes</u>
4-27-83	1	400	45103.0 60851.0	45106.5 60840.0	7 Grey tilefish	-----
	2	185	45118.5 60930.0	45118.2 60923.5	5 Snowy grouper 2 Red snapper	-----
	3	328	45118.5 60930.0	45118.3 60923.5	2 Snowy grouper	-----
	4	410	45118.2 60933.0	45118.3 60924.4	Nothing caught	-----
	5	286	45127.0 60877.0	45127.0 60869.0	2 Snowy grouper	-----
	6	250	45125.7 60880.0	45126.0 60875.0	1 Grey tilefish 3 Snowy grouper	-----
4-28-83	1	300	45126.0 60877.0	45126.0 60870.0	7 Snowy grouper	-----
	2	300	45126.0 60877.0	45126.0 60870.0	3 Snowy grouper	-----
	3	300	45126.0 60877.0	45126.0 60870.0	1 Grey tilefish 4 Snowy grouper	-----
	4	300	45126.0 60877.0	45126.0 60870.0	4 Snowy grouper	-----
	5	400	45126.0 60877.0	45126.0 60870.0	1 Grey tilefish 6 Snowy grouper	-----
	6	300	45133.0 60895.5	45133.0 60890.4	5 Snowy grouper	-----

Appendix B. M/V CREDIT Log, Trip No. 6
Bottom Longlining (cont'd.)

<u>Date</u>	<u>Set No.</u>	<u>No. of hooks</u>	<u>Set location</u>	<u>Haul location</u>	<u>Catch</u>	<u>Notes</u>
4-28-83	7	300	45133.0	45133.0	2 Grey tilefish	-----
			60895.5	60890.4	3 Snowy grouper	
4-29-83	1	250	45126.0	45126.0	4 Snowy grouper	-----
			60880.0	60876.0		
	2	600	45109.1	45109.6	11 Grey tilefish	-----
			60832.0	60820.0	32 Snowy grouper	
	3	631	45109.1	45109.6	5 Grey tilefish	-----
			60832.0	60820.0	14 Snowy grouper	
4-30-83	4	550	45109.1	45109.6	2 Grey tilefish	-----
			60832.0	60820.0	6 Snowy grouper	
	5	607	45109.1	45109.6	8 Snowy grouper	-----
			60832.0	60820.0		
	6	515	45109.1	45109.6	3 Snowy grouper	-----
			60832.0	60820.0		
4-30-83	1	750	45092.0	45096.0	18 Golden tilefish	-----
			60755.1	60742.0		
	2	900	45088.9	45091.9	28 Golden tilefish	-----
			60749.0	60732.4		
	3	650	45094.0	45096.2	28 Golden tilefish	-----
		60730.0	60715.3			
4-30-83	4	700	45094.0	45096.2	21 Golden tilefish	-----
			60730.0	60715.3		
	5	1,080	45091.0	45093.6	22 Golden tilefish	-----
			60740.0	60718.0		

Appendix B. M/V CREDIT Log, Trip No. 6
 Bottom Longlining (cont'd.)

-08-

<u>Date</u>	<u>Set No.</u>	<u>No. of hooks</u>	<u>Set location</u>	<u>Haul location</u>	<u>Catch</u>	<u>Notes</u>
4-30-83	6	650	45109.0 60832.0	45109.6 60820.0	3 Snowy grouper	-----

APPENDIX C

Trip Logs for Captain Raleigh Purvis,
M/V WAR HORSE, Bottom Longlining

Appendix C. M/V WAR HORSE Log, Trip No. 1
Bottom Longlining

<u>Date</u>	<u>Set No.</u>	<u>No. of hooks</u>	<u>Set & haul location</u>	<u>Catch</u>
4-20-83	1	200	Between 45088.0 and 45095.0 (No Loran 60 info. given)	Total for 3 sets: 200 lbs. Grey tilefish 400 lbs. Golden tilefish
	2	300		
	3	600		

Appendix C. M/V WAR HORSE Log, Trip No. 2
Bottom Longlining

Dates fished: April 27-29, 1983, approximately 25 hours total fishing time.

No. of sets: A total of ten sets were made, four each on the first two days, and only two sets on April 29.

No. of hooks: Approximately 300 hooks were used on each set.

Bait: Squid, shark, and buck shad were used as bait. Squid and shark worked best; the shad was too soft and fell off the hooks.

Location fished: Grey tilefish were caught on 45090.0 and 45095.4
60760.0 60767.0

Snowy grouper were caught on 45118.0 A large ledge
60867.4

45109.0 and 45137.0
60835.0 60812.0

Catch: 1,200 lbs. of Snowy grouper
110 lbs. of Grey tilefish

Note No. 1: On location 45118.0
60867.4, 42 Snowy grouper were caught on 300 hooks soaking for
approximately two hours, April 28, 1983.

Note No. 2: Good fish were marked at 45284.5
61155.2. This area was not fished.

THIS PAGE LEFT INTENTIONALLY BLANK

APPENDIX D

Trip Logs for Captain Joe Webster,
M/V PO BOY, Rock Hopper-Rigged
Fish Trawling

Appendix D. M/V PO BOY Log, Trip No. 1
Rock Hopper-Rigged Fish Trawling

Date	Tow No.	Time of tow (E.S.T.)	Set location	Haul location	Catch	Notes
3-30-83	1	0620-0800	45117.0 60906.0	45117.0 60900.0	Nothing caught	No bottom
	2	0840-1018	45119.0 60904.0	45117.0 60904.0	3 Red snapper 7 Grouper	Net still not right
	3	1100-1230	45109.5 60903.0	45115.0 60908.0	3 Red snapper 2 Grouper	-----
	4	1340-1430	45132.0 60908.0	----- -----	8 Grouper	Not fishing right
3-31-83	1	0735-0940	45142.0 60832.0	----- -----	2 Baskets pink snapper 2 Grouper	Good fish marks, marked fish for 40 minutes solid
	2	1015-1317	45140.3 60833.5	45148.1 60803.1	½ Basket mixed fish	-----
	3	1348-1600	45147.7 60794.7	45141.1 60844.7	Nothing caught	Net not fishing right
	4	1630- ?	45139.0 60845.9	----- -----	Nothing caught	Hung up, got off with no net damage but bent door bracket
4-1-83	1	1924-2110	45130.0 60893.9	45120.5 60919.9	½ Basket mixed fish 3 Red snapper 3 Grouper	-----

Appendix D. M/V PO BOY Log, Trip No. 1
 Rock Hopper-Rigged Fish Trawling
 (cont'd.)

<u>Date</u>	<u>Tow No.</u>	<u>Time of tow (E.S.T.)</u>	<u>Set location</u>	<u>Haul location</u>	<u>Catch</u>	<u>Notes</u>
4-1-83	2	1010-1200	45120.5 60910.4	----- -----	Nothing caught	Lost the bag
	3	1341-1500	45128.3 60904.6	45130.0 60889.0	1 Basket mixed fish 3 Red snapper 2 Grouper	-----
	4	1600-1800	45118.0 60903.5	45128.0 60938.1	4 Grouper	-----
4-2-83	1	0700- ?	45116.8 60918.9	----- -----	7 Red snapper 5 Grouper 5 Bulldozers 40 Lbs. mixed fish	Changed over to new net

Notes: Good fish marks

- | | | |
|-----------------------|---|-----------------------|
| 1. 45132.5
60895.4 | | 4. 45139.8
60844.8 |
| 2. 45274.2
61052.6 | Good fish marks,
saw them running in | 5. 45229.6
61058.0 |
| 3. 45139.0
60845.9 | Hang | |

Appendix D. M/V PO BOY Log, Trip No. 2
Rock Hopper-Rigged Fish Trawling

<u>Date</u>	<u>Tow No.</u>	<u>Time of tow (E.S.T.)</u>	<u>Set location</u>	<u>Haul location</u>	<u>Catch</u>	<u>Notes</u>
4-5-83	1	1330-1400	45343.1 61186.3	45344.1 61198.4	1 Basket mixed fish	Hung up and tore net Hang: 45344.1 61198.4
	2	1700- ?	45308.5 61156.7	----- -----	Nothing caught	Poor tow, no fish
4-6-83	1	0730-1015	45126.7 60894.4	45133.0 60892.0	1/2 Basket B-liners 1/2 Basket mixed fish 3 Grouper	Back to 4-seam net
	2	1033-1300	45133.4 60891.3	45145.8 60821.8	3 Red snapper 4 Grouper 1 Basket mixed fish 1/2 Basket B-liners	-----
	3	1340-1640	45146.7 60824.0	45133.1 60854.4	1-3/4 Basket mixed fish 3 Red snapper 7 Grouper	-----
	4	1700-1910	45136.2 60846.4	----- -----	2 Baskets mixed fish 4 Grouper	-----
4-7-83	1	0608-0820	45117.2 60902.5	45108.4 60903.0	1 Grouper 1/2 Basket mixed fish	Poor catch
	2	0838-1100	45112.1 60970.1	45115.0 60915.5	1/2 Basket mixed fish 1 Grouper 5 Baskets jack	-----

Appendix D. M/V PO BOY Log, Trip No. 2
 Rock Hopper-Rigged Fish Trawling
 (cont'd.)

Date	Tow No.	Time of tow (E.S.T.)	Set location	Haul location	Catch	Notes
4-7-83	3	1115-1330	45115.8 60916.7	45115.1 60933.3	1/2 Basket mixed fish 5 Grouper 1 Red snapper	4-seam net not fishing well
	4	1410-1625	45127.7 60912.7	45128.7 60928.0	Nothing caught	-----
	5	1700-1915	45127.1 60930.6	45122.9 60944.9	Nothing caught	-----
4-8-83	1	630-840	45130.6 60889.4	45136.0 60843.2	7 Grouper 42 Red snapper (sm) 1 Red snapper (lg) 1 Basket mixed fish	Back to S-X-III net, good fish marks
	2	900-1120	45137.1 60839.3	45137.0 60847.8	2 Grouper 4 Red snapper (sm) 1/2 Basket mixed fish	-----
	3	1150-1415	45136.5 60850.3	45136.1 60898.3	2 Red snapper (lg) 3/4 Basket mixed fish	-----
	4	1435-1525	45133.0 60896.2	45131.5 60862.9	1 Red snapper	-----
	5	1607-1830	45132.4 60835.0	45138.9 60835.0	1 Basket B-liners	-----
4-9-83	1	644-1000	45136.6 60836.6	45130.2 60896.6	1 Basket mixed fish 1 Grouper	Bad weather

Appendix D. M/V PO BOY Log, Trip No. 3
 Rock Hopper-Rigged Fish Trawling

-06-

<u>Date</u>	<u>Tow No.</u>	<u>Time of tow (E.S.T.)</u>	<u>Set location</u>	<u>Haul location</u>	<u>Catch</u>	<u>Notes</u>
4-13-83	1	1419-1650	45135.7 60897.3	45138.5 60896.4	1/2 Basket mixed fish	Changed from 30' to 60' leg lines
	2	1711-1930	45135.1 60895.3	45144.3 60853.2	2 Red snapper (sm) 1 Basket mixed fish	-----
4-14-83	1	0730-0940	45141.2 60830.4	45133.2 60843.7	1-3/4 Basket mixed fish 1 Red snapper (lg) 5 Grouper	Bad weather
	2	1030-1440	45133.9 60843.7	45133.1 60873.4	1-1/2 Basket mixed fish 1 Grouper	-----
	3	1510-1820	45134.5 60877.9	45122.9 60904.9	3 Baskets mixed fish 1 Red snapper (lg) 6 Red snapper (sm)	Poor weather, going home

APPENDIX E

Trip Logs for Captain Jimmy Moore,
M/V CAPT. MERRITT, Roller-Rigged
Fish Trawling

Appendix E. M/V CAPT. MERRITT Log, Trip No. 1
 Roller-Rigged Fish Trawling

<u>Date</u>	<u>Tow No.</u>	<u>Time of tow (E.S.T.)</u>	<u>Set location</u>	<u>Haul location</u>	<u>Catch</u>	<u>Notes</u>
3-29-83	1	1030-1115	45113.9 60917.7	45116.7 60902.7	2 Red snapper (1g) 1 Grouper 1 Basket mixed fish	Hung up at 45116.7 60902.7 Net torn
	2	1915-2045	45124.3 60918.2	45114.7 60924.4	2 Baskets mixed fish	-----
3-30-83	1	0700-0835	45116.6 60907.0	45118.7 60908.9	No fish caught	Bag fouled, did not dump
	2	0920-1000	45120.5 60908.7	45117.9 60924.4	4 Red snapper 9 Grouper 3 Baskets mixed fish	-----
	3	1035-1230	45121.6 60914.3	45118.4 60915.3	No fish caught	Belly torn out of net

Appendix E. M/V CAPT. MERRITT Log, Trip No. 2
Roller-Rigged Fish Trawling

<u>Date</u>	<u>Tow No.</u>	<u>Time of tow (E.S.T.)</u>	<u>Set location</u>	<u>Haul location</u>	<u>Catch</u>	<u>Notes</u>
4-6-83	1	0635-0830	45117.3 60906.6	45120.0 60904.6	1 Red snapper (1g) 2 Grouper 1 30" Spiny lobster 3 Baskets mixed fish	No good fish marks throughout tow
	2	0850-1050	45122.4 60900.4	45115.5 60911.0	Nothing but cigar minnows	No good fish marks throughout tow
	3	1115-1330	45116.7 60912.7	45118.2 60918.4	1 Red snapper (1g) 2 Gag groupers 3 Baskets mixed fish	Marked good fish at start of set
	4	1350-1620	45118.7 60922.1	45111.5 60911.0	5 Red snapper (1g) 11 Grouper 5 Baskets mixed fish	Good marks most of the drag
	5	1640-1825	45110.5 60910.2	45118.5 60908.0	7 Grouper 4 Baskets mixed fish	Good fish marked at 45111.8 60911.8
	6	1850-2040	45115.9 60909.3	45116.0 60911.0	2 Grouper 5 Baskets mixed fish	-----
4-7-83	1	0610-0815	45120.3 60908.4	45110.0 60912.0	1 25 lb. Red snapper 2 Grouper 4 Baskets mixed fish	-----
	2	0845-1100	45115.2 60913.5	45112.9 60918.0	6 10 lb. Red snapper 3 Grouper 2 Baskets mixed fish	-----
	3	1130-1300	45114.1 60909.5	45119.8 60910.3	2 Red snapper (1g) 5 Grouper 2 Baskets mixed fish	-----

Appendix E. M/V CAPT. MERRITT Log, Trip No. 2
Roller-Rigged Fish Trawling (cont'd.)

Date	Tow No.	Time of tow (E.S.T.)	Set location	Haul location	Catch	Notes	
4-7-83	4	1340-1520	45118.9 60914.0	45118.0 60918.0	2 Red snapper (1g) 5 Grouper 1 Basket mixed fish	-----	
	5	1540-1715	45116.8 60921.1	45111.0 -----	5 Red snapper (sm) 1 Grouper (1g) 4 Grouper (sm) 1 Basket mixed fish	-----	
	6	1745-1930	45113.5 60910.7	45119.6 60909.7	2 Red snapper (1g) 1 Grouper (1g) 1 Grouper (sm) 4 Baskets mixed fish	-----	
	7	1945-2130	45121.4 60907.8	45120.4 60910.2	1 Red snapper (1g) 2 Grouper 1-1/2 Baskets mixed fish	-----	
	4-8-83	1	0635-0835	45120.7 60904.3	45121.0 60904.0	2 Grouper (1g) 2 Grouper (sm) 2 Baskets mixed fish	-----
		2	0900-0925	45121.5 60904.5	45128.0 60882.4	3 Grouper (1g) 1 Grouper (sm) 1 Basket mixed fish	Steep ledge at haul back location
		3	1040-1235	45129.6 60877.5	45135.0 60840.0	1 Red snapper (1g) 6 Grouper (1g) 1 Basket mixed fish	-----
4		1255-1455	45134.4 60840.6	45136.0 60840.0	3 Red snapper (1g) 20 Grouper (1g) 4 Grouper (sm) 4 Baskets mixed fish 1 Grey tilefish	-----	

Appendix E. M/V CAPT. MERRITT Log, Trip No. 2
 Roller-Rigged Fish Trawling (cont'd.)

<u>Date</u>	<u>Tow No.</u>	<u>Time of tow (E.S.T.)</u>	<u>Set location</u>	<u>Haul location</u>	<u>Catch</u>	<u>Notes</u>
4-8-83	5	1515-1730	45136.2	45141.7	2 Red snapper	-----
			60838.5	60849.9	7 Grouper (lg) 3 Grouper (sm) 2 Baskets mixed fish	
	6	1750-2035	45143.0	45131.5	2 Red snapper (lg)	-----
			60842.1	60864.3	5 Grouper 1 Basket mixed fish	
4-9-83	1	0625-0845	45140.2 60845.1	45137.5 60852.8	1 Grouper 1 Basket mixed fish	Tore bottom out of net

Appendix E. M/V CAPT. MERRITT Log, Trip No. 3
 Roller-Rigged Fish Trawling

<u>Date</u>	<u>Tow No.</u>	<u>Time of tow (E.S.T.)</u>	<u>Set location</u>	<u>Haul location</u>	<u>Catch</u>	<u>Notes</u>
4-13-83	1	0810-1010	45137.7 60857.6	45138.0 60844.0	5 Grouper (lg) 2 Grouper (sm) 1/2 Basket mixed fish	Good fish marked at 45139.8 60844.9
	2	1115-1350	45142.5 60834.7	45140.8 60838.9	1 Red snapper (sm) 17 Grouper (lg) 17 Grouper (sm) 2 Baskets mixed fish	Good fish marked at 45139.5 60843.1
	3	1420-1640	45143.1 60833.4	45135.3 60832.6	2 Red snapper (sm) 10 Grouper (lg) 8 Grouper (sm) 1/2 Basket mixed fish	320 ft. deep
	4	1715-2000	45136.4 60825.9	45143.3 60829.2	3 Red snapper (lg) 1 Red snapper (sm) 6 Grouper (lg) 2 Grouper (sm) 2 Baskets mixed fish	-----
4-14-83	1	0635-0925	45142.0 60860.0	45143.3 60838.9	1 Red snapper (lg) 8 Grouper (lg) 2 Grouper (sm) 2 Baskets mixed fish	-----

Appendix E. M/V CAPT. MERRITT Log, Trip No. 3
 Roller-Rigged Fish Trawling (cont'd.)

<u>Date</u>	<u>Tow No.</u>	<u>Time of tow (E.S.T.)</u>	<u>Set location</u>	<u>Haul location</u>	<u>Catch</u>	<u>Notes</u>
4-14-83	2	0950-1040	45144.0 60838.8	45139.0 60845.8	2 Grouper (lg) 1/2 Basket mixed fish	Marked good fish at 45139.7 60845.1 hung at haul back location, minor net damage
	3	1300-1600	45143.5 60846.8	45142.8 60835.7	1 Snapper (lg) 1 Grouper (lg) 1/2 Basket mixed fish	-----
	4	1625-2000	45142.8 60835.7	45128.3 60882.3	1 Red snapper 6 Grouper 1 Basket mixed fish	Bad weather, heading home

Appendix E. M/V CAPT. MERRITT Log, Trip No. 4
Roller-Rigged Fish Trawling

Date	Tow No.	Time of tow (E.S.T.)	Set location	Haul location	Catch	Notes
4-25-83	1	0610-0745	45119.5 60902.3	45115.2 60904.9	Nothing caught	Hang, tore net
4-26-83	1	0530-0725	45137.4 60854.6	45142.5 60845.5	3 Cobia 1 King mackerel 2 Grouper (lg) 1/2 Basket mixed fish	-----
	2	0745-0830	45146.4 60848.7	45139.5 60846.2	1 Grouper (sm) 1/2 Basket mixed fish	Hung up on haul back location, no damage
	3	0930-1145	45135.7 60832.4	45137.7 60832.5	3 Red snapper (lg) 9 Grouper (lg) 6 Grouper (sm) 1-1/2 Baskets mixed fish	Marked good fish at 45136.1 60833.9
	4	1205-1445	45140.0 60832.1	45141.1 60837.9	4 Grouper (lg) 3 Grouper (sm) 1/2 Basket mixed fish	-----
	5	1500-1710	45146.0 60833.6	45130.2 60865.6	1 Red snapper (lg) 1 Grouper (lg) 1 Grouper (sm)	-----
	6	1730-2030	45131.0 60868.5	45111.1 60915.0	3 Red snapper (lg) 1 Red snapper (sm) 1 Grouper (lg)	-----
4-27-83	1	0730-0930	45111.0 60920.4	45114.6 60913.7	3 Grouper (lg) 2 Grouper (sm)	-----
	2	0950-1200	45120.5 60912.9	45124.4 60909.0	1 Grouper (sm)	-----

Appendix E. M/V CAPT. MERRITT Log, Trip No. 4
 Roller-Rigged Fish Trawling (cont'd.)

Date	Tow No.	Time of tow (E.S.T.)	Set location	Haul location	Catch	Notes
4-27-83	3	1240-1440	45132.1 60857.7	45142.0 60851.4	2 Red snapper (lg) 1 Grouper (lg) 3 Grouper (sm)	-----
	4	1515-1725	45141.9 60853.1	45141.9 60842.8	2 Red snapper (lg) 4 Grouper (lg) 6 Grouper (sm)	-----
4-28-83	1	0650- ?	45142.8 60843.6	----- -----	Nothing caught	Had to pick up, tide too bad to tow, Full moon was April 27.
	2	1345-1445	45285.2 61228.3	45291.7 61231.3	11 Baskets B-liners 1-1/2 Baskets mixed fish	Moved inshore to the "Grand Banks" area, less tide current
	3	1625-1720	45285.3 61234.7	45289.2 61231.8	6 Red snapper (sm) 8 Baskets B-liners 1 Basket mixed fish	-----
	4	1830-1930	45284.9 61233.1	45285.4 61230.6	1 Red snapper (sm) 3 Baskets B-liners 1/2 Basket mixed fish	-----
	5	2015-2110	45288.3 61225.6	45293.6 61237.6	8 Red snapper (sm) 1 Grouper (lg) 1 Grouper (sm) 7 Baskets B-liners 1 Basket mixed fish	-----
4-29-83	1	0815-0850	45284.0 61227.6	45299.8 61247.1	4 Baskets B-liners 1/2 Basket mixed fish	-----

Appendix E. M/V CAPT. MERRITT Log, Trip No. 4
 Roller-Rigged Fish Trawling (cont'd.)

<u>Date</u>	<u>Tow No.</u>	<u>Time of tow (E.S.T.)</u>	<u>Set location</u>	<u>Haul location</u>	<u>Catch</u>	<u>Notes</u>
4-29-83	2	0905-0950	45298.9 61246.0	45292.7 61229.5	1 Red snapper (lg) 9 Baskets B-liners 1/2 Basket mixed fish	-----
	3	1015-1115	45294.5 61232.9	45285.3 61232.7	4 Baskets B-liners 1 Basket mixed fish	-----
	4	1310-1415	45285.2 61230.9	45293.9 61249.1	1 Basket Red snapper (sm) 3 Grouper (lg) 3 Grouper (sm) 6 Baskets B-liners 1 Basket mixed fish	-----
	5	1435-1615	45295.2 61252.7	45297.6 61251.2	2 Grouper (sm) 18 Baskets B-liners 1/2 Basket mixed fish	-----
	6	1945-2000	45296.7 61239.1	45293.1 61240.0	5 Baskets B-liners	-----
	7	2020-2110	45296.8 61238.6	45295.0 61242.0	2-1/2 Baskets B-liners	-----
	8	2135-2235	45298.0 61230.0	45294.5 61248.8	4 Baskets B-liners 1 Basket mixed fish	Head to dock at 2300

