

MARINE  
TECHNICAL  
REPORT  
NUMBER 94-2

**Recruitment of  
*Crassostrea virginica*:  
A Tool for Monitoring  
the Aquatic Health of  
the Sapelo Island  
National Estuarine  
Research Reserve**

Francis X. O'Beirn  
Peter B. Heffernan  
Randal L. Walker



The University of Georgia

School of Marine Programs  
Athens, Georgia

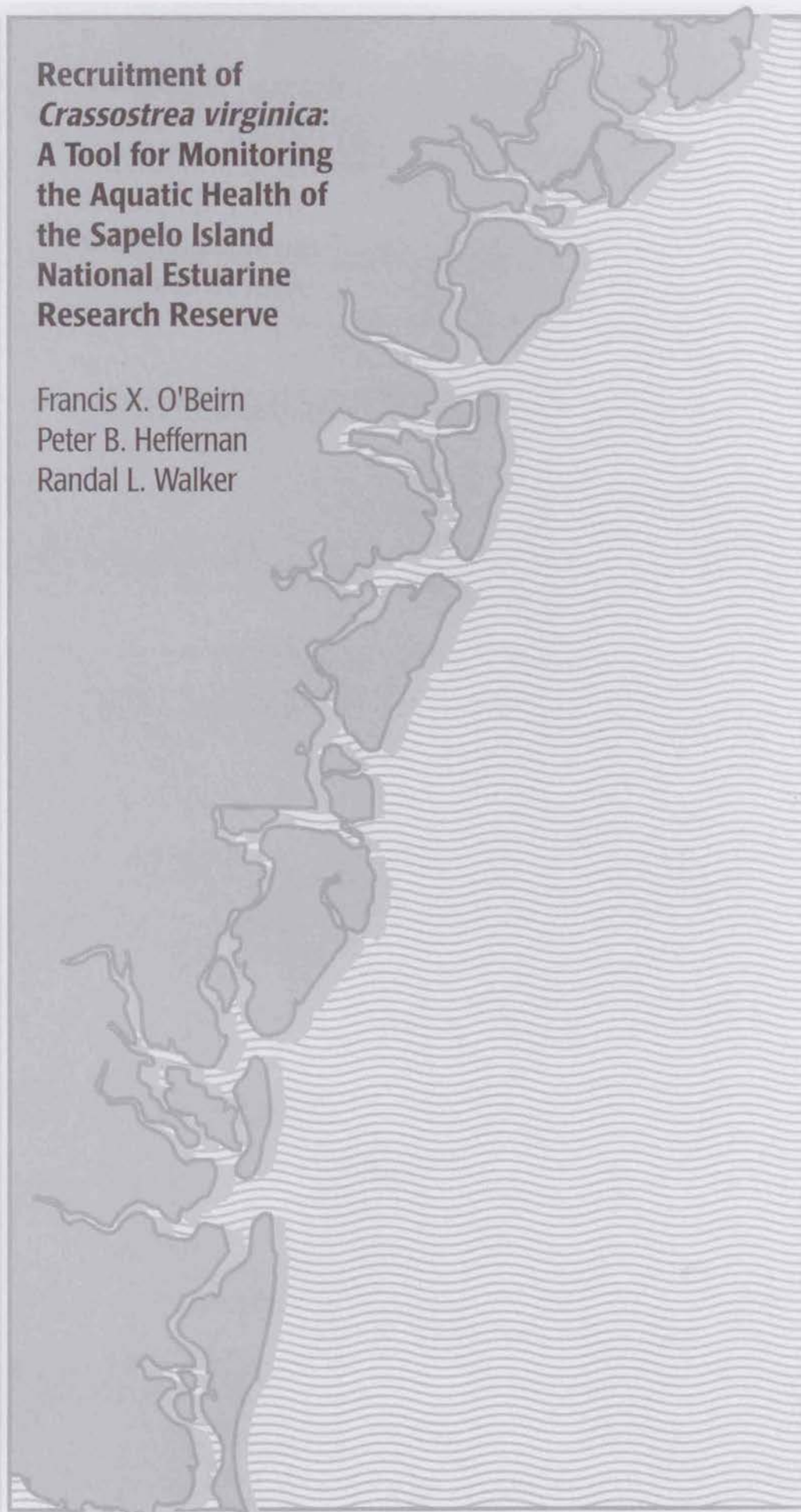

Recruitment of *Crassostrea virginica*: A Tool for Monitoring  
the Aquatic Health of the Sapelo Island National  
Estuarine Research Reserve

Francis X. O'Beirn

Peter B. Heffernan

Randal L. Walker

The Technical Report Series is issued by The University of Georgia. It was established to provide dissemination of technical information and progress reports resulting from marine studies and investigations mainly by staff and faculty of The University System of Georgia. In addition, it is intended for the presentation of techniques and methods, reduced data, and general information of interest to industry, local, regional, and state governments and the public. Information contained in these reports is in the public domain. If this pre-publication copy is cited, it should be cited as an unpublished manuscript.



## **Acknowledgements**

We wish to thank Dr. J. Alberts, Dr. A. Chalmers, Ms. J. Mensler and the staff of The University of Georgia Marine Institute for their cooperation throughout the course of this study. The assistance of the Georgia Department of Natural Resources is also acknowledged. The authors would also like to thank Nicholas Pfeiffer for helping set up the study and Ms. Anna Boyette for her assistance with the graphics. The comments of three anonymous reviewers are greatly appreciated. This work was supported by USDC NOAA, Grant No. 2731RE337-049, (Sapelo Island National Estuarine Research Reserve) and Georgia Sea Grant No. NA84AA-D-00072.

The views expressed herein are those of the authors and do not necessarily reflect the views of NOAA or any of its sub-agencies. Printing costs were funded by Georgia Sea Grant No. NA26RG0373-01.

## **Abstract**

Recruitment levels of the eastern oyster, *Crassostrea virginica* (Gmelin, 1791), were evaluated on the Duplin River within the Sapelo Island National Estuarine Research Reserve, and the results were used to establish a data base to monitor system health. Three sites were chosen (Marsh Landing, Jack Hammock, and Flume Dock) which together encompassed much of the Duplin River. Sampling occurred on a monthly basis and at the end of the setting season. Settlement commenced in June, peaked in August (with a maximum density of spat of 35,000 spat per square meter, i.e., 350 spat/0.01m<sup>2</sup>), and ceased in October/November. The density values were high and comparable to levels experienced in Wassaw Sound, GA, which were obtained employing similar techniques. Within the Duplin River, settlement levels varied considerably among the sites. Highest recruitment estimates occurred subtidally or at the low water mark for the monthly sampling and intertidally for the seasonal samples. The shift has been attributed to predation on the newly settled forms. Some implications for fishery management and ecosystem monitoring are discussed.

**Keywords:** bivalve, oyster, coast, estuary, fishery, mollusc, recruitment, resource, saltmarsh, stock

## List of Figures

- Figure 1. Map of coastal Georgia, indicating the two sampling regions. p.25
- Figure 2. Map of the Duplin River; indicating the three sampling sites: 1-Marsh Landing, 2-Jack Hammock, 3-Flume Dock. p.26
- Figure 3. Collecting apparatus used in this study. p.27
- Figure 4. Monthly data from the Duplin River & Wassaw Sound sites, 1993. Spaces between the names on the sites axis indicate the Tukey groupings ( $p < 0.001$ ) \* Note: July sample for Marsh Landing is missing. p.28
- Figure 5. Settling season cumulative recruitment data for the Duplin River and Wassaw Sound sites, 1993. Spaces between the names on the sites axis indicate the Tukey groupings. Given also are the Tukey groupings for the tidal heights within each site. p.29

## **List of Tables**

Table 1.	Results of the ANOVA and Tukey test for the pooled monthly data, Duplin River.	p.30
Table 2.	Results of the ANOVA and Tukey test for the monthly data, Duplin River.	p.31
Table 3.	Results of the ANOVA and Tukey test for the seasonal data, Duplin River.	p.33
Table 4.	Results of the ANOVA and Tukey test for the pooled monthly data, Wassaw Sound.	p.34
Table 5.	Results of the tidal height analysis from pooled monthly data, Wassaw Sound.	p.35
Table 6.	Pooled monthly size data (mm±SE), Duplin River and Wassaw Sound.	p.36

## Table of Contents

Acknowledgements.....	i
Abstract.....	ii
List of Figures.....	iii
List of Tables.....	iv
Table of Contents.....	v
Introduction.....	1
Site Description.....	5
Materials and Methods.....	6
Results.....	9
Discussion.....	11
Conclusion.....	16
References.....	19
Figures.....	25
Tables.....	30
Appendix-1.....	37
Appendix-2.....	39

## **Introduction**

The Georgia coastline, approximately one-hundred-miles long, is composed of almost 161,900 hectares of marsh (Spinner, 1969), bordered by land to the west and barrier islands to the east. Within this marsh system is an extensive network of rivers, streams and creeks, all of which are under some degree of tidal influence. The Sapelo Island National Estuarine Research Reserve (SINERR), located midway along the Georgia coast, was established in 1976 and was designated as an area for scientific research and education. The Duplin River (within the SINERR) and surrounding salt marsh areas have since provided an ideal area for the study of marsh ecosystem dynamics. The region, which typifies most of coastal Georgia's wetlands, is largely undeveloped and relatively pristine. Along many of the creeks and tributaries of coastal Georgia and the SINERR marsh system, the eastern oyster, *Crassostrea virginica* (Gmelin 1791), is prevalent and located predominantly in the littoral zone, either in the form of loose beds or more commonly as oyster reefs. The reefs are formed by the continued abundant setting of oyster larvae on existing oysters. The subsequent growth of the individual oysters is restricted and results in an elongation of the shells. Hence, the growth of the reefs are lateral and not horizontal

(McKenzie and Badger, 1969; Adams *et al.*, 1991).

Oysters have been used worldwide as indicators of the health of aquatic systems and their surrounding waters. In studies from Nova Scotia, (Lakshminarayana and Jonnavithula, 1989), the Gulf of Mexico, (Lytle and Lytle, 1990), Japan, (Kiiyukia *et al.*, 1989) and France, (Claisse, 1989), oysters have been used as bioindicators for ecosystem and fishery management purposes. Oysters are suitable for this role because of their sessile nature, abundance and feeding behavior. As suspension feeders, they may accumulate toxic substances and pathogenic organisms in their tissue. Such toxins and other more natural disturbances (drastic salinity and temperature changes) elicit a direct or indirect response in the oyster. Directly, a change in ambient conditions may result in mortality or reduced growth or may affect the condition of the oyster tissue (Scott and Lawrence, 1982; Crosby, 1988). Indirectly, a change may increase the oysters' susceptibility to protozoan parasites such as *Perkinsus* (= *Dermocystidium*) *marinus*, "Dermo" and *Haplosporidium nelsoni*, "MSX," (Abbe and Sanders, 1988). Dermo and MSX have been recorded in Georgia waters (Lewis *et al.*, 1992). At sub-lethal levels, these pathogens have been documented to significantly reduce the physiological condition and

reproductive capacity of infected oysters (Soniati and Koenig, 1982; Barber *et al.*, 1988; Crosby and Roberts, 1990). A change in ambient conditions may also affect oyster larval viability and perhaps their subsequent survival. Oyster larvae have been used for toxicity testing in laboratory situations (Wikfors and Ukeles, 1982; His *et al.*, 1984; Robert and His, 1985; His and Robert, 1987) and to monitor the effects of toxins in natural systems (Phelps and Mihursky, 1986; Couch and Hassler, 1989). Variations in temperature, and to a greater extent salinity, have been shown to inhibit larval development and reduce spatfall (Lutz *et al.*, 1970; Hidu and Haskin, 1971; Feeny, 1984; Newell *et al.*, 1989; Roland and Broadley, 1989).

The dynamics of the oyster larvae provide the basis for a highly effective way of detecting fluctuations in an aquatic environment, whether they are naturally or anthropogenically induced. Using oyster settlement and recruitment data to monitor the health of the Duplin River will enable scientists to establish a set of baseline data over subsequent spawning periods. These data can then be used as a reference with which to detect the change in numbers of oysters recruiting within the region. If such a change occurs, then the causes can be investigated. As previously

mentioned, it has been demonstrated that pollution and natural fluctuations in environmental balances influence the physiological condition of adult oysters, larval survival and subsequent recruitment rates. The waters of the Duplin River, as well as the marshes in coastal Georgia, are subject to seasonal fluctuations in salinity and temperature. It is assumed that oysters have adapted to such fluctuations by virtue of their proliferation as well as the very high settlement rates encountered (Adams *et al.*, 1991; O'Beirn *et al.*, in prep).

Overall, the potential benefits of this study will have both ecological and fishery management implications for the reserve. Ecologically this investigation will determine natural variabilities in recruitment patterns of a prominent invertebrate species, as well as elucidate some of the factors specific to the region that influence species' survival and procreation. The recruitment levels established on the Duplin River system will also be compared to a similar ongoing study in Wassaw Sound, Georgia. The spat recruitment "indicator" will be a powerful and sensitive tool, given the extremely high densities of oyster recruitment common to both Georgia (Stevens, 1983; Adams *et al.*, 1991) and South Carolina (Kenny *et al.*, 1990). The potential for a regional (SE United States) and

possibly national role for such an indicator tool is significant, due to the prominence of oysters throughout the Atlantic and Gulf Coasts of the United States. This study will also provide a much needed long-term data base allied to continued hydrographic monitoring, which regulatory agencies could utilize to establish practical guidelines for oyster fishery management in the SE United States.

### **Site Description**

The work was carried out on the Duplin River within the Sapelo Island National Estuarine Research Reserve (SINERR), Georgia (Fig. 2). The sanctuary is typical of the marsh system in coastal Georgia and covers an area in excess of 1255 hectares. The reserve is located to the west of Sapelo Island and incorporates a portion of high ground to the south and west of the island. The Duplin River is approximately 9.5 km in length and runs from north to south into Doboy Sound. It has no significant freshwater source and therefore has been referred to as an elongated tidal bay (Ragotzkie and Bryson, 1955).

Within the SINERR, the University of Georgia Marine Institute has two monitoring stations, one located at Marsh Landing and the other at Flume

Dock, off Moses Hammock. At each site, a Hydrolab Data Sonde I unit suspended from a float, one-meter below the water surface, measures water temperature, pH and salinity. Spat monitoring sites are established in the area adjacent to these two stations. A third site, Jack Hammock, is established in the region of Lumber Dock, which is approximately halfway between the two existing sites along the Duplin River.

## **Materials and Methods**

### *Collectors*

Recruitment was assessed using 1.9 cm diameter P.V.C. tubing. The tubes have been used commercially for both remote and natural setting practices in the NW United States and British Columbia, Canada (Roland and Broadley, 1990) and for research purposes to monitor spatfall in South Carolina (Michener and Kenny, 1991) and Georgia (O'Beirn *et al.*, unpubl. data). The grey-colored tubing had chips of calcium carbonate embedded within it and was grooved longitudinally, which gave it an overall rough texture. The mean circumference of the tubes was 8 cm. The collectors were cut in 15-cm segments, of which only 12.5 cm was used in the analysis which resulted in a sampling area of approximately 100 cm<sup>2</sup>.

At each of the three sites recruitment was estimated by counting the

number of spat on each collector at three tidal heights: subtidally, at mean low water and intertidally, at a height achieved approximately two hours after mean low water. The three tidal heights were chosen to provide a reflection of the environmental extremes to which newly set spat would be subjected, *i.e.*, from a zone of lower risk of desiccation and higher risk of predation to a zone of higher risk of desiccation and lower risk of predation (Castagna *et al.*, 1988; Gibbons and Chu, 1988). The oyster collectors (grey P.V.C. tubing) were slipped over 1.25 cm P.V.C. rods in the order required by the desired tidal height (Fig. 3). Spacers (2 cm diameter schedule 40 P.V.C.) dividing collectors at each tidal height, were employed between the collectors. Five rods were arrayed on a schedule 40 P.V.C. (3.8 cm diameter) portable frame which was then suspended vertically from a frame constructed from schedule 40 P.V.C. (5 cm diameter) at each of the sites. At each tidal height and for each group of five replicates, the shell height of 30 randomly selected oysters (whenever possible) was measured with Vernier calipers from the umbo to the furthest point on the shell margin.

### *Sampling Regime*

Two sampling regimes were employed at each site. The regimes were

monthly (five units replaced on a monthly basis) and seasonal (five units left on site for the duration of the study). By establishing the different sampling periods, it was possible to estimate any changes in oyster distribution over these two temporal scales, i.e., short-term and long-term recruitment patterns (Michener and Kenny, 1991). Doing so would help elucidate the most suitable time and duration for the deployment of collectors. Knowledge of peak recruitment periods would also determine the sites and tidal heights that would optimize oyster set and survival for those interested in the collection of natural spat.

### *Statistical Analyses*

As a result of the substantial variations in the means and variances of recruitment numbers over time, all of the raw data for estimates of oyster numbers per 0.01m<sup>2</sup> were log transformed. Analysis of Variance (ANOVA) and Tukey Studentized Range Tests (using PC SAS, SAS Inst. Inc., 1989) were performed on the data comparing the total numbers of oysters retrieved over the sampling period among the three sites. ANOVAs were performed on the data from the tidal heights at each site for the monthly and seasonal sampling regimes. ANOVAs were also carried out on the size data (whenever possible) comparing animal sizes at each tidal height for

each of the sampling regimes. It was hoped to ascertain from the statistical analyses where and when recruitment occurred within the study area, and whether there were differences in recruitment levels at the three tidal heights over the sampling regimes. Furthermore, analysis of the size data was expected to ascertain where, on an intertidal gradient, the young oysters grew fastest given the assumption that all of the animals along such a gradient settled in and around the same time.

## **Results**

Oysters were first recorded on the Duplin River on June 26th, 1992, at all three of the sites (Fig. 4). All three sites had peak recruitment in August (Marsh Landing,  $\bar{x}=344\pm60SE/0.01m^2$ ; Jack Hammock,  $\bar{x}=350\pm43SE/0.01m^2$ ; and Flume Dock,  $\bar{x}=0.4\pm0.23SE/0.01m^2$ ; Fig. 4). After the August sampling, settlement at the three sites tapered off considerably. Oyster larval settlement ceased at the Flume Dock site by October and at the other two sites by November (Fig. 4). The Analysis of Variance (ANOVA) of the pooled data over the entire sampling season revealed significant differences among the sites. The Marsh Landing and Jack Hammock sites had significantly higher settlement than the Flume Dock site ( $p<0.0001$ ; Table 1). ANOVA's carried out on the data for each month showed similar overall

patterns. Neither of the two high settlement sites (Marsh Landing and Jack Hammock) achieved consistently higher recruitment than the other (Table 2). Similar results were obtained for the seasonal data (Fig. 5). Marsh Landing and Jack Hammock had significantly higher settlement than the Flume Dock site ( $p=0.0018$ ; Table 3). The tidal height analysis of spat numbers for each of the three Duplin River sites, (Marsh Landing, Jack Hammock and Flume Dock) delineated no differences ( $p=0.0888$ ,  $p=0.0644$  and  $p=0.4582$ , respectively).

From a comparative perspective, the Wassaw Sound sites, located approximately 80 km north of Doboy Sound (Fig. 1), had higher overall settlement than the Duplin River sites ( $p=0.0015$ ). Settlement was first recorded, on the monthly collectors, in June at the three Wassaw sites and continued until it peaked in August, which was similar to the patterns exhibited in the Duplin River. The tidal height data revealed a variety of differences in tidal height data among the three sites (House Creek, Priest Landing and Skidaway River; see Table 5). At all three sites values for the entire settlement season had consistently higher recruitment intertidally than at the other two tidal heights.

The shell height (SH) data for the pooled monthly data for each of the

Duplin River sites revealed significant differences at all three sites (Table 6). Marsh Landing low-water and subtidal SH values were significantly larger than the intertidal SH values ( $p=0.0049$ ). Jack Hammock had subtidal SH values significantly greater than the low-water SH values, which in turn were greater than the intertidal SH values ( $p=0.0001$ ). The Flume Dock SH values had significantly higher subtidal sizes than the intertidal SH values. Neither differentiated from the low-water SH values ( $p=0.0531$ ). All these results were as expected, with the collectors immersed for longer periods of time realizing larger animals.

## **Discussion**

One of the primary objectives of this study was to establish a data base of oyster settlement levels within the Duplin River, which is part of the Sapelo Island National Estuarine Research Reserve. These data will then be used as an indicator of system health and will help discriminate between natural fluctuations and anthropogenically induced changes. The SE United States are prone to hurricanes and large storms from July through October (which coincides with the spawning and settlement season of the oysters). Such a storm could impact the oysters directly by physical destruction or indirectly by reducing salinities and thereby stressing the settled and

larval forms. A storm could irretrievably wash oyster larvae out of the system as well as increase the sediment and silt loading of the Duplin River. Both factors would reduce the system recruitment rates as well as detrimentally impact the existing adult population and associated fauna.

Examples of direct anthropogenic sources are oil or fuel spills from boats. While the Duplin River is subjected to heavy boat traffic, most of it is recreational. However, logging and fuel barges do use the river with some frequency. Heavy shrimping activity in Doboy Sound is another possible source of oil spills. If a substantial spill were to occur, it could have a direct detrimental effect on the oysters, either by killing them or impacting their health, thereby diminishing their reproductive capabilities. An increase in stress on the oyster will also make it more prone to parasitic organisms, such as *Perkinsus marinus*, which was recorded in the Duplin River as far back as 1966 (Lewis *et al.*, 1992). An increase in the prevalence of the parasites could reflect system disturbance.

The oyster spawning/settlement season in coastal Georgia, which was delineated using gametogenic analysis by Heffernan *et al.* (1989) and

larval settlement by O'Beirn *et al.* (unpubl. data), extends from May through October. The duration of the oyster settlement in the Duplin River concurs with these previous studies and recruitment patterns also agree with one of the aforementioned studies of settlement on a similar temporal scale, i.e., O'Beirn *et al.* (unpubl. data). Such a pattern can be described by a continual buildup of recruitment levels to a peak in August, after which there is a precipitous decline and cessation in October or November.

While settlement at the two southernmost sites (Marsh Landing and Jack Hammock) was comparable and high, the settlement levels obtained for the northernmost site (Flume Dock) were erratic and significantly lower than the others (Fig. 4). In fact, in July and August, the mean levels for Marsh Landing and Jack Hammock were two orders of magnitude higher than the Flume Dock site (Appendix 1). The explanation for such anomalous results are not attainable within the framework of this study. However, the authors can speculate regarding some of the possible factors which would lead to reduced levels of oyster larval settlement further up the Duplin River. Harris (1980) conducted a "comprehensive" survey of intertidal and subtidal oyster beds in coastal Georgia. For the Duplin River he charted major oyster beds in the southern portions of the river and into

Doboy Sound. No oyster beds were mapped in the northern part of the river. However, live adult oysters do exist in the northern reaches of the river (personal observation). Yet, their numbers are low and variable such that presence of conspecifics or lack thereof, could be a factor in the paucity of larval recruitment at the Flume Dock site. Hydrography could be another factor limiting the numbers of settling oysters at the Flume Dock site. Throughout the course of the study, pH was consistently lower at the Flume Dock site; whereas, salinity and temperature readings were comparable between Flume Dock and the Marsh Landing. Loosanoff and Davis (1963) demonstrated that lower pH can result in lower survival and growth rates of the oyster larvae. Also, Ragotzkie and Bryson (1955) determined that the Duplin River and other tidal creeks on the Georgia coast may lose up to 40% of their water on an ebb tide. Such a profound exchange could easily result in complete flushing of larvae from the upper reaches of the river.

Similarities in terms of oyster recruitment patterns and numbers between the Marsh Landing and Jack Hammock sites (Tables 1,2,3) were due possibly to the two sites' proximity, similar hydrographic features, and equal number of conspecifics.

Comparatively there was little difference in duration, patterns of settlement and overall abundance of oyster set between the Duplin River and Wassaw Sound, throughout the season. One difference that was observed however, was that settlement commenced earlier in the Wassaw Sound area than in the Duplin River. It is speculated that the reason for the earlier Wassaw set is that water temperatures were higher there earlier in the year. In March both areas had similar mean temperatures (15.8°C and 15.7°C for Wassaw Sound and the Duplin River, respectively). In Wassaw Sound mean temperatures for the months April, May and June were 18.5°C, 21.9°C and 26°C, respectively compared to 17.9°C, 21.4°C and 25°C, respectively for the Duplin River. It is appreciated that a true comparison cannot be made regarding these hydrographic data sets as the values were obtained by different means. However, the values do suggest a trend of higher temperatures in Wassaw Sound which could account for an earlier spawn and recruitment.

The phenomenon encountered regarding the tidal height analysis is not new to the Georgia coastline. O'Beirn *et al.* (unpubl. data) report that after two weeks of immersion in Wassaw Sound, collectors were dominated by oyster spat at the subtidal level. After a sampling period of one month,

low-water and subtidal collectors had comparable numbers of oysters setting. After immersion for the complete season, the intertidal collectors had significantly higher numbers of oysters than the low-water or subtidal collectors. A similar pattern was observed for the monthly and seasonal sampling regimes in the Duplin River, whereby, the low-water and intertidal collectors had higher numbers of oysters, respectively. The reason for the lack of overall recruitment subtidally has been attributed to predation and other factors i.e., siltation and a lack of suitable substrate (Linton, 1968; Harris, 1980).

## **Conclusion**

This study has elucidated the levels of oyster settlement and recruitment for a single season in the Duplin River, Georgia. It also provides the basis for a continuous study within which the aforementioned parameters will be used as an index of system health. Another beneficial feature of the study is that it will augment not only the management practices for public and leased beds within the study area but also for the entire Georgia coastline. This study has shown that natural oyster settlement levels in coastal Georgia are both high and variable. Such facts are borne out by the significant differences obtained among the sites over the course of the

setting season. The highest mean settlement of 350 spat/0.01m<sup>2</sup> translates to approximately 35,000 oyster spat per square meter - a potentially valuable, and as yet, untapped resource.

Given the variety of characteristics inherent in each of the sites, it is appreciated that no clear conclusions can be drawn regarding the causality of the settlement variations within the study area. However, it is clear that the numbers of newly settled oysters at a particular tidal height within a particular site on a monthly basis, will not reflect the levels of new recruits to that same height and site on a seasonal or yearly basis. It can be inferred, however, that the intensity of mortality at each of the sites varies considerably; such a phenomenon would have to be factored into any management program that relies on the capture of natural spat subtidally. Another evaluation to be made concerns the fact that recruitment rates of oysters at some sites may not be high enough to overcome mortality rates such that the oyster population of that particular area may be in decline. It is important to note that there is critical need for the continued study of oyster settlement levels so that these natural fluctuations can be assessed more comprehensively. Such a need is evidenced by the fact that the levels experienced to date for the

1993 study are substantially lower than those reported in this study. It is anticipated that these differences are due in large part to the record high temperatures experienced on the Georgia Coast during the months of June through August, 1993. The long-term nature of the study will enable authorities to establish the causes of such variations and subsequently will help them to alleviate the problem.

## References

- Abbe, G.R. and Sanders, J.G. 1988. Rapid decline in oyster condition in the Patuxent River, Maryland. *J. Shellfish Res.* 7: 57-59.
- Adams, M.P., Walker, R.L., Heffernan, P.B. and Reinart, R.E. 1991. Eliminating spat settlement on oysters cultured in coastal Georgia: A feasibility study. *J. Shellfish Res.*, 10: 207-213.
- Barber, B.J., Ford, S.E. and Haskin, H.H. 1988. Effects of the parasite MSX (*Haplosporidium nelsoni*) on oyster (*Crassostrea virginica*) energy metabolism. I. Condition index and relative fecundity. *J. Shellfish Res.* 7: 25-32.
- Castagna, M., Gibbons, M.C. and Kurkowski, K., 1988. Remote setting and post-set strategies for growing *Crassostrea virginica* in Virginia. *J. Shellfish Res.* 7: 571-572.
- Claisse, D. 1989. Chemical contamination of French coasts. The results of a ten-year mussel watch. *Mar. Pollut. Bull.* 20(10): 523-528.
- Couch, D and Hessler, T.J. 1989. Species profiles: Life histories and environmental requirements of coastal fishes and invertebrates (Pacific Northwest). Olympia oyster. *Biol. Rep. U.S. Fish and Wildl. Serv.* 17pp.
- Crosby, M.P. 1988. Using bioenergetics of intertidal oyster populations as

- a measurement of anthropogenic perturbations to shellfish growing waters. J. Shellfish Res. 7:199-200.
- Crosby, M.P. and Roberts, C.F. 1990. Seasonal infection intensity cycle of the parasite *Perkinsus marinus* (and an absence of *Haplosporidium spp.*) in oysters from a South Carolina salt marsh. Dis. Aquat. Org. 9: 149-155.
- Feeny, C.F., 1984. Effects of salinity on the vertical distribution of the larvae of *Crassostrea virginica* (Gmelin) and *Ostrea equestris* (Say). J. Shellfish Res. 4: 88-89.
- Gibbons, M.C. and Chu Fu-Lin E., 1988. Does tidal zonation affect the intensity and incidence of *Perkinsus marinus* in juvenile American oysters in Virginia? J. Shellfish Res. 7: 572.
- Harris, D.C., 1980. Survey of the intertidal and subtidal oyster resources of the Georgia coast. Georgia Dept. of Nat. Resour., Coast. Resour. Div., (Project no. 2-234-R). Brunswick, GA. 44pp.
- Heffernan, P.B., Walker, R.L. and Carr, J.L., 1989. Gametogenic cycles of three marine bivalves in Wassaw Sound, Georgia: II. *Crassostrea virginica* (Gmelin, 1791). J. Shellfish Res. 8: 61-70.
- Hidu, H. and Haskin, H.H. 1971. Setting of the American oyster related to environmental factors and larval behavior. Proc. Natl. Shellfish.

Assoc. 61: 35-50.

His, E., Maurer, D. and Robert, R. 1984. Abnormalities in the reproduction of *Crassostrea gigas* (Thunberg) in Bay of Arcachon: Complementary observations. Rev. Trav. Inst. Peches Marit., Nantes. 48: 45-54.

His, E. and Robert, R. 1987. Comparative effects of two antifouling paints on the oyster *Crassostrea gigas*. Mar. Biol. 95: 83-86.

Kenny, P.D., Michener, W.K. and Allen, D.M., 1990. Spatial and temporal patterns of oyster settlement in a high salinity estuary. J. Shellfish Res. 9: 329-339.

Kiiyukia, C., Venkateswaran, K., Navarro, I.M., Kawakami, H. and Hashimoto, H. 1989. Seasonal distribution of *Vibrio parahaemolyticus* serotypes along the oyster beds in Hiroshima coast. J. Fac. Appl. Biol. Sci. Hiroshima Univ. 28(1-2): 49-61.

Lakshminarayana, J. and Jonnavithula, S.D. 1989. Heavy metals concentration in coastal and marine waters of New Brunswick, Nova Scotia and Prince Edward Island, Canada. The Global Ocean. Vol. 2: 360-365.

Lewis, E.J., Kern, F.G. Rosenfield, A., Stevens, S.A., Walker, R.L. and Heffernan, P.B. 1992. Lethal parasites in oysters from coastal Georgia with discussions of disease management implications.

- Mar. Fisheries Rev. 54(2): 1-6.
- Linton, T.L. 1968. Feasibility studies of raft culturing oysters in Georgia.  
In: Linton, T.L. (ed). Proceedings of the Oyster Culture Workshop,  
July 11-13, 1967. Univ. of Ga. and Ga. Game and Fish Comm., Mar.  
Fish. Div., Contrib. Ser. No. 6: 69-73.
- Loosanoff, V.L. and Davis, H.C. 1963. Shellfish hatcheries and their future.  
Comm. Fish. Review 25(1): 1-11.
- Lutz, R.A., Hidu, H. and Drobeck, K.G., 1970. Acute temperature increase as  
a stimulus to setting in the American oyster, *Crassostrea*  
*virginica* (Gmelin). Proc. Natl. Shellfish. Assoc., 60: 68-71.
- Lytle, T.F. and Lytle, J.S. 1990. Heavy metals in the eastern oyster,  
*Crassostrea virginica*, of the Mississippi Sound. Bull. Environ.  
Contam. Toxicol. 44(1): 142-148.
- McKenzie, M.D. and Badger, A.C. 1969. A systematic survey of intertidal  
oysters in the Savannah River basin area of South Carolina.  
Contrib. Bears Bluff Lab., No. 50: 15pp.
- Michener, W.K. and Kenny, P.D., 1991. Spatial and temporal patterns of  
*Crassostrea virginica* (Gmelin) recruitment: Relationship to scale  
and substratum. J. Exp. Mar. Biol. Ecol. 154: 97-121.
- Newell, R.I.E., Jones, T.J., Kennedy, V.S. and Alspach, S. 1989. Factors

- regulating reproduction and recruitment in populations of the eastern oyster, *Crassostrea virginica*. 8:434.
- O'Beirn, F.X., Heffernan, P.B. and Walker, R.L. Preliminary recruitment studies of the eastern oyster, *Crassostrea virginica* in coastal Georgia, and their potential applications. Submitted to Aquaculture.
- Phelps, H.L., and Mihursky, J.A. 1986. Oyster (*Crassostrea virginica*, Gmelin) spat settlement and copper in aufwuchs. Estuaries. 9(2): 127-132.
- Ragotzkie, R.A. and Bryson, R.A. 1955. Hydrography of the Duplin River, Sapelo Island, Georgia. Bull. Mar. Sci. Gulf and Carib. 5: 297-314.
- Robert, R. and His, E. 1985. Combined effects of salinity and cadmium chloride upon embryos and larvae of the Japanese oyster, *Crassostrea gigas*. Mar. Environ. Res. 15(4): 303-312.
- Roland, W.G. and Broadley, T.A., 1989. Investigation into remote setting Pacific oyster larvae. J. Shellfish Res. 8: 414-415
- Roland, W.G. and Broadley, T.A., 1990. A manual for producing oyster seed by remote setting. Extensions Systems Branch, B.C. Ministry of Agriculture and Fisheries, Victoria, B.C., Canada, 61pp.
- SAS Inst. Inc.. 1989. SAS users guide: Statistics. Version 6. SAS Institute Inc., Cary, N.C., 846pp.

- Scott, G.I. and Lawrence, D.R. 1982. The American oyster as a coastal zone pollution monitor: A pilot study. *Estuaries* 5(1): 40-46.
- Soniat, T.M. and Koenig, M.L. 1982. The effect of parasitism by *Perkinsus marinus* on the free amino acid composition of *Crassostrea virginica* mantle tissue. *J. Shellfish Res.* 2(1): 25-28.
- Spinner, G.P. 1969. A plan for the marine resources in the Atlantic coastal zone. *Am. Geogr. Soc.* 80pp.
- Stevens, S.A. 1983. Ecology of intertidal oyster reefs: food, distribution and carbon nutrient flow. Ph.D. Dissertation, Institute of Ecology, University of Georgia, Athens, GA.
- Wikfors, G.H. and Ukeles, R. 1982. Growth and adaptation of estuarine unicellular algae in media with excess copper, cadmium or zinc and effects of metal-contaminated algal food on *Crassostrea virginica* larvae. *Mar. Ecol. Prog. Ser.* 7(2): 91-106.

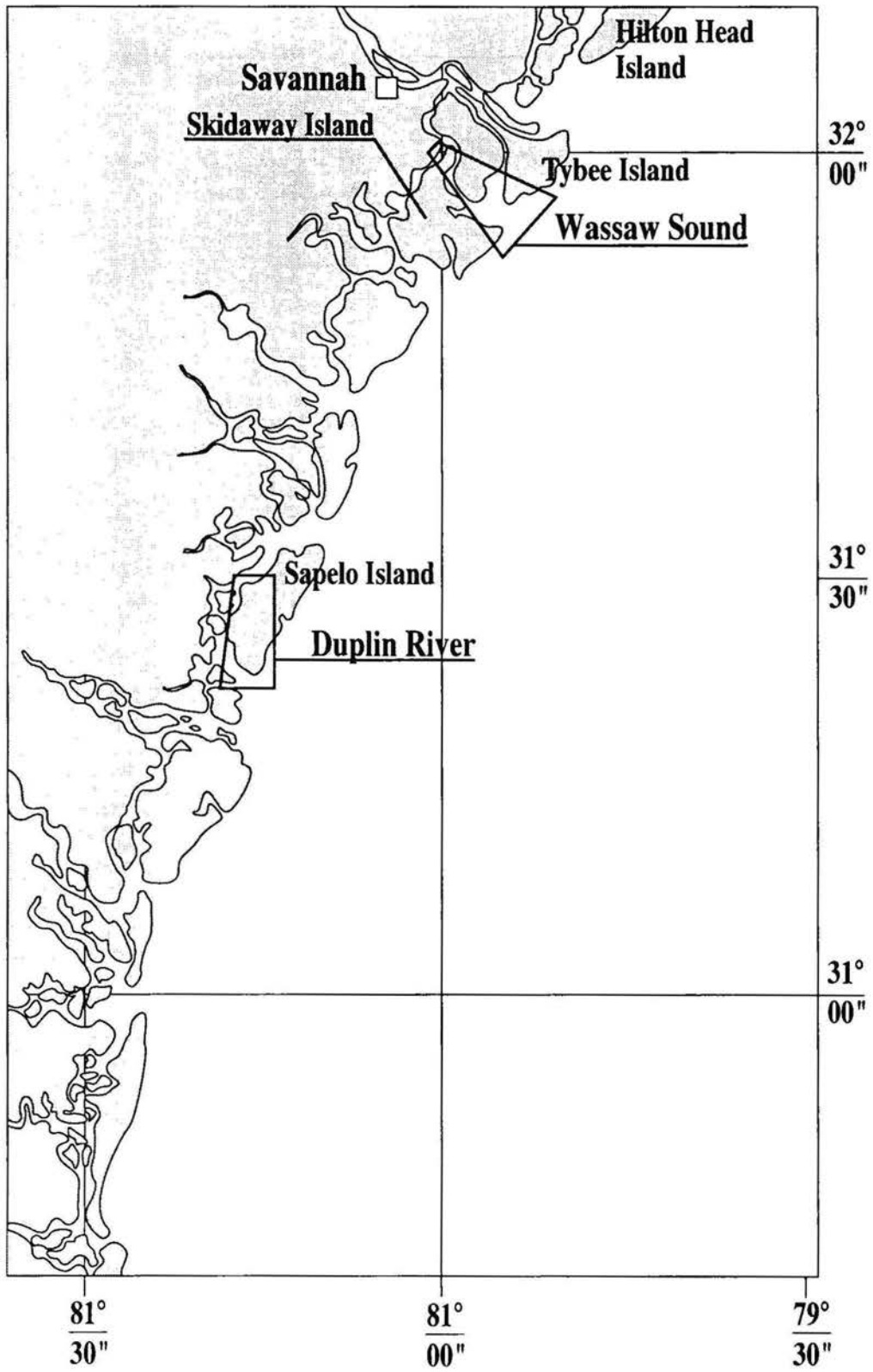

Figure 1. Map of Coastal Georgia, indicating the two sampling regions.

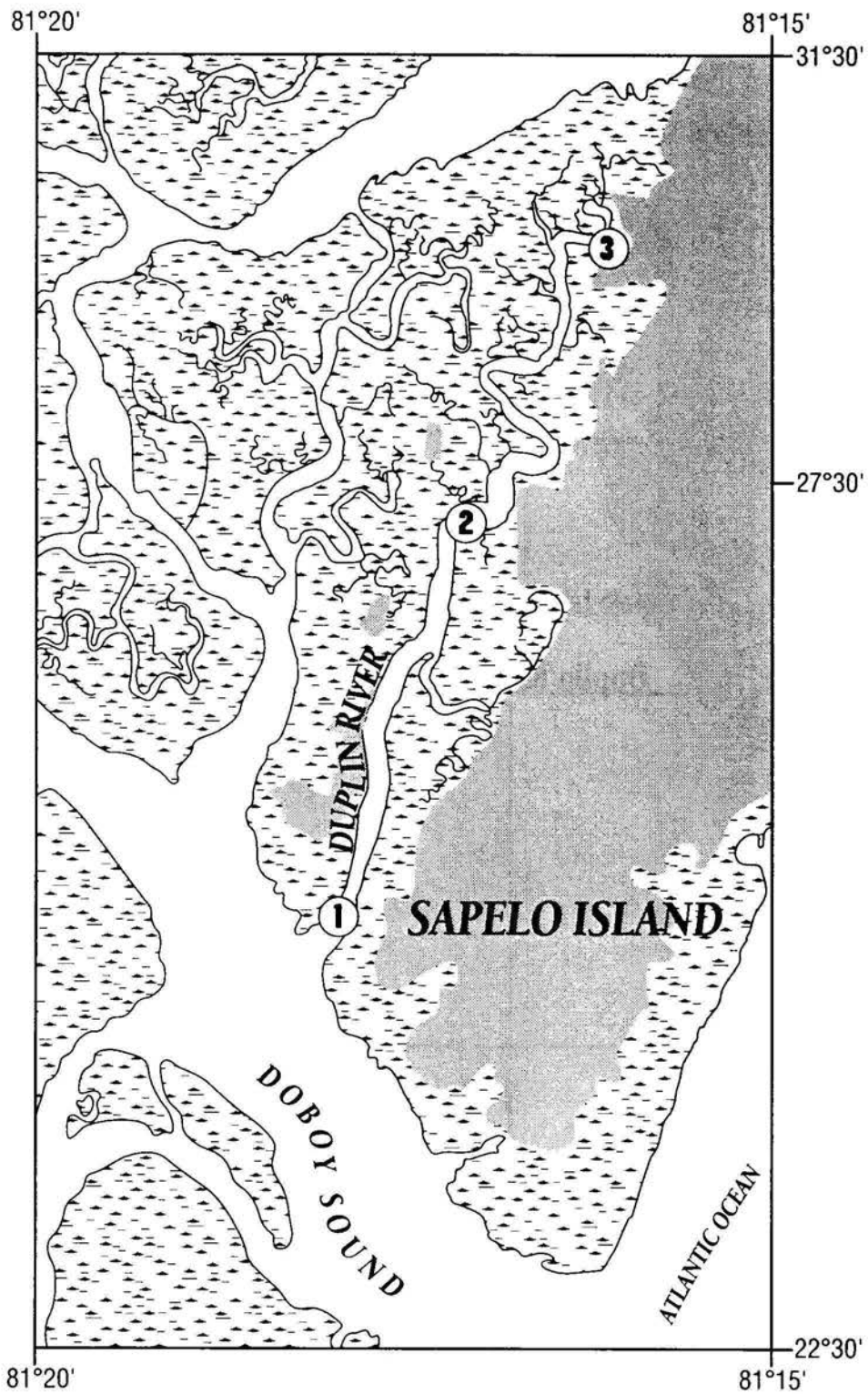

Figure 2. Map of Duplin River; indicating the three sampling sites: 1- Marsh Landing, 2- Jack Hammock, 3- Flume Dock.

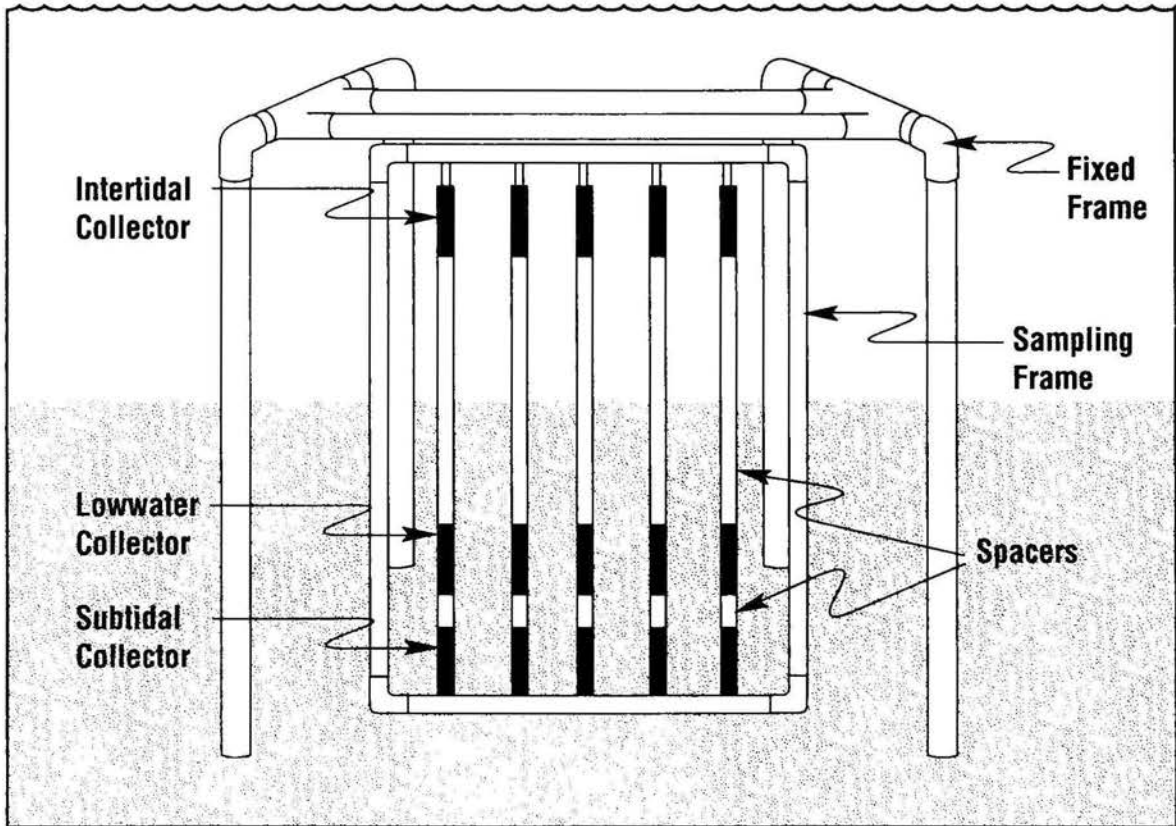

Figure 3. Collecting apparatus used in this study.

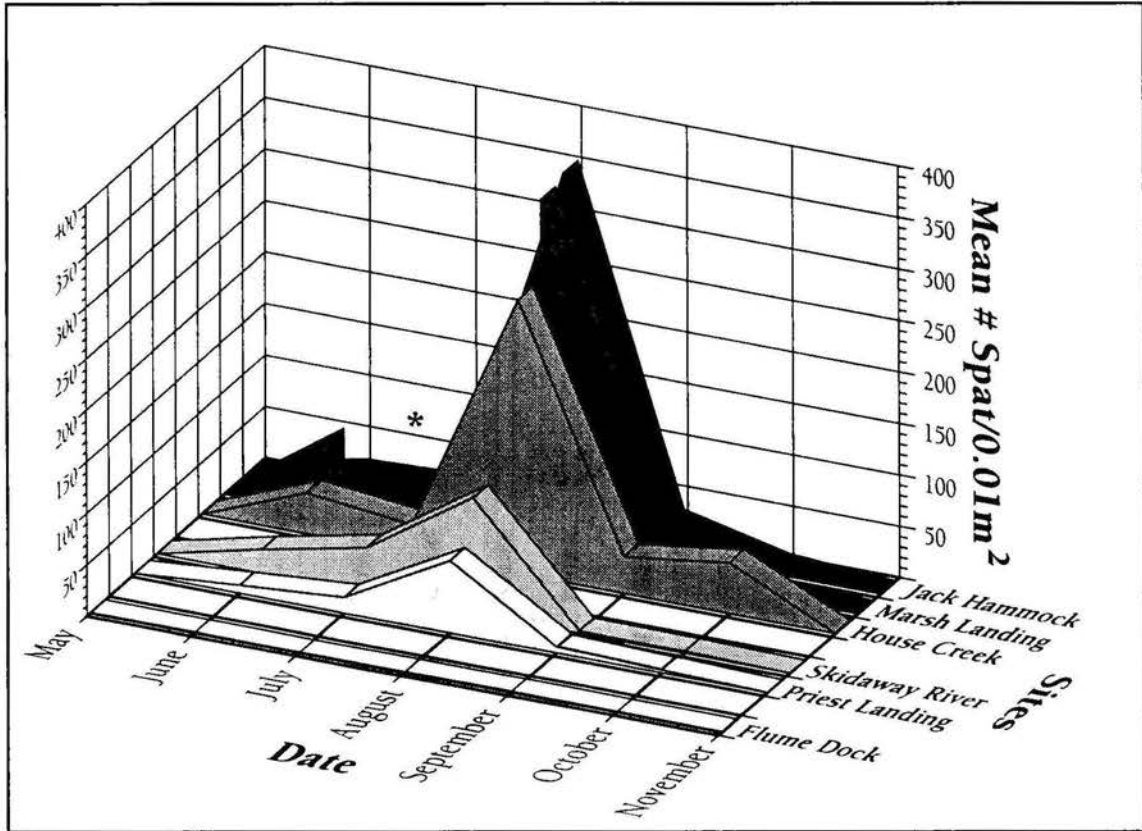

Figure 4. Monthly data from the Duplin River & Wassaw Sound sites, 1993. Spaces between the names on the "Sites" axis indicate tukey groupings ( $p < 0.0001$ ). \* Note: July sample for Marsh Landing is missing.

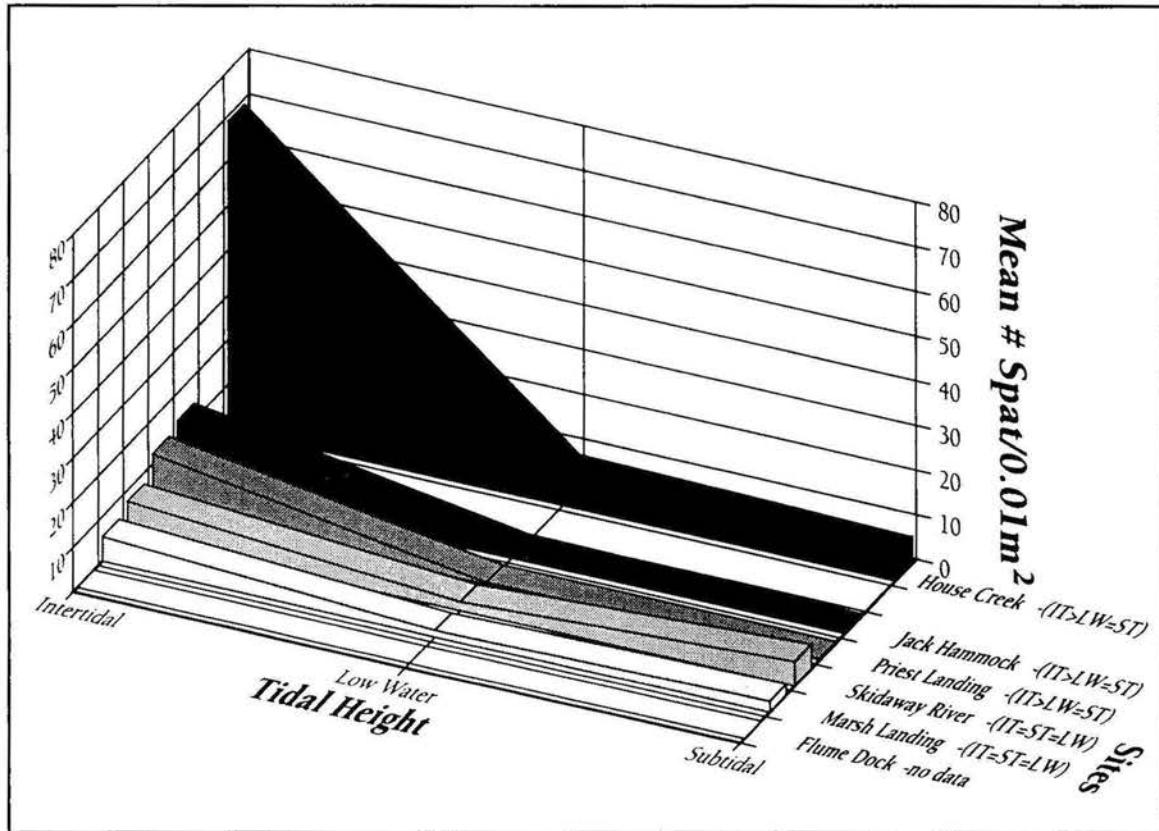

Figure 5. Settling season cumulative recruitment data for the Duplin River & Wassaw Sound sites, 1993. Spaces between the names on the "Sites" axis indicate tukey groupings. Given also are the tukey groupings for tidal heights within each site.

Table 1. Results of the ANOVA and Tukey test for the pooled monthly data\*, Duplin River.

<b><i>Marsh Landing</i></b>	<b><i>=</i></b>	<b><i>Jack Hammock</i></b>	<b><i>&gt;</i></b>	<b><i>Flume Dock</i></b>
n=90		n=90		n=90
78.1±16.5		62.2±13.1		0.12±0.04

\*Given are the number of samples (n) as well as the mean number of oysters per 0.01m<sup>2</sup> of collector plus/minus the standard error.

Table 2. Results of the ANOVA and Tukey test for the monthly data\*,  
Duplin River.

May, 1992

**\*NO SETTLEMENT**

June, 1992

<b>Marsh Landing</b>	<b>&gt;</b>	<b>Jack Hammock</b>	<b>&gt;</b>	<b>Flume Dock</b>
n=15		n=15		n=15
70.5±9.9		21.8±4.8		0.13±0.09

July, 1992 (Marsh Landing sample missing)

<b>Jack Hammock</b>	<b>&gt;</b>	<b>Flume Dock</b>
n=15		n=15
25.4±5.1		0

August, 1992

<b>Jack Hammock</b>	<b>=</b>	<b>Marsh Landing</b>	<b>&gt;</b>	<b>Flume Dock</b>
n=15		n=15		n=15
350.3±43		343.8±60.4		6±2.3

September, 1992

<b>Marsh Landing</b>	<b>=</b>	<b>Jack Hammock</b>	<b>&gt;</b>	<b>Flume Dock</b>
n=15		n=15		n=15
48±19		30±8.8		0.3±0.13

October, 1992

**Jack Hammock = Marsh Landing > Flume Dock**

n=15

n=15

n=15

7.3±1.5

6±2.0

0

November, 1992

**\* NO SETTLEMENT**

\*Given are the number of samples (n) as well as the mean number of oysters per 0.01m<sup>2</sup> of collector plus/minus the standard error.

Table 3. Results of the ANOVA and Tukey test for the seasonal data\*,  
Duplin River (p=0.0018).

<b><i>Jack Hammock</i></b>	<b><i>Marsh Landing</i></b>	<b><i>Flume Dock</i></b>
n=15	n=15	n=15
4.3±1.9	2.6±0.8	0

\*Given are the number of samples (n) as well as the mean number of oysters per  
0.01m<sup>2</sup> of collector plus/minus the standard error.

Table 4. Results of the ANOVA and Tukey test for the pooled monthly data, Wassaw Sound ( $p < 0.0001$ ).

***House Creek > Skidaway River = Priest Landing***

n=90	n=90	n=90
60±10.0	26.3±5.1	14.7±3.4

\*Given are the number of samples (n) as well as the mean number of oysters per 0.01m<sup>2</sup> of collector plus/minus the standard error.

Table 5. Results of the tidal height analysis from pooled monthly data,  
Wassaw Sound.

*House Creek, n=90, p=0.698.*

**Low Water = Subtidal = Intertidal**

*Skidaway River, n=90, p=0.0073.*

**Subtidal = Low Water > Intertidal**

*Priest Landing, n=90, p=0.0065.*

**Intertidal > Subtidal > Low Water**

Table 6. Pooled monthly shell height data (mm±SE), Duplin River and Wassaw Sound.

<b>Duplin River</b>			
	<b><i>Subtidal</i></b>	<b><i>Low Water</i></b>	<b><i>Intertidal</i></b>
<u>Marsh Landing</u>	3.9±0.33	4.1±0.30	2.9±0.23
<u>Jack Hammock</u>	4.0±0.24	2.8±0.20	1.5±0.12
<u>Flume Dock</u>	5.4±1.1	2.5±0.76	1.4±0.14
<b>Wassaw Sound</b>			
<u>House Creek</u>	2.3±0.13	2.5±0.13	2.2±0.14
<u>Skidaway River</u>	4.3±0.23	4.8±0.27	3.5±0.29
<u>Priest Landing</u>	4.3±0.26	4.0±0.25	3.9±0.20

## Appendix 1

This table gives all of the raw data means for each tidal height at each site over the complete sampling period. The mean number of oyster spat per 0.01m<sup>2</sup> of collector are given plus/minus the standard error. The minimum and maximum values of the five replicates are given in parenthesis.

<i>May, 1992</i>			
	<i>Intertidal</i>	<i>Low Water</i>	<i>Subtidal</i>
Jack Hammock			
Flume Dock	<b>*NO SETTLEMENT</b>		
Marsh Landing			
<i>June, 1992</i>			
	<i>Intertidal</i>	<i>Low Water</i>	<i>Subtidal</i>
Jack Hammock	20.2±4.9 (10, 39)	36.0±10.9 (16, 75)	9.2±3.3 (1, 19)
Flume Dock	0.2±0.2 (0, 1)	0.2±0.2 (0, 1)	0
Marsh Landing	84.8±8.6 (65, 112)	97.2±11.6 (64, 133)	29.4±12.8 (3, 70)

July, 1992

	<i>Intertidal</i>	<i>Low Water</i>	<i>Subtidal</i>
Jack Hammock	3.4±0.8 (1, 5)	33.6±4.5 (17, 43)	39.2±8.1 (20, 63)
Flume Dock	0	0	0

Marsh Landing \* MISSING COLLECTORS

August, 1992

	<i>Intertidal</i>	<i>Low Water</i>	<i>Subtidal</i>
Jack Hammock	208.4±23.9 (128, 268)	493.0±79 (319, 758)	349.0±50 (490, 349)
Flume Dock	0.2±0.2 (0, 1)	0.6±0.6 (0, 3)	0.4±0.4 (0, 2)
Marsh Landing	429.8±89 (198, 749)	526.4±41.8 (379, 628)	75.4±19.5 (16, 137)

September, 1992

	<i>Intertidal</i>	<i>Low Water</i>	<i>Subtidal</i>
Jack Hammock	5.6±0.7 (3, 7)	68.2±12.4 (41, 110)	17.8±10.3 (2, 58)
Flume Dock	0.2±0.2 (0, 1)	0.6±0.24 (0, 1)	0.2±0.2 (0, 1)
Marsh Landing	89.0±55 (1, 280)	37.8±11 (14, 78)	17.2±5.9 (4, 38)

October, 1992

	<i>Intertidal</i>	<i>Low Water</i>	<i>Subtidal</i>
Jack Hammock	3.2±1.3 (0, 8)	10.8±2.8 (5, 20)	8.0±2.7 (2, 18)
Flume Dock	0	0	0
Marsh Landing	15.6±2.8 (9, 24)	2.0±0.9 (0, 4)	0.4±0.24 (0, 1)

November, 1992

	<i>Intertidal</i>	<i>Low Water</i>	<i>Subtidal</i>
Jack Hammock			
Flume Dock		<b>* NO SETTLEMENT</b>	
Marsh Landing			

## Appendix 2

The following appendix is a description of the apparatus used in this study and is meant to augment the information already given in the Materials and Methods section of the text.

The same basic fixed-frame design was used at each of the three sites. The only variable was the length of the legs, which was dependent upon the substrate composition and the tidal regime experienced at each site, i.e., softer substrate requires longer legs to anchor the frame; also a larger tidal range usually necessitates longer legs.

The fixed frame was constructed of 5 cm diameter schedule 40 P.V.C.

The materials required for a single fixed frame are:

4x5-cm diameter Sch. 40 P.V.C. Elbows

4x5-cm diameter Sch. 40 P.V.C. T-joints

≈ 10-m x 5-cm diameter Sch. 40 P.V.C. Pipe

The materials are assembled as indicated in Figure 2 of the main text.

Consider the frame as two halves. Basically, one half will have the two elbows forming the corners which connect the legs to the main frame.

Inserted in each of the elbows horizontally are 25-cm sections of pipe which concomitantly insert into the T-joints. The T-joints are placed horizontally and will act as the inserts for the crossbars. The portable frames containing the collectors will be suspended from these crossbars.

The two T-joints with their associated structures are then connected via a 10-cm section of pipe to form one-half of the frame (Fig A). The two halves are connected by 75-cm-length piping which will complete the fixed frame.

The frame is deployed by driving the frame into the sediment. It is advisable to angle a cut at the base of the legs, thus, making it easier to drive the frame into the sediment (Fig. B).

\*Note: 1. Care must be taken when inserting the frame into the sediment to ensure that the legs do not splay, as this could weaken the structure or even crack the frame.

2. It is also advisable to drill a number of holes (2-4) into the top of the frame to avoid trapping air in the top of the frame. When covered by water, the frame will be lifted from the sediment easily by any trapped air, no matter how deeply the frame is

inserted in the substrate

The removable frame is constructed of 3.2-cm dia. Sch. 40 P.V.C. The width of the frame is approximately 75 cm. The length is dependent upon the tidal range and/or the desired tidal zone being analyzed. Each of the crossbars of the portable frame have five 2-cm holes drilled in a line on one side. These holes are spaced at 15-cm intervals. The crossbars are arranged opposite each other such that the top set of holes will face the bottom set exactly. The ascending bars of the frame are glued to the bottom crossbar and secured to the top crossbar by cable ties.

Inserted in each of the set of holes is 1.25 cm dia. C.P.V.C. (hot water piping). Five such pipes are used and their lengths are also determined by the tidal regime and/or the zones being analyzed (Fig. C).

The collectors and spacers are slipped over the five pipes in the order required by the experimenter. The pipes are inserted into the top crossbar which is in turn secured to the rest of the frame by plastic cables tied through holes drilled in the structure.

The removable frame is then suspended from the cross bars of the fixed frame using 35-cm cable ties.

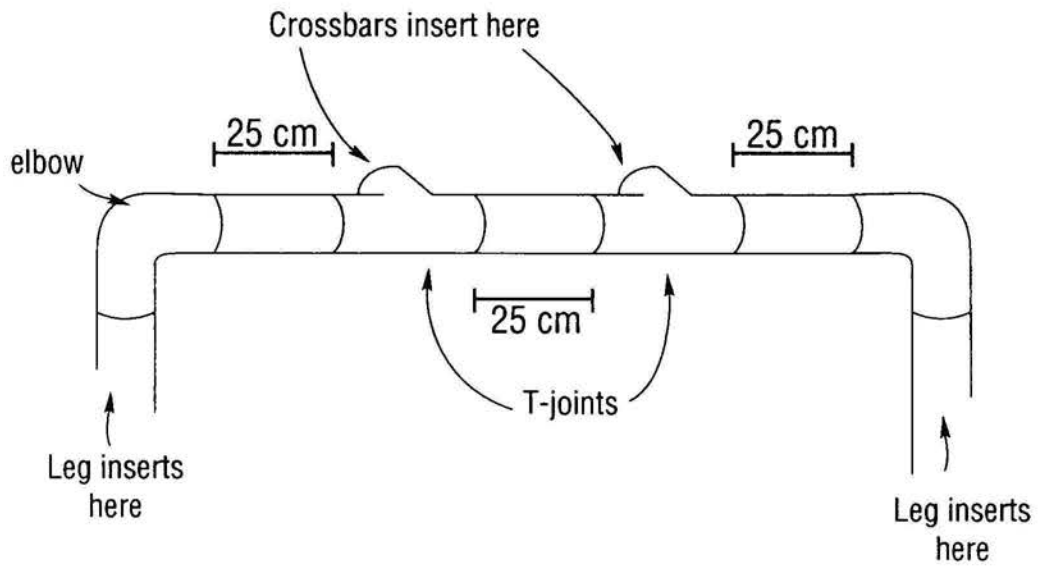

**Figure A.**

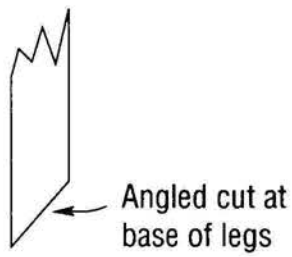

**Figure B.**

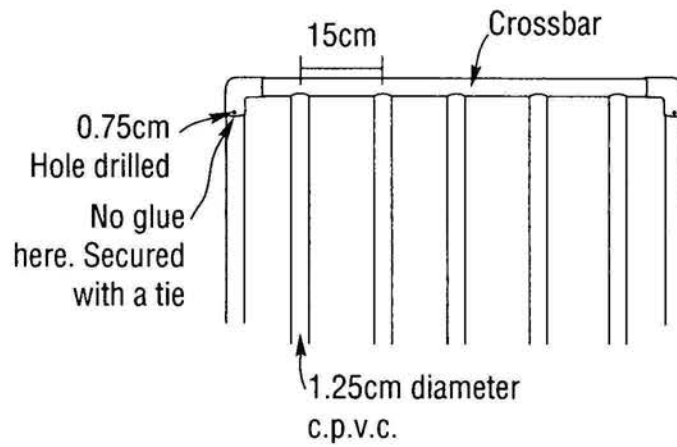

**Figure C.**