

The University of Georgia  
College of Agricultural and Environmental Sciences  
Cooperative Extension

ANIMAL WASTE ANALYSIS

(For Fertilizer Use)

A representative sample of the material should be submitted as close as possible to the time of application. Samples should be shipped in pint-size freezer bags or plastic bottles. **Do not staple forms to freezer bag. Glass containers are not acceptable** because they may break in shipment; also, enclosed Animal Waste Submission form.

Poultry Litter Analysis: Since April 2000, the Total Minerals Test (A-1) has been provided free of charge to Georgia Poultry Procedures who submit poultry litter through their county extension program. Litter testing is an integral part of the Georgia Poultry industry program of voluntary comprehensive nutrient management plans (CN<P's) that call for both soil and litter/manure testing. Funds have been appropriated by the Georgia General Assembly to support the free litter-testing program. **Only the A-1 test is free**; charges still apply for other tests on poultry litter.

**In order to participate in the "Free" litter test, it is required** that the correct submission form and all of the information on that form be submitted with each sample. The information on the form will serve as a valuable contribution to our ongoing database for long-term nutrient management planning.

### Manure Testing

Manures can be quite variable in nutrient content. This variability may be due to different animal species, feed composition, bedding materials, storage and handling as well as other factors. Testing at or near the time of application tells you the fertilizer value to make decisions about rates to apply. Some livestock producers are faced with nutrient management regulations that require manure testing, also, if buying or selling litter/manure for fertilizer use, testing will help both buyer and seller establish the fertilizer value.

#### Manure Sample Collection

According to the Georgia Environmental Protection Division (EPD) "Swine Feeding Operation Permit Requirements," lagoon effluent is to be sampled semiannually. Preferably, the sample should be taken as near the application time as possible prior to the manure application. However, if it is urgent to pump down a full lagoon or storage pond, you should not wait until you can sample and obtain the results. You should sample the day of irrigation. The results can later be used to determine the nutrients applied to the fields and identify the need for additional nutrients to complete crop production.

Manures should be sampled and tested near the time of application because the nutrient content can change considerably over time, particularly if stockpiled and unprotected from the weather. Nitrogen (N) is the nutrient that is the most likely to be affected. The frequency for testing your manure will depend upon several factors, but as noted above, lagoon effluent needs to be tested at least semiannually. The type of manure and overall management system will also be factors. Animal producers using lagoon manure storage systems should sample every time that the liquid or slurry will be pumped and applied to the land. Proper sampling is the key to reliable manure analysis. Although laboratory procedures are accurate, they have little value if the sample fails to represent the manure product. Manure samples submitted to a laboratory should represent the average composition of the material that will be applied to the field. Reliable samples typically consist of material collected from a number of locations. Precise sampling methods vary according to the type of manure.

### Liquid Manure

Liquid manure samples submitted for analysis should meet the following requirements:

- Place sample in a sealed, clean plastic container with about a 1-pint volume. Glass is not suitable because it is breakable and may contain contaminants.
- Leave at least 1 inch of air space in the plastic container to allow for expansion caused by the release of gas from the manure material.
- Refrigerate or freeze samples that cannot be shipped on the day they are collected. This will minimize chemical reactions and pressure buildup from gases.

Ideally, liquid manure should be sampled after it is thoroughly mixed. Because this is sometimes impractical, samples can also be taken in accordance with the suggestions that follow:

*Lagoon effluent.* Premixing the surface liquid in the lagoon is not needed, provided it is the only component that is being pumped. Growers with multistage systems should draw samples from the lagoon they intend to pump for crop irrigation.

Samples should be collected using a clean, plastic container similar to the one shown in Figure 1. One pint of materials should be taken from at least eight sites around the lagoon and then mixed in the larger, clean, plastic container. Effluent should be collected at least 6 feet from the edge of the lagoon at a depth of about a foot. Shallower samples from anaerobic lagoons may be less representative than deep samples because oxygen transfer near the surface sometimes alters the chemistry of the solution. Floating debris and scum should be avoided. One pint of the mixed material should be sent to the laboratory. Galvanized containers should never be used for collection, mixing, or storage due to the risk of contamination from metals like zinc in the container.

*Liquid slurry.* Manure slurries that are applied from a pit or storage pond should be mixed prior to sampling. If you agitate your pit or basin prior to sampling, a sampling device pictured in Figure 1 can be used. If you wish to sample a storage structure without agitation, you must use a composite sampling device as shown in Figure 2. Manure should be collected from approximately eight areas around the pit or pond and mixed thoroughly in a clean, plastic container. An 8 to 10 foot section of 0.5-0.75 inch plastic pipe can also be used; extend the pipe into the pit with ball plug open, pull up the ball plug (or press your thumb over the end to form an air lock), and remove the pipe from the manure, releasing the air lock to deposit the manure into the plastic container.

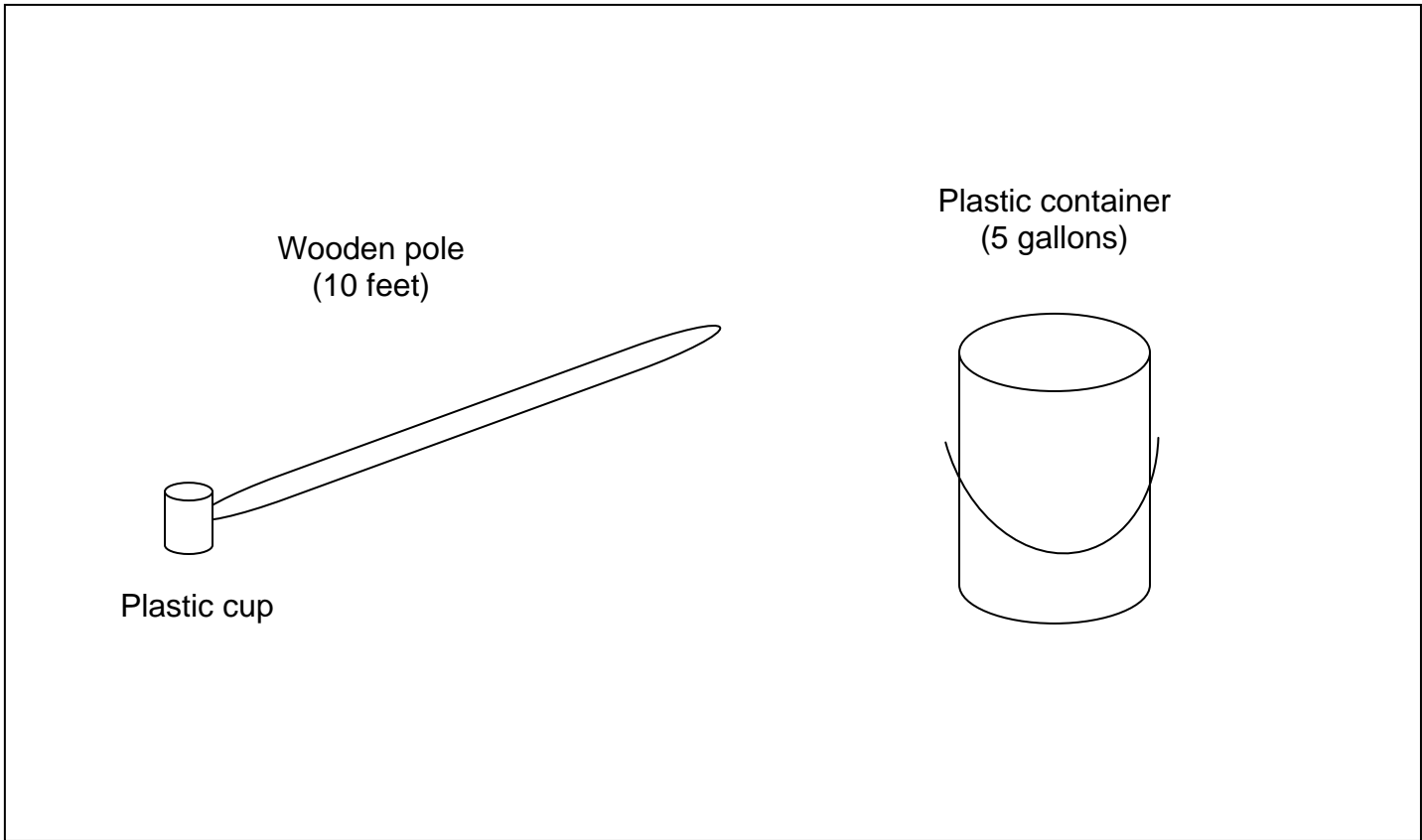

Figure 1. Liquid manure sampling device

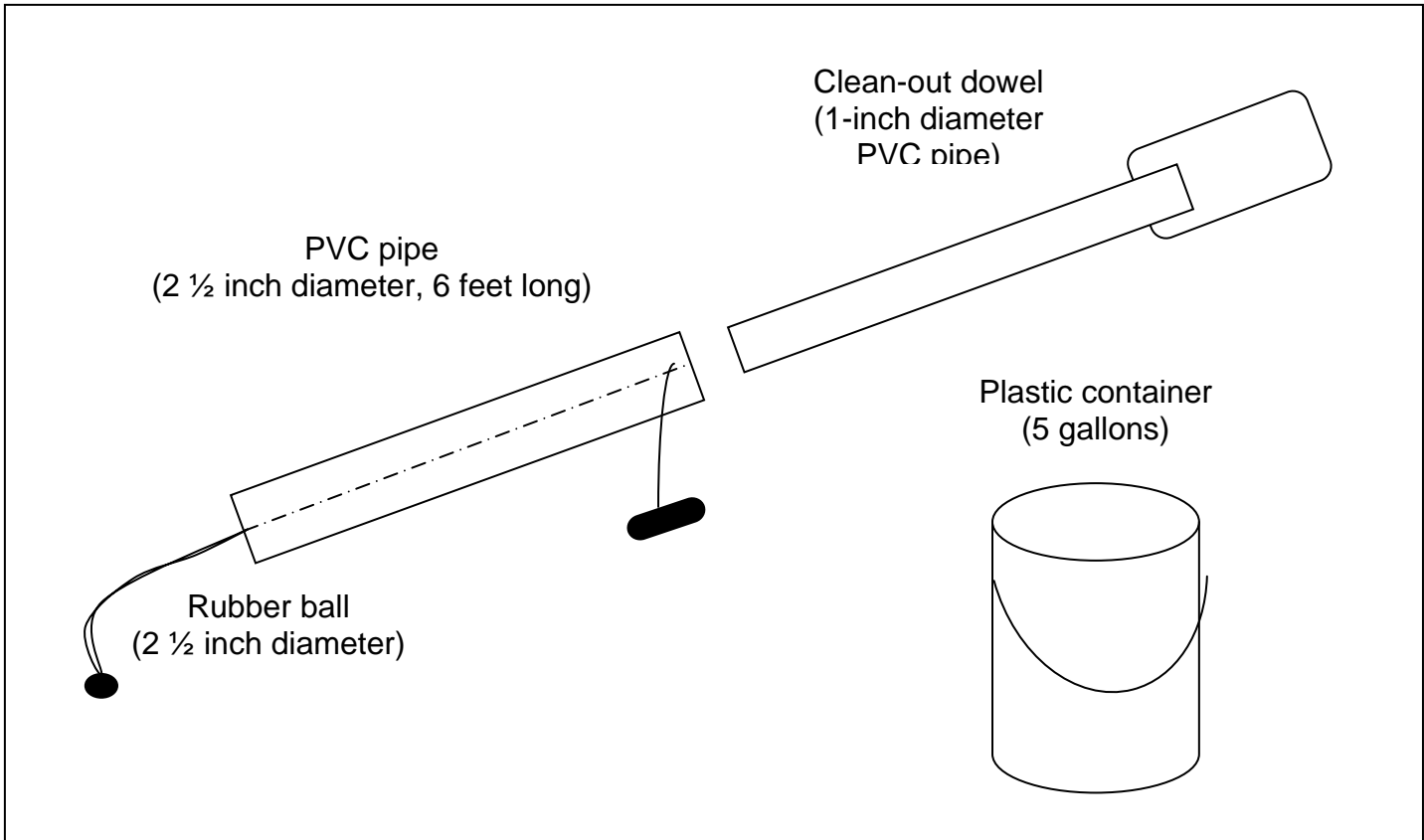

Figure 2. Composite sampling device

Lagoon sludge: Representative samples of lagoon sludge are more difficult to obtain than samples with lower solid contents. Two common methods are used. One method requires lagoon pump-down to the sludge layers. Then, during sludge agitation, a liquid or slurry type of sample described above may be collected. The other method requires insertion of a probe into the lagoon to the bottom to obtain a column of material. A “sludge-judge” is a device commonly used for this type of sampling. The sludge component of this column is then released into a clean plastic bucket, and several (12-20) other sampling points around the lagoon are likewise collected to obtain a composite, representative sample. This procedure must be performed with a boat or mobile floating dock.

For analysis, most laboratories require at least 1 pint of material in a plastic container. The sample should not be rinsed into the container because doing so dilutes the mixture and distorts nutrient evaluations. However, if water is typically added to the manure prior to land application, a proportionate quantity of water should be added to the sample.

Solid Manure

Solid manure samples should represent the average moisture content of the manure. A one-quart sample is adequate for analysis. Samples should be taken from approximately eight different areas in the manure pile, placed in a clean, plastic container, and thoroughly mixed. Approximately one quart of the mixed sample should be placed in a plastic bag, sealed and shipped directory to the laboratory. Samples stored for more than two days should be refrigerated. Figure 3 shows a device for sampling solid manure.

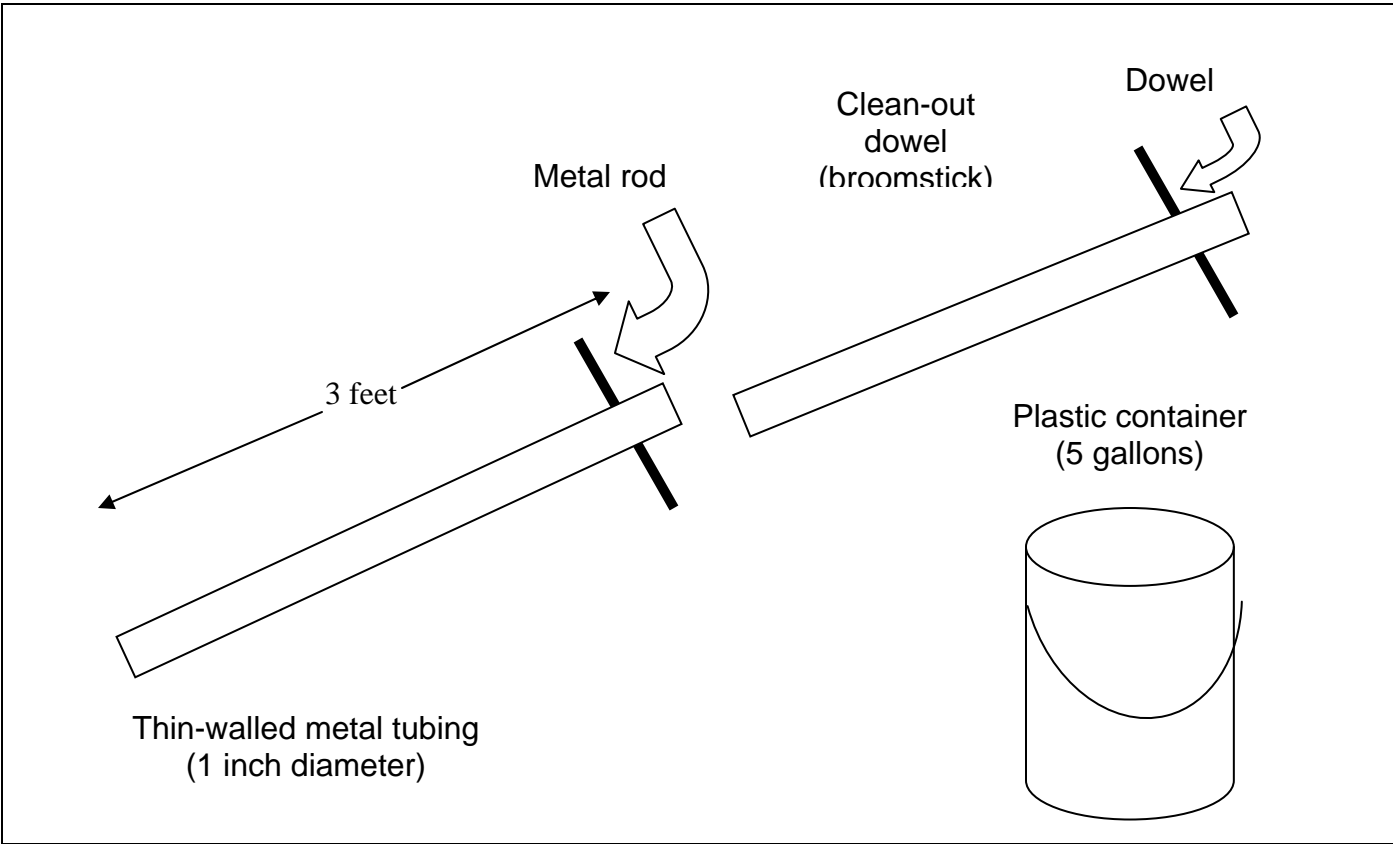

Figure 3. Solid manure sampling device

Stockpiled manure or litter: Ideally, stockpiled manure and litter should be stored under cover on an impervious surface. The weathered exterior of uncovered waste may not accurately represent the majority of the material. Rainfall generally moves water-soluble nutrients down into the pile. If an unprotected stockpile is used over an extended period, it should be sampled before each application.

Stockpiled manure should be sampled at a depth of at least 18 inches at six or more locations. The collected material should be combined in a plastic container and mixed thoroughly. The one-quart laboratory sample should be taken from this mixture, placed in a plastic bag, sealed, and shipped to the laboratory for analysis. If the sample cannot be shipped within one day of sampling, it should be refrigerated.